



Preetha and Adrit's grandmother made a quilt cover using old clothes. Now she wants to decorate it with lace. Tick the lace option that would cover the entire border of the quilt.



(i) Red lace
40 units



(ii) Green lace
50 units

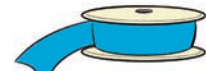

(iii) Blue lace
25 units

She decides to use two different coloured laces. How much lace of each kind will be needed to cover the entire border?

Recall that the length of the border of a shape is called its **perimeter**.

Let Us Do

- Find the perimeter of the following shapes. All sides of the following shapes are equal.

4 cm

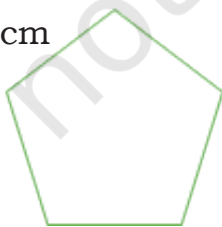

5 cm



- Draw two rectangles each having the following perimeters.

(a) 26 cm

(b) 18 cm

Preetha and Adrit's grandmother is making a rug with square patches. The picture below shows the rug. How many patches have they used to make this?

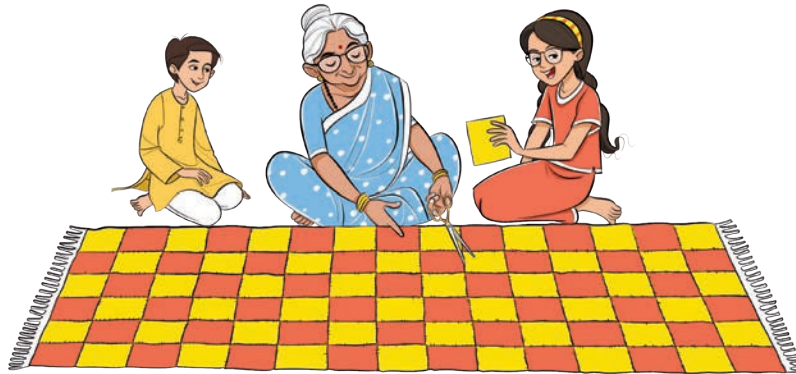

Preetha and Adrit are trying to cover their table with different shapes. Preetha covered it with triangles and circles. Adrit covered with squares and rectangles.

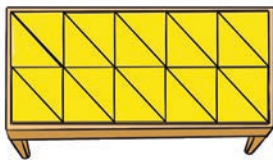

Table 1

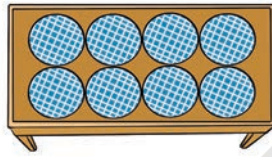

Table 2

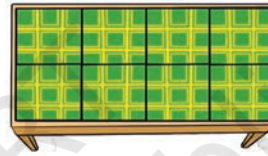

Table 3

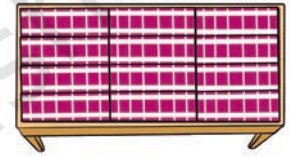

Table 4

They found that _____, _____ and _____ shapes cover the top of the table without gaps and overlaps. _____ shape leaves gaps.

_____ triangles cover Table 1.

_____ squares cover Table 3.

_____ rectangles cover Table 4.

The region covered by the triangles, squares or rectangles is called the **area** of the table.

To find the area of a region, we usually fill it with shapes that tile (no gaps and overlaps), like squares, rectangles and triangles.

Do circles tile? Can we use them to cover a region?

The area of Table 1 is _____ triangle units.

The area of Table 3 is _____ square units.

The area of Table 4 is _____ rectangle units.

Now, try to cover the top of your table without gaps and overlaps with the following objects of same size.

(a) Notebooks

(b) Lunch boxes

(c) Pencil boxes

(d) Maths textbooks

Which of the above objects covered the region completely?

Let Us Do

Preetha is playing with tiles. She covers her desk with different shapes as shown below.

Look at the different tiles on her desk and answer how many of the following shapes will cover the desk.

- (a) Green triangles _____
- (b) Red triangles _____
- (c) Blue squares _____

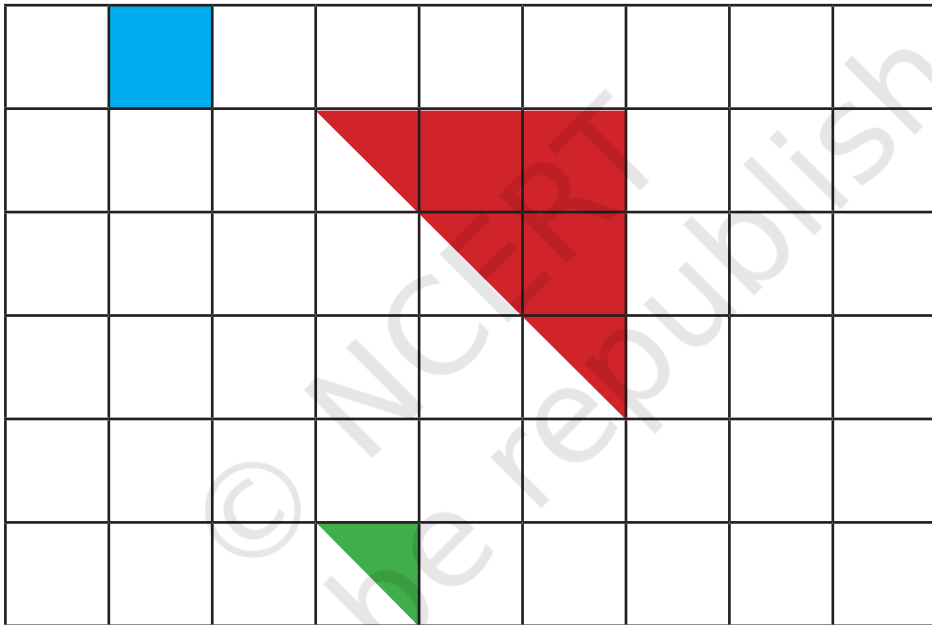

Comparing Shapes

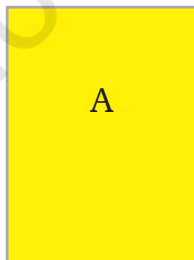

Which of the above rectangles has the largest area? Trace these shapes on to a paper and cut them to find out the one that has the largest area.

Do you see that the area of rectangle A is larger than that of B? What about B and C?

Which shape has a larger area among A and C? How will you find out?

Let us put these rectangles on a square grid. Now, can you identify the rectangle that has the largest area?

Using square grids is the most convenient way to find the area of regions. We say that the area of a square with sides 1 unit is 1 unit square.

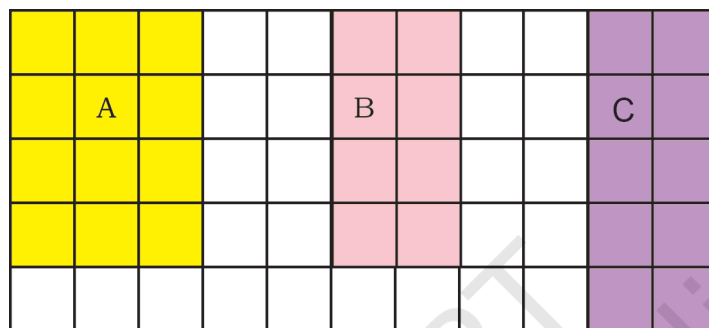

1 unit

Area = 1 unit square



Let Us Do

- Compare the areas of the two gardens given below on the square grid. Share your observations.

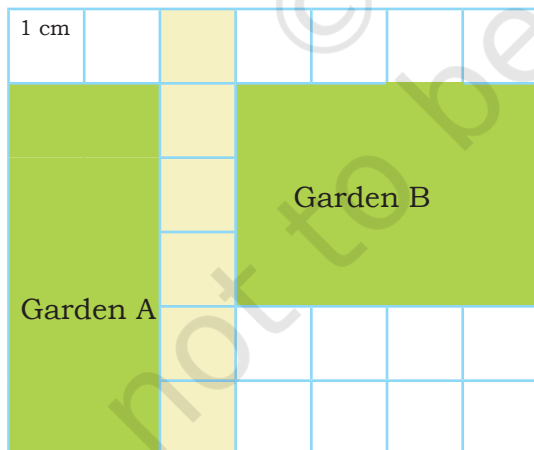

Area of Garden A = _____ cm square

Area of Garden B = _____ cm square

Note for Teachers: Tiles of several shapes like triangles, rectangles, and squares can be used to measure the area of a region. We choose a square as a unit for measuring area as its sides are of equal length. Therefore, we can define the area of a unit square as 1 unit square. This allows us to measure area, similar to that of measuring length.

2. Trace your palm on the square grid given below and find the approximate area of your palm. Compare the area of your palm with your friend's palm. Who has a bigger palm?

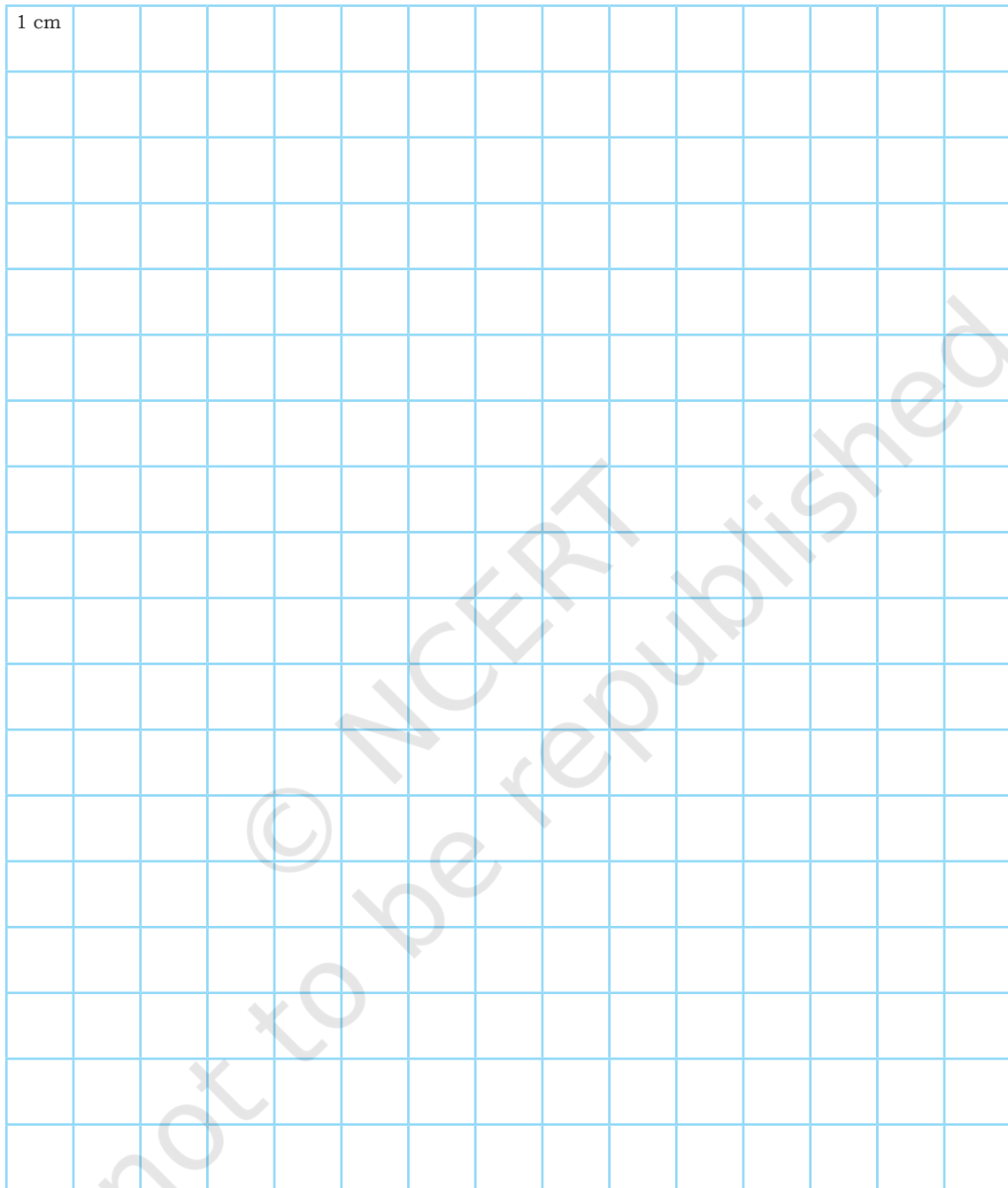

3. Collect leaves of different kinds. Put them on a square grid and find their area.
- (a) Name the leaf with the largest area.
 - (b) Name the leaf with the smallest area.

4. The following mats are made of square patches of equal size. How many square patches will be required to cover each mat? Would both mats require an equal or different number of patches? Trace and cut out a small square of the size give below and find the area.

(a)



Area = _____

Perimeter = _____

(b)

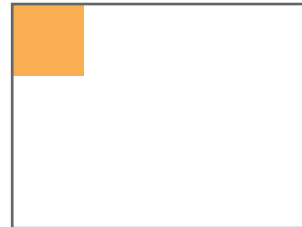

Area = _____

Perimeter = _____

Trisha makes these two rectangles. She says, “I increased the area of my rectangle, and the perimeter increased.” Do you think this is always true?

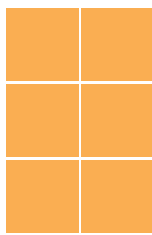

Let Us Explore

1. Tick the shapes with the same area. Find the perimeters of these shapes. What do you notice? Discuss.

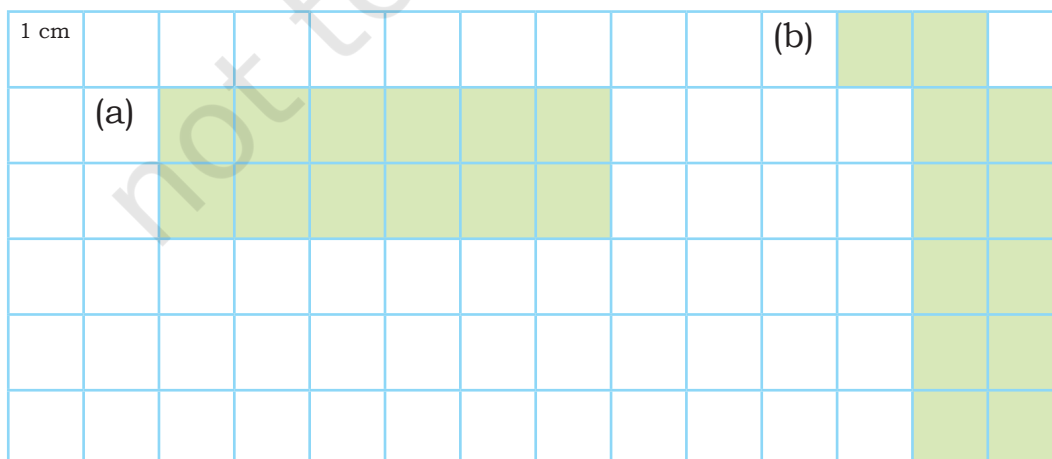

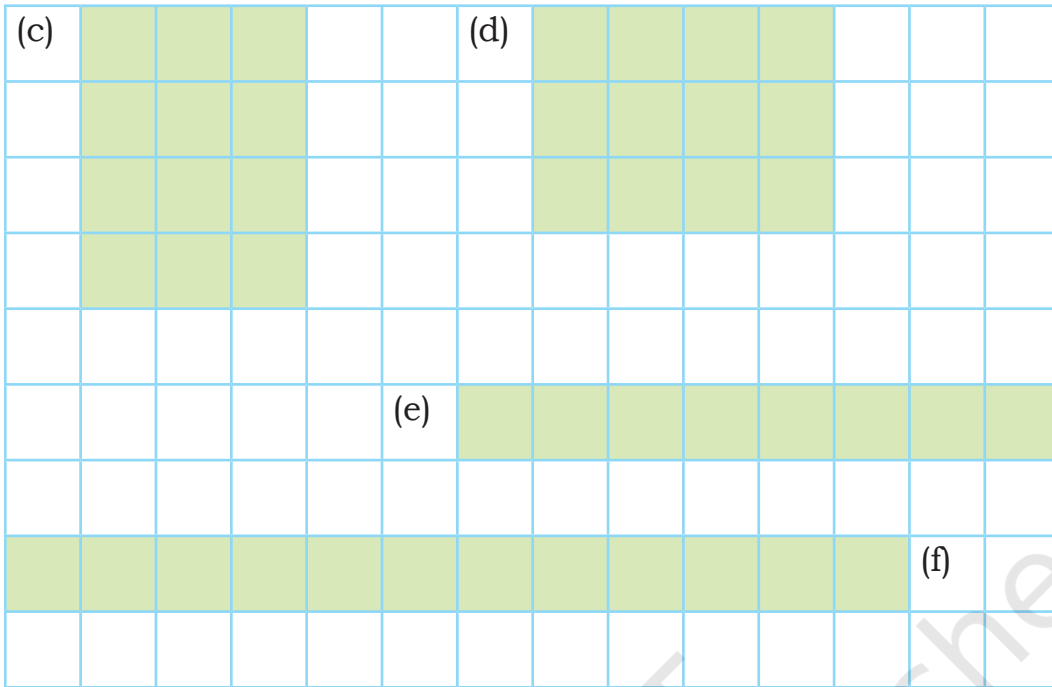

2. Tick the shapes with the same perimeter. Find the areas of these shapes. What do you notice? Discuss.

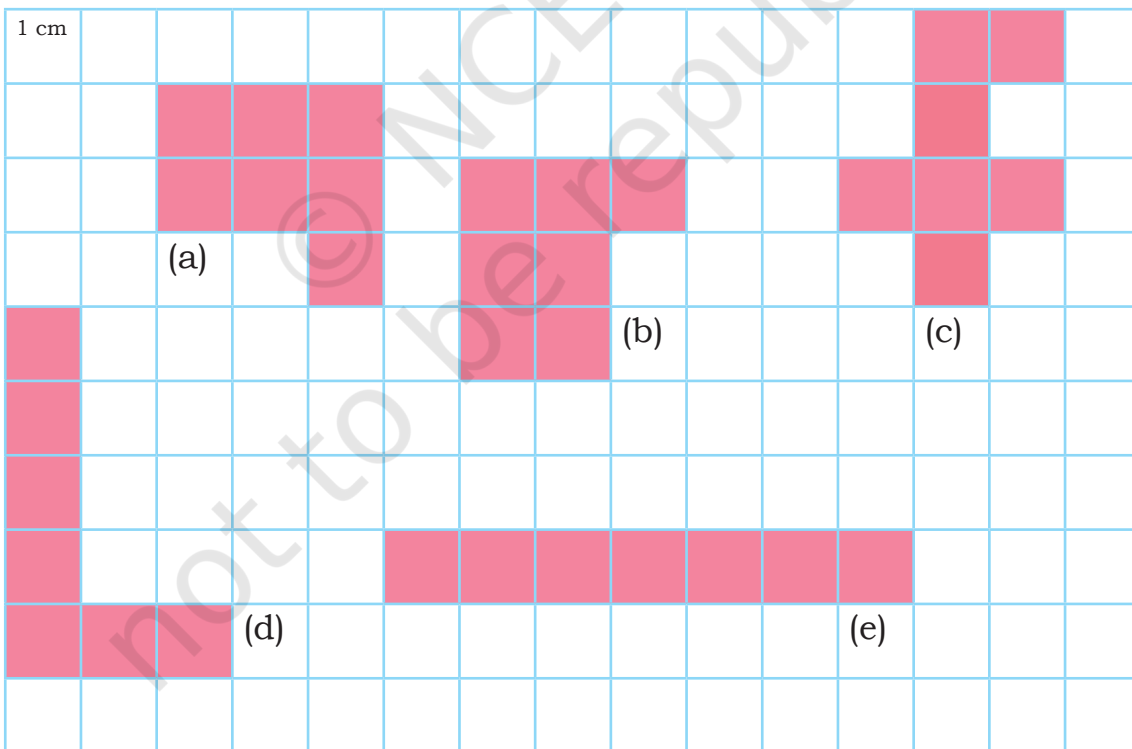

Let Us Do

1. Draw different shapes having the same area as the given shape. Write the perimeter of each shape. What do you notice? Discuss.

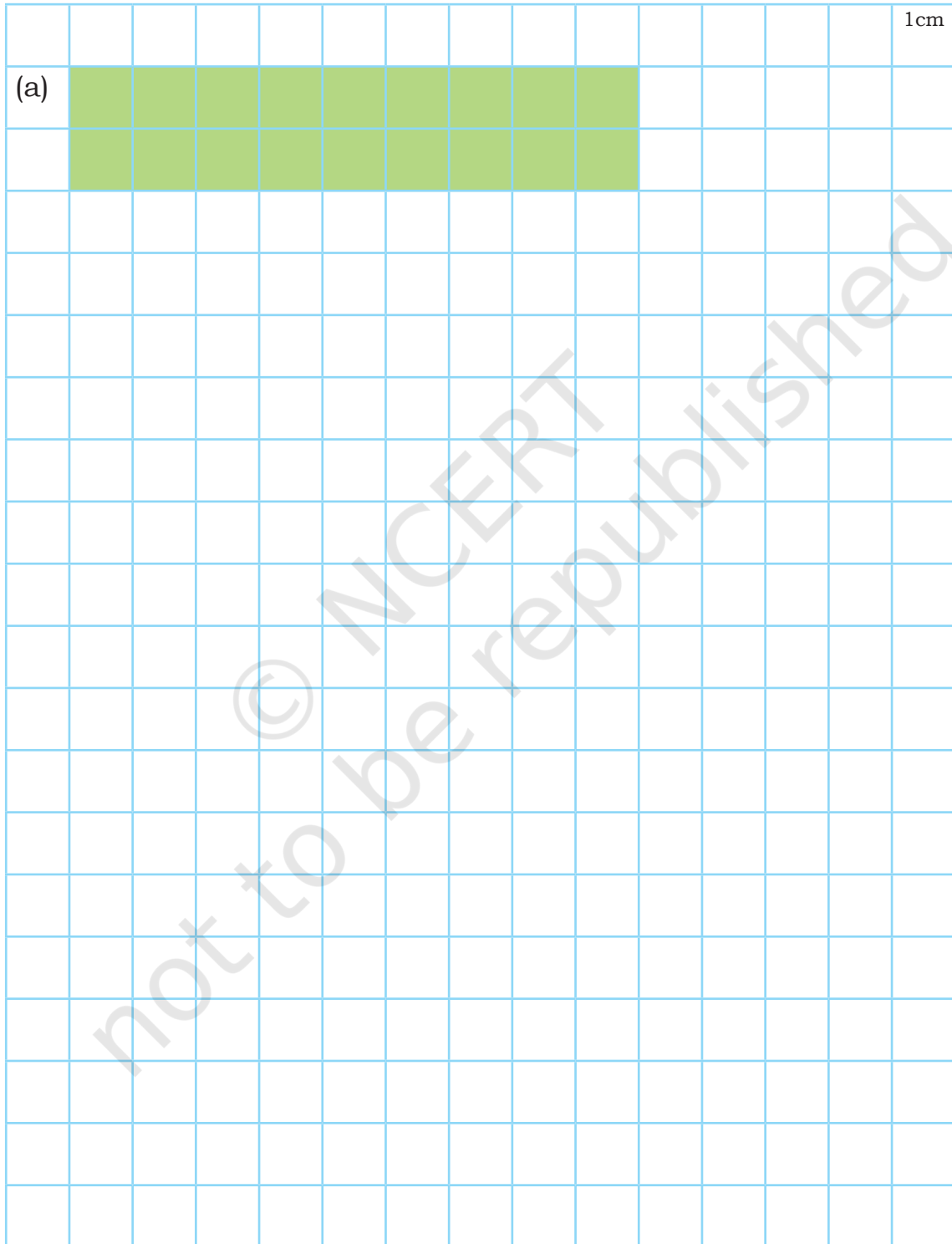

2. Is the area of shape (a) less than the area of shape (b) given below? Discuss.

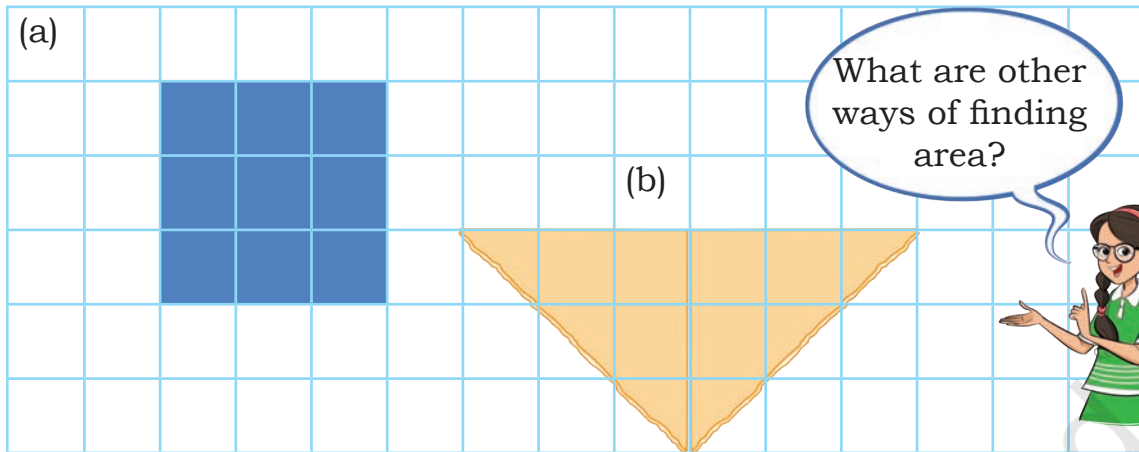

Preetha and Adrit's grandmother is making another square patchwork. She arranges the patches as shown below. Can you guess how many patches she will need? How did you find it?

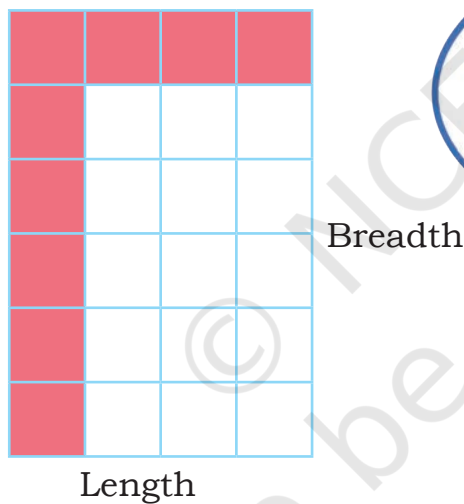

We don't need to count them all. Look! There are 6 rows of 4 patches each. That is $6 \times 4 = 24$ patches.



Did you notice that 6 is the length of one side and 4 is the length of the non-equal side of the rectangle?

Go back to the previous examples and check whether the product of the length and the breadth of the rectangles is the same as the area you had calculated by counting.

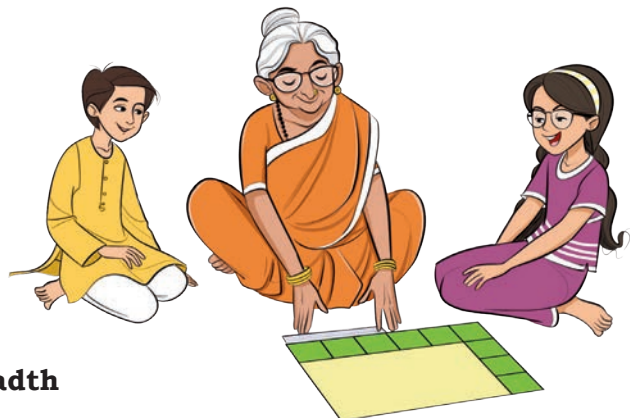

Area of Rectangle = **Length** × **Breadth**
 Area of square patch work = 6 cm × 4 cm
 = 24 square cm

Similarly, we can also find the perimeter of the rectangular shape.

$$\begin{aligned}\text{Perimeter} &= \text{Length} + \text{Length} + \text{Breadth} + \text{Breadth} \\ &= 2 \times \text{Length} + 2 \times \text{Breadth}\end{aligned}$$

The lengths of the opposite sides of a rectangle are equal.



What will happen if all the sides of a rectangle are equal, that is, the case of square?



Let us think about a square whose sides are 5 units long.

$$\begin{aligned}\text{Area of Square} &= \text{Length} \times \text{Length} \\ \text{Area} &= 5 \times 5 \\ &= 25 \text{ square cm} \\ \text{Perimeter of Square} &= \text{Length} + \text{Length} + \text{Length} + \text{Length} \\ &= 4 \times \text{Length} \\ &= 4 \times 5 \\ &= 20 \text{ cm}\end{aligned}$$

Let Us Do

1. Find the area of your classroom floor in square meters. Take the help of your teacher to measure the length and breadth of the floor. What is the perimeter of the classroom floor?

Note for Teachers: Instead of counting each square, see that rectangles can be tiled by a row-column arrangement of unit squares. To find the area, they can simply multiply the number of rows by numbers of columns. This will also build an understanding of area as a model for multiplication.

2. Find the area and perimeter of the following shapes.

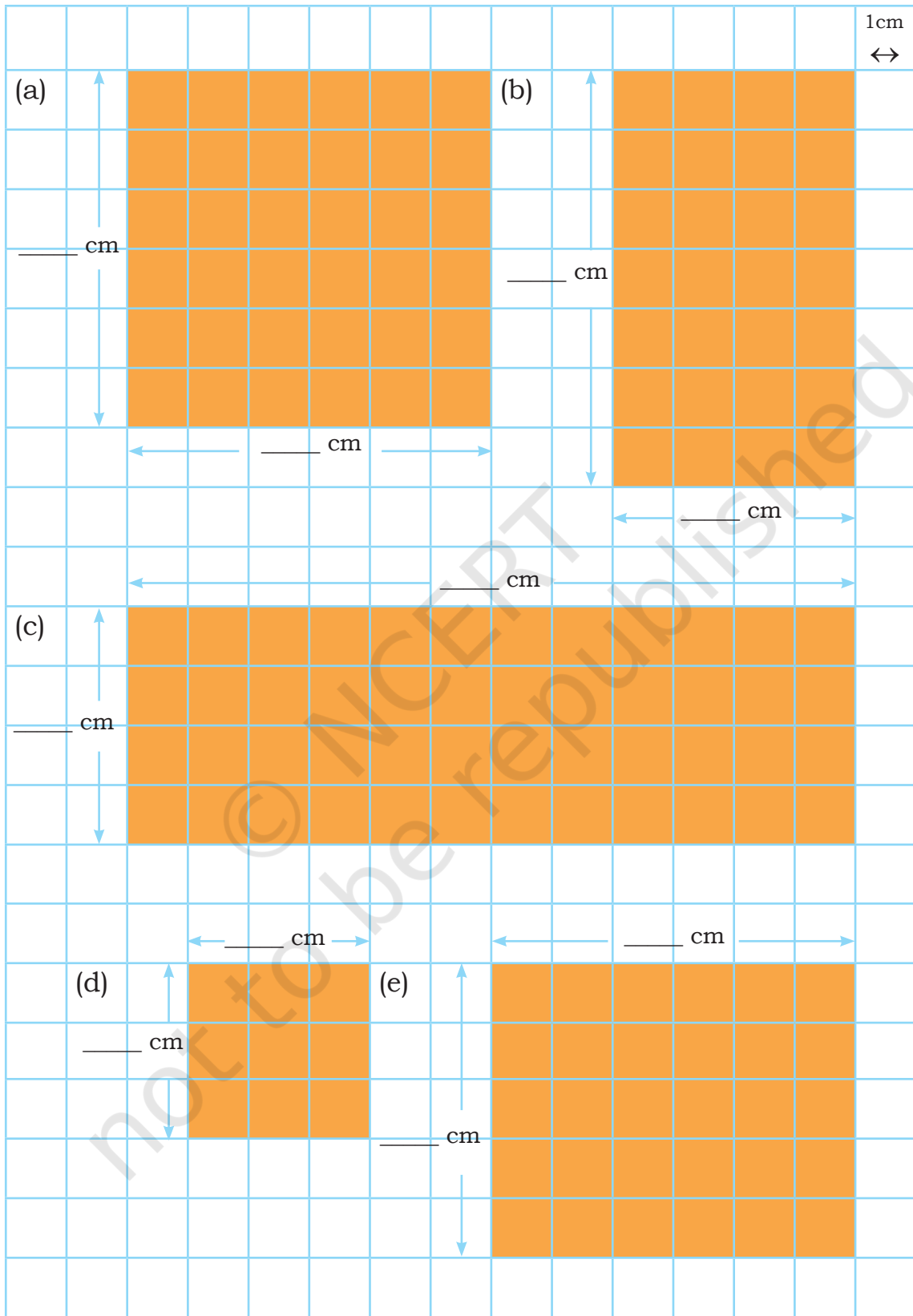

3. Find the area and perimeter of the following objects. Use a scale or measuring tape to find the length and the breadth of each of the objects.

S. No.	Name of the objects	Area	Perimeter
1.	Cover of the Notebook		
2.	Newspaper		
3.	Blackboard		
4.	Ludo board		
5.			
6.			

4. Find the area of a rectangular field whose length is 42 m and breadth is 34 m.
5. The area of a rectangular garden is 64 square m and its length is 16 m. What is its breadth?
6. Find the area of the following figure with the dimensions as marked in the figure.

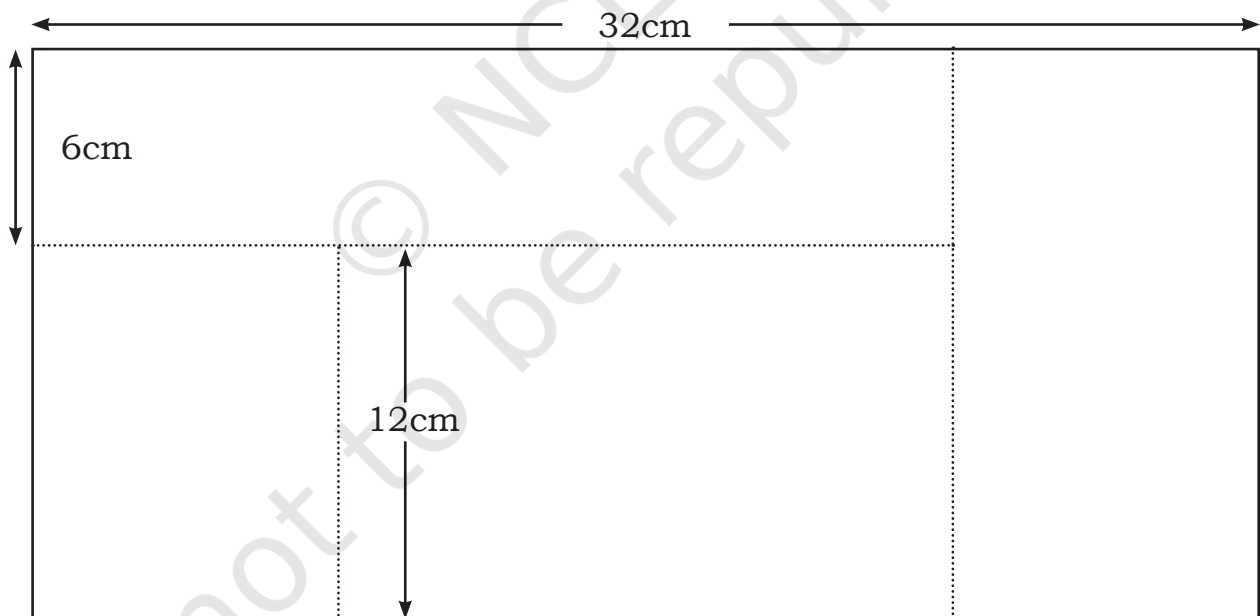

Let Us Play

1. Take some square tiles and a die and play the game in pairs.

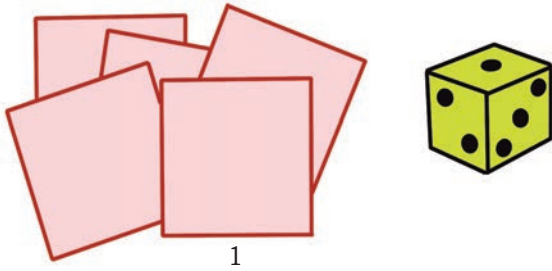

2. Roll the die and pick the number of tiles equal to the dots on the die. Arrange them to make a shape or figure.

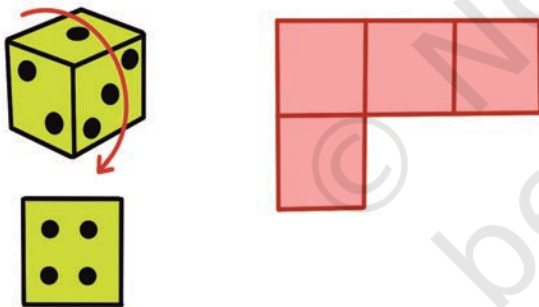

3. Find the perimeter of the tiles.

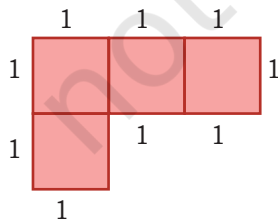

=10

4. Do not move the tiles. The second player can take turn and add tiles to the same tiled figure.

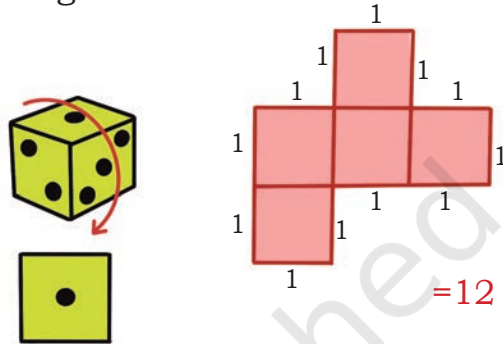

=12

5. Take turns and add tiles to the same figure till the perimeter becomes 24.

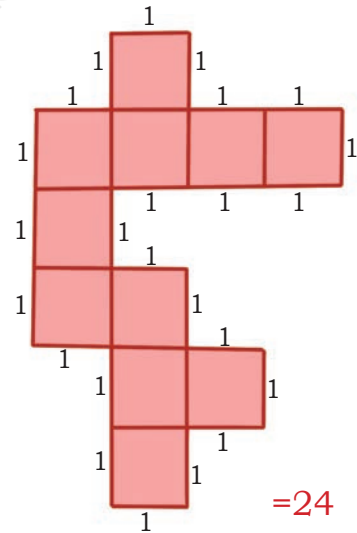

=24

The one who makes the perimeter 24 wins the game.

