

EXTRA RESOURCES BASED ON LEARNING OUTCOMES AT UPPER PRIMARY STAGE

WORKBOOK CLASS - VII

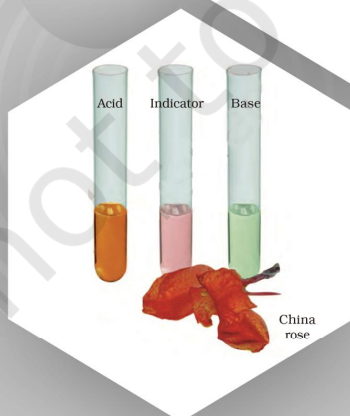
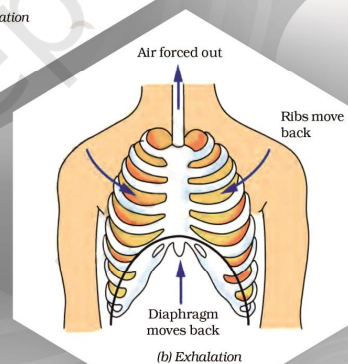
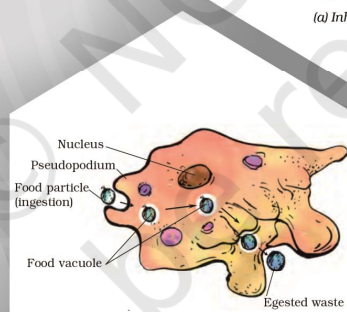
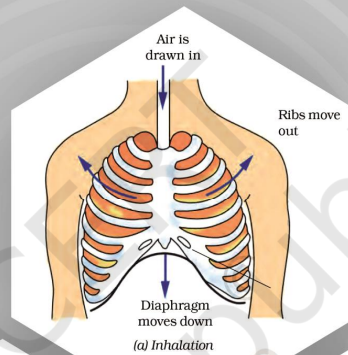

PREFACE

The literature on 'Education for All' (EFA), in the last three decades emphasized on quality of education. It has been considered in terms of enrolment, retention and achievement. It further included desirable characteristics of learners, learning processes, facilities, learning materials, contents, governance and management and learning outcomes.

As per the recent Global Monitoring Report (GMR)–2015, impressive gains in access to education have occurred in developing countries including India, but improvement in quality still remains a concern. In India, different achievement surveys such as the Annual Status of Education Report (ASER) reported wide disparities in students' achievement of basic skills across states, which were also affirmed by the National Achievement Survey (NAS) of Class III, (MHRD, 2014).

Most often, teachers are not clear about what kind of learning is desired and the criteria against which it could be assessed. They use textbooks as the complete curriculum and assess children using questions given at the unit end exercises. The contextual variations in textual material and variations in pedagogy adopted are generally not taken into account, for there are no criteria to assess them. The learning outcomes for each class not only help the teachers to direct their teaching-learning in the desired manner but make other stakeholders, especially the parents or guardians, School Management Committee (SMC) members, community and the state functionaries to be responsible and alert towards their role for ensuring quality education. The learning outcomes defined explicitly can guide and ensure the responsibility and accountability of different stakeholders for its accomplishment by expectations in different curricular areas.

In the view of learning continuum, NCERT developed a document which includes learning outcomes in all the curricular areas at the elementary stage, linked to curriculum expectations and the pedagogical processes. Based on the respective document, to assess the understanding of the students of the content, several worksheets have been assembled in a form of a workbook. It will help the teachers as well as parents to analyze the cognitive ability of the student.

The National Council of Educational Research and Training (NCERT) appreciate the hard work done by the Textbook Development Committee responsible for this workbook. Several teachers contributed to the development of this workbook; we are grateful to them for making this possible.

As an organization committed to systemic reform and continuous improvement in the quality of its products, NCERT welcomes comments and suggestions which will enable us to undertake further revision and refinement.

DEVELOPMENT TEAM MEMBERS

MEMBER- COORDINATOR

Pramila Tanwar, Associate Professor, DESM, NCERT, New Delhi

DEVELOPMENT TEAM, NCERT

Anjni Koul, Professor, DESM, NCERT, New Delhi

Ashish Kr. Srivastava, Assistant Professor, DESM, NCERT, New Delhi

C.V. Shimray, Associate Professor, DESM, NCERT, New Delhi

Dinesh Kumar, Professor, DESM, NCERT, New Delhi

Gagan Gupta, Associate Professor, DESM, NCERT, New Delhi

K.V. Sri Devi, Assistant Professor, DCS, NCERT, New Delhi

Poonam Aggarwal, Professor, DGS, NCERT, New Delhi

Pushplata Verma, Associate Professor, DESM, NCERT, New Delhi

R. K. Parashar, Professor, DESM, NCERT, New Delhi

Rachna Garg, Professor, DESM, NCERT, New Delhi

Ruchi Verma, Professor, DESM, NCERT, New Delhi

R. K. Sharma, Assistant Professor, DESM, RIE Ajmer

Sharad Sinha, Professor, DTE, NCERT, New Delhi

S.C. Chauhan, Professor & Head, DEGSN, NCERT, New Delhi

Sunita Farkya, Professor & Head, DESM, NCERT, New Delhi

Veerpal Singh, Professor & Head, ESD, NCERT, New Delhi

Vinay Kumar Singh, Professor, DEGSN, NCERT, New Delhi

V. P. Arya, Assistant Professor, DESM, RIE Ajmer

SUPPORTING STAFF

Academic

Romeo Khonganbatbam, Junior Project Fellow, DESM, NCERT

Shiksha Tiwari, Junior Project Fellow, DESM, NCERT

Non-Academic

Ankit Sharma, Computer Typist, DESM, NCERT

Arun Verma, DTP Operator, DESM, NCERT

Manju Negi, Computer Typist, DESM, NCERT

Rajiv Chandeliya, DTP Operator, DESM, NCERT

Acknowledgements

The National Council of Educational Research and Training (NCERT) acknowledge the valuable contribution of the individuals and organizations involved in the development of Science Workbook for Class VI. The Council acknowledges the valuable contribution of the following academics for the development of the worksheets of this book: Dr.Ravijot Sandhu, *lecturer*, NDMC- Navyug School, Peshwa Road, New Delhi; Ms.Preeti Khanna, *Senior TGT*, National Blind Association, Delhi; Dr.Abinash Kumar Singh, *PGT*, K.V. BSF Camp, Chhawla, New Delhi; Ms.Reema Marwah, *TGT*, The Mothers International School, New Delhi; Ms. Swati Bhardwaj, *TGT*, The Mothers International School, New Delhi. We are thankful to them.

The dynamic leadership of Professor Sunita Farkya, Head, DESM, for providing guidance and continuous support in extending infrastructure facilities is highly acknowledged.

The Council also acknowledges the efforts of Romeo Khonganbatbam, Junior Project Fellow, ShikshaTiwari, Junior Project Fellow, Ankit Sharma, Computer Typist, ArunVerma, DTP Operator, ManjuNegi, Computer Typist, Rajiv Chandeliya, Graphic Designer, DESM, and NCERT.

The Contribution of APC-office, administration of DESM, Publication Department and Secretariat of NCERT is also acknowledgement.

TABLE OF CONTENTS

S. No.	Learning Outcome	Worksheet No.	Page No.
1	Identifies materials and organisms, such as, animal fibres; types of teeth; mirrors and lenses on the basis of observable features, i.e., appearance, texture, functions, etc.	1	1-2
		2	3-4
		3	5
		4	6-7
		5	8
		6	9
		7	10
		8	11
		9	12-13
		10	14
		11	15
		12	16
		13	17
		14	18
2	Differentiates materials and organisms such as, digestion in different organisms; unisexual and bisexual flowers; conductors and insulators of heat; acidic, basic and neutral substances; images formed by mirrors and lenses, etc., on the basis of their properties, structure and function.	15	19-20
		16	21-22
3	Classifies materials and organisms based on properties/ characteristics, e.g., plant and animal fibres; physical and chemical changes	17	23
		18	24-25
		19	26
		20	27
		21	28

		22	29
		23	30
4	Conducts simple investigations to seek answers to queries, e.g., can extract of coloured flowers be used as acid-base indicator? Do leaves other than green also carry out photosynthesis? Is white light composed of many colours?	24	31-32
		25	33
		26	34-35
		27	36-37
		28	38-39
		29	40-42
		30	43
5	Relates processes and phenomena with causes, e.g., wind speed with air pressure; crops grown with types of soil; depletion of water table with human activities, etc.	31	44-45
		32	46-47
		33	48-49
		34	50-51
		35	52-53
		36	54-55
6	Explains processes and phenomena with causes, e.g., wind speed with air pressure; crops grown with types of soil; depletion of water table with human activities, etc.	37	56-58
7	Writes word equation for chemical reactions, e.g., acid-base reactions; corrosion; photosynthesis; respiration, etc.	38	59-60
		39	61
		40	62
		41	63-64
		42	65
		43	66
		44	67
8	Measures and calculates e.g., temperature; pulse	45	68-69

	rate; speed of moving objects; time periods of a simple pendulum, etc.		
		46	70-71
		47	72-73
		48	74
		49	75-76
		50	77-78
9	Draws labelled diagrams/ flow charts e.g., organ systems in humans and plants; electric circuits; experimental set ups; life cycle of silk moth, etc.	51	79-80
		52	81
		53	82
		54	83
		55	84
		56	85-86
		57	87
		58	88
		59	89-91
		60	92-94
10	Plots and interprets graphs e.g. distance time graph.	61	95-96
		62	97
		63	98
		64	99-100
		65	101-104
11	Constructs models using materials from surroundings and explains their working, e.g., stethoscope; anemometer; electromagnets; Newton's colour disc, etc.	66	105-106
		67	107
		68	108
12	Discusses and appreciates stories of scientific discoveries.	69	109-110

		70	111
13	Applies learning of scientific concepts in day to day life, e.g., dealing with acidity; testing and treating soil; taking measures to prevent corrosion; cultivation by vegetative propagation; connecting two or more electric cells in proper order in devices; taking measures during and after disasters; suggesting methods for treatment of polluted water for reuse etc.	71	112
		72	113-115
14	Makes efforts to protect environment, e.g., following good practices for sanitation at public places; minimising generation of pollutants; planting trees to avoid soil erosion; sensitising others with the consequences of excessive consumption of natural resources, etc.	73	116
15	Exhibits creativity in designing, planning, making use of available resources etc.	74	117
16	Exhibits values of honesty, objectivity, cooperation, freedom from fear and prejudices.	75	118

Worksheet: 1 (Mode: Face to Face) (LO-1)

Learning Outcomes to be achieved:

Identifies materials and organisms, such as, animal fibres; types of teeth; mirrors and lenses on the basis of observable features, i.e., appearance, texture, functions, etc.

Q1. Ram was not taking proper care of his teeth. He was suffering from toothache. His father took him to the dentist for the treatment. Dentist used a spherical mirror to view his teeth as shown below



(I). Identify the type of mirror used by the dentist.
.....
.....

(II). Why can't doctor use plane mirror instead of this type of spherical mirror?
.....
.....

(III). Can you give any other practical application of this type of a mirror?
.....
.....

Q2. Jyoti had two types of spherical mirrors. When she viewed herself in those mirrors, in one case (mirror A) the image formed was erect and diminished even if she moved away from the mirror. When she stood in front of the second mirror (mirror B) the image was erect and magnified but when she moved away from the mirror her image became inverted.

(I). Identify:
Mirror A.....

Mirror B.....

(II). Can you identify the type of spherical mirrors (A and B) only by touching them and not looking at the image formed by them. If yes, how?

.....
.....
.....
.....

Q3. Match Column-I with Column-II and select the correct answer using the code given below the columns.

Column - I	Column - II
(a) Convex lens	(p) Used by makeup artists to see enlarged image of the face.
(b) Convex mirror	(q) Used as a magnifying glass
(c) Concave mirror	(r) Can form image of the object spread over a large area.
(d) Curved mirror	(s) Common example of a spherical mirror

Q4. This segment consists of two statements, one as "Assertion and the other as "Reason R". Read the two statements carefully and check if the Assertion A and Reason R are individually true and if so, whether the reason is a correct explanation of the assertion. Choose your correct answers to these items using codes given below.

- (a) Both A and R are true and R is the correct explanation of A.
- (b) Both A and R are true but R is the incorrect explanation of A.
- (c) A is true but R is false.
- (d) A is false but R is true.

I) Assertion (A): While you see in the side mirror of a car, the images of all objects appear smaller than the objects.

Reason (R): Side mirrors are convex mirrors.

Correct option.....

II) Assertion (A): For all the positions of an object, a convex lens always forms real images.

Reason (R): The rays are converged by the convex lens, and hence, forms the real image.

Correct option.....

Worksheet: 2 (Mode: Face to Face)

Learning Outcomes to be achieved:

Identifies materials and organisms, such as, animal fibres; types of teeth; mirrors and lenses on the basis of observable features, i.e., appearance, texture, functions, etc.

Q1. Identify the type of mirror drawn below, the blue side is the reflecting side and dots represent the polished side. Also write one property of this type of mirror in the space provided next to the figure



Q2. Bharath needs to install a parking mirror at the turn of a road for drivers to get a wide view of incoming traffic.

Which type of mirror should Bharath use as a parking mirror?

Q3. Visit a nearby hospital or a clinic of an ENT specialist. Request the doctor to show you the mirrors used for examining ear, nose and throat. Can you identify the kind of mirrors used in these instruments?

.....
.....
.....
.....

Q4. Write the nature (real/inverted) and size of the image formed by the mirror used by ENT Specialist.

.....



Q5. The above mirror is a concave/convex/plane mirror? Fill the table given below. Mark for correct option and for the incorrect option.

TYPE	CORRECT OPTION	INCORRECT OPTION	REASON(S)
CONVEX MIRROR	<input type="checkbox"/>	<input type="checkbox"/>	
PLANE MIRROR	<input type="checkbox"/>	<input type="checkbox"/>	
CONCAVE MIRROR	<input type="checkbox"/>	<input type="checkbox"/>	

Worksheet: 3 (Mode: Face to Face)

Learning Outcomes to be achieved:

Identifies materials and organisms, such as, animal fibres; types of teeth; mirrors and lenses on the basis of observable features, i.e., appearance, texture, functions, etc.

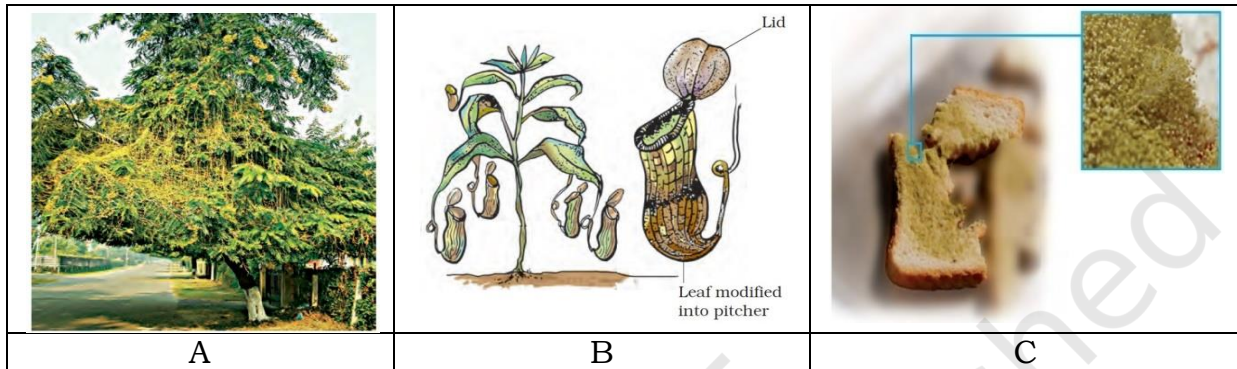

Q1. Identify the names of the plants given in Fig A,B and C according to the features visible in the figures. What are these plants known as according to their mode of nutrition?

Figure	Name of the Plant	Identifying feature	Mode of Nutrition
A			
B			
C			

Worksheet: 4 (Mode: Face to Face)

Learning Outcomes to be achieved:

Identifies materials and organisms, such as, animal fibres; types of teeth; mirrors and lenses on the basis of observable features, i.e., appearance, texture, functions, etc.

Q1.

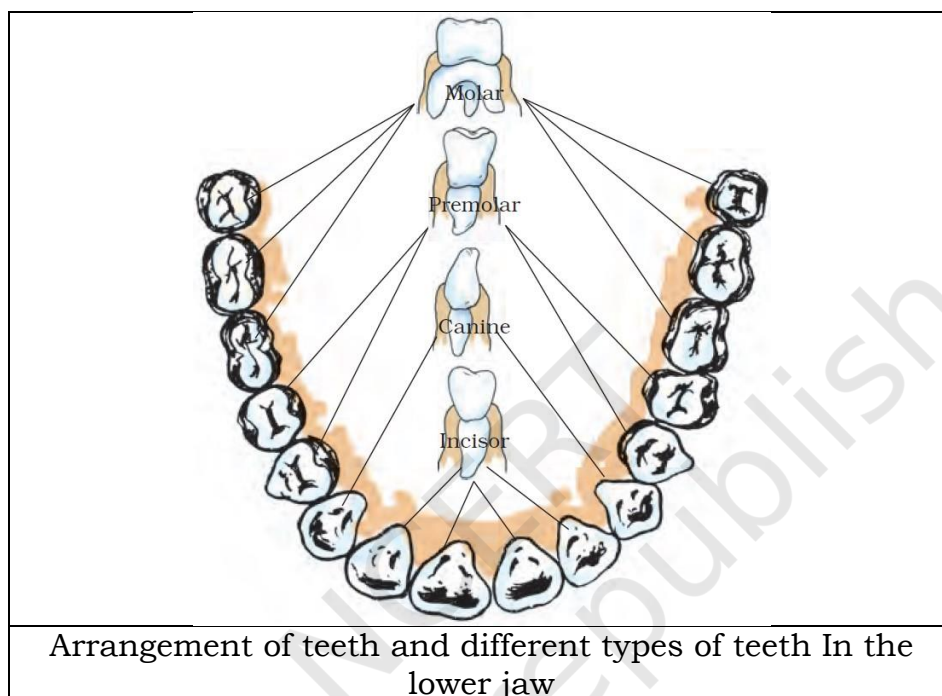

The arrangement of teeth in our upper and lower jaw is known as **dentition** and the representation of the complete set of teeth in symbols is called **dental notation**. You must have noticed that a dentist writes some symbols after identifying the tooth that is troubling you. The symbol is a short form that represents the exact position and type of tooth.

For example, Symbol L R= Lower jaw and Right side

Symbol L L= Lower jaw and Left side

A. So let us learn how to write a simple dental notation around the teeth of lower jaw in the figure itself.

HINT: Start counting one (1) from the centre towards the back of the jaw, on both sides, right and left.

B. Given below is a table with dental notation. Identify the different types of teeth on the basis of their position. Also write the function of each on the basis of their shape.

HINT: Start counting one (1) from the centre towards the back of your jaw, on both sides- right and left.

Dental notation	Type of Teeth (Right side of Lower jaw)	Function	Dental notation	Type of Teeth (Left side of Lower jaw)	Function
LR1			LL1		
LR2			LL2		
LR3			LL3		
LR4			LL4		
LR5			LL5		
LR6			LL6		
LR7			LL7		
LR8			LL8		

© NCERT
not to be republished

Worksheet: 5 (Mode: Face to Face)

Learning Outcomes to be achieved:

Identifies materials and organisms, such as, animal fibres; types of teeth; mirrors and lenses on the basis of observable features, i.e., appearance, texture, functions, etc.

Q1.

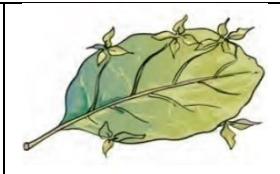
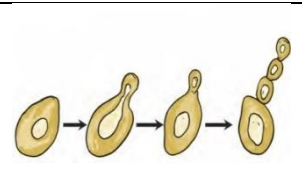
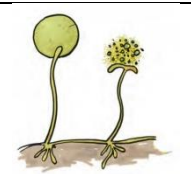
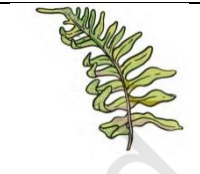
				
A. Potato	B. Bryophyllum leaf	C. Yeast cells	D. Fungus	E. Fern

Identify the structures in the figures through which new plants can be obtained through vegetative propagation. Write your answer in the table below.

Name of Plant	A. Potato	B. Bryophyllum leaf	C. Yeast cells	D. Fungus	E. Fern
Structure in the plant that leads to vegetative propagation					

Worksheet: 6 (Mode: Face to Face)

Learning Outcomes to be achieved:

Identifies materials and organisms, such as, animal fibres; types of teeth; mirrors and lenses on the basis of observable features, i.e., appearance, texture, functions, etc.

Q1. What will happen if all the seeds in the plant were to fall at the same place and grow there? Yes you are thinking rightly, there would be high competition of sunlight, water, minerals and space thereby result the seeds to grow into unhealthy plants. Therefore, dispersal of fruits and seeds benefit plants where dispersal enables them to invade new habitats for wider distribution. This happens because they have special structures for dispersal through various agents of dispersion, such as, water, wind, animals, mechanical pressure, etc.

			
Xanthium	Balsam plant	Coconut tree	Drumstick

Identify special structures in fruits and seeds that are responsible for their dispersal through various agents and complete the table given below:

Figure →	Seed of Drumstick	Fruit of Xanthium	Coconut tree	Balsam plant
Special structure useful in dispersal →				
Agent of dispersal of seed/fruit →				

Worksheet: 7 (Mode: Face to Face)

Learning Outcomes to be achieved:

Identifies materials and organisms, such as, animal fibres; types of teeth; mirrors and lenses on the basis of observable features, i.e., appearance, texture, functions, etc.

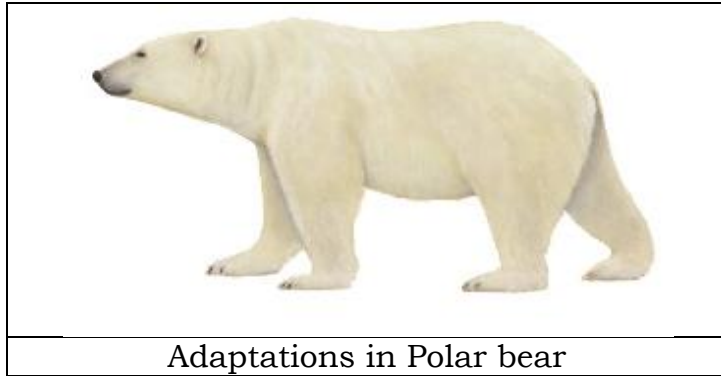

Q1. Identify physical features in Polar bears which help them to adapt for the following in the cold and windy environment of Arctic.

Adaptations in Polar bears	Physical features for adaptation
Camouflage	
Thermal insulation	
Locate its prey	
Walk on ice	

Worksheet: 8 (Mode: Online)

Learning Outcomes to be achieved:

Identifies materials and organisms, such as, animal fibres; types of teeth; mirrors and lenses on the basis of observable features, i.e., appearance, texture, functions, etc.

- Q1. Boojho and Paheli are holding one mirror each their hand. While seeing the mirror, Paheli found her image erect and smaller in size whereas Boojho found his image to be erect and of the same size. The difference in their images size means that the mirrors of Boojho and Paheli are
- (a) Concave mirror and Plane mirror respectively.
 - (b) Convex mirror and concave mirror respectively.
 - (c) Plane mirror and convex mirror respectively.
 - (d) Convex mirror and plane mirror respectively.
- Q2. In order to get an inverted image from mixture of a convex mirror, a concave mirror, a convex lens and a concave lens, you will select....
- (a) Both concave lens and convex lens.
 - (b) Both concave mirror and convex mirror.
 - (c) Both concave mirror and convex lens.
 - (d) Both convex mirror and concave lens.
- Q3. What is called the type of lens, which is thicker in the middle and thinner at the edges and is used as magnifying glass?
- (a) Convex lens
 - (b) Concave lens
 - (c) Diverging lens
 - (d) None of these
- Q4. Of the following mirrors, which one will provide images of large areas and is used for security?
- (a) A plane mirror.
 - (b) A concave mirror
 - (c) A convex mirror
 - (d) All of the above
- Q5. While reading small letters found in a dictionary, which of the following would you prefer to use?
- (a) A concave mirror
 - (b) A concave lens
 - (c) A convex mirror
 - (d) A convex lens

Worksheet: 9 (Mode: Online)

Learning Outcomes to be achieved:

Identifies materials and organisms, such as, animal fibres; types of teeth; mirrors and lenses on the basis of observable features, i.e., appearance, texture, functions, etc.

- Q1. When seen from a close distance in a convex mirror, the face image
- (a) has same size
 - (b) is enlarged
 - (c) is diminished
 - (d) is blurred
- Q2. Which of the following image is formed by the convex lens?
- (a) A magnified image wherever the object is place
 - (b) A magnified image only when the object is very close
 - (c) A diminished and erect images
 - (d) No image
- Q3. When you look at the shining surface of the bell of your bicycle, the smaller and erect image is formed by which lens/mirror?
- (a) convex lens
 - (b) convex mirror
 - (c) concave lens
 - (d) concave mirror
- Q4. Identify the correct option on the basis of following features.
- (I) Virtual and erect image is formed
 - (II) Image size is equal to size of object
 - (III) Lateral inversion of the object's image.
- (a) Concave mirror
 - (b) Convex mirror
 - (c) Plane mirror
 - (d) Both (a) and (b)
- Q5. Which of the following cases is/are possible for convex lens?



- (a) (i) and (ii) (b) (ii) and (iii) (c) (iii) and (i) (d) Only (i)

- Q6. Select the correct option of the converging mirror and diverging lens from the following-
- (a) Concave mirror and convex lens respectively.
 - (b) Convex mirror and convex lens respectively.
 - (c) Convex mirror and concave lens respectively.
 - (d) Concave mirror and concave lens respectively.
- Q7. The lens which forms the following are
- i) Virtual and magnified image
 - ii) Virtual and diminished image are
- (a) Both are converging lens
 - (b) Both are diverging lens
 - (c) (i)converging lens and (ii)diverging lens
 - (d) (i)diverging lens and (ii)converging lens
- Q8. Eye lens in our eyes makes a real and inverted image at the retina. What is the nature of the eye lens
- (a) concave lens
 - (b) convex lens
 - (c) Can be either concave or convex lens
 - (d) One side concave and other side convex lens.

Worksheet: 10 (Mode: Online)

Learning Outcomes to be achieved:

Identifies materials and organisms, such as, animal fibres; types of teeth; mirrors and lenses on the basis of observable features, i.e., appearance, texture, functions, etc.



Cuscuta on host plant

- Q1. Yellow tubular structures of Cuscuta twine around the stem and branches of a tree--
- (a) To reach sunlight above the host plant
 - (b) To get support for its weak stem from the host plant
 - (c) To absorb nutrients from the host plant
 - (d) To add beauty to the host plant

Worksheet: 11 (Mode: Online)

Learning Outcomes to be achieved:

Identifies materials and organisms, such as, animal fibres; types of teeth; mirrors and lenses on the basis of observable features, i.e., appearance, texture, functions, etc.

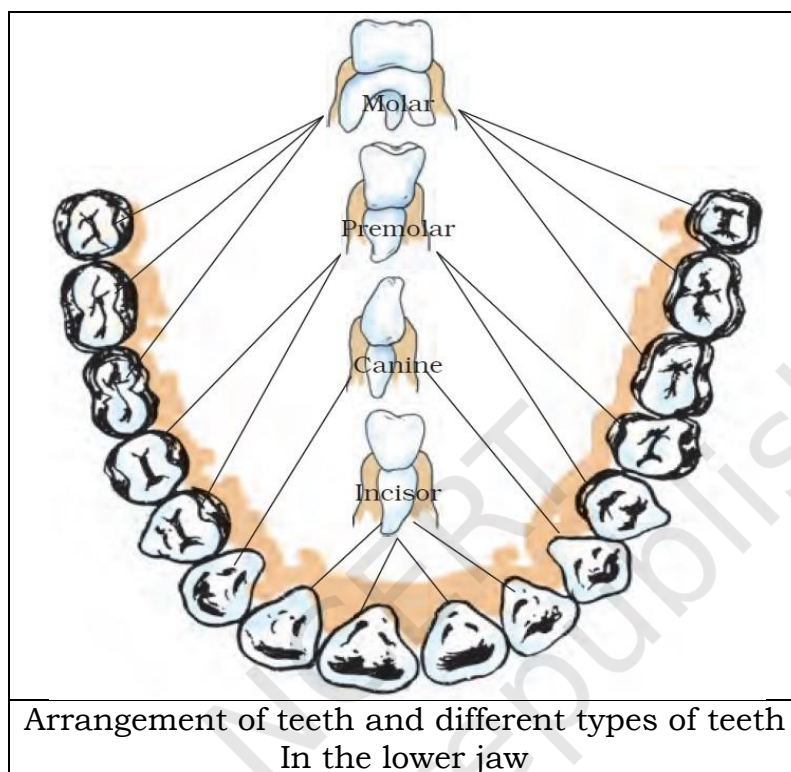

Q1. You are given a long piece of washed sugarcane stem. In which order will you use your different types of teeth to enjoy the sweet juice of sugar cane, piece by piece?

- (a) a. Canine b. Molars and Premolars c. Incisors
- (b) a. Canine b. Incisors c. Molars and Premolars
- (c) a. Incisors b. Canine c. Molars and Premolars
- (d) a. Molars and Premolars b. Canine c. Incisors

Worksheet: 12 (Mode: Online)

Learning Outcomes to be achieved:

Identifies materials and organisms, such as, animal fibres; types of teeth; mirrors and lenses on the basis of observable features, i.e., appearance, texture, functions, etc.

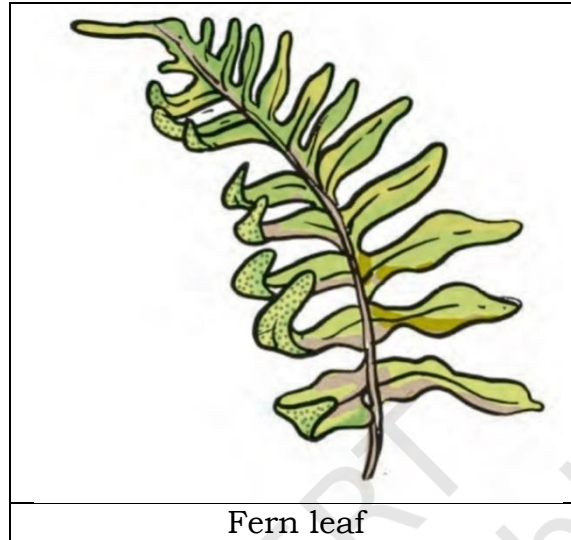



- Q1. The brown dots seen in the margin of the leaf are due to?
- (a) Formation of dry spots at the margins
 - (b) Infestation of leaf with very small insects
 - (c) Formation of sori on the under surface of the leaf
 - (d) Lack of nutrition in the fern plant

Worksheet: 13 (Mode: Online)

Learning Outcomes to be achieved:

Identifies materials and organisms, such as, animal fibres; types of teeth; mirrors and lenses on the basis of observable features, i.e., appearance, texture, functions, etc.

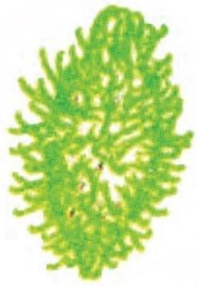
Q1. What do you think will happen if all the seeds in the plant were to fall at the same place and grow there? There would be severe competition of sunlight, water, minerals and space. As a result the seeds would not grow into healthy plants. Therefore, plants benefit by dispersal of fruits and seeds. It enables them to invade new habitats for wider distribution. This happens because they have special structures for dispersal through various agents of dispersion, such as, water, wind, animals, mechanical pressure, etc.

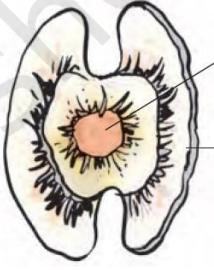
			
A. Xanthium	B. Balsam plant	C. Coconut tree	D. Drumstick

Seeds of which plant will be dispersed when the fruit bursts with sudden jerks?

- (a) Xanthium
- (b) Balsam plant
- (c) Coconut tree
- (d) Drumstick

Worksheet: 14 (Mode: Online)

Learning Outcomes to be achieved:

Identifies materials and organisms, such as, animal fibres; types of teeth; mirrors and lenses on the basis of observable features, i.e., appearance, texture, functions, etc.

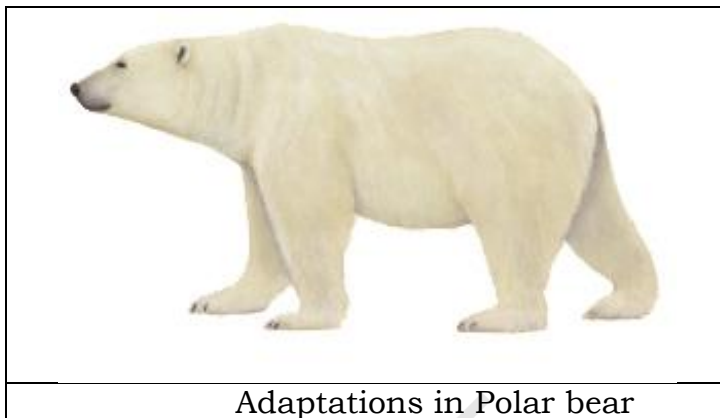

- Q1. Identify the adaptive feature in polar bears which helps it to camouflage.
- A. Short ears and tail
 - B. Layer of fat under the skin
 - C. Two thick layers of fur
 - D. White fur

Worksheet: 15 (Mode: Face to Face) (LO-2)

Learning Outcomes to be achieved:

Differentiates materials and organisms such as, digestion in different organisms; unisexual and bisexual flowers; conductors and insulators of heat; acidic, basic and neutral substances; images formed by mirrors and lenses, etc., on the basis of their properties, structure and function.

Flowers are the reproductive parts of a plant. **Stamen** is the male reproductive part and **pistil** is the female reproductive part.

Flowers which contain either stamen or pistil are called **Unisexual flowers**.



Flowers which contain both stamen and pistil are called **Bisexual flowers**.



1. Label the female and male parts of the flower and what is it collectively called

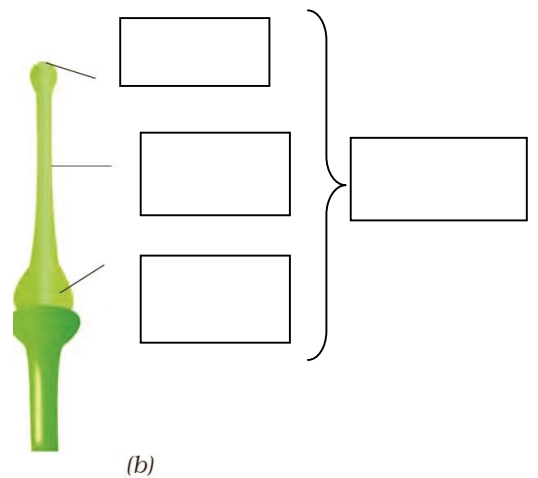
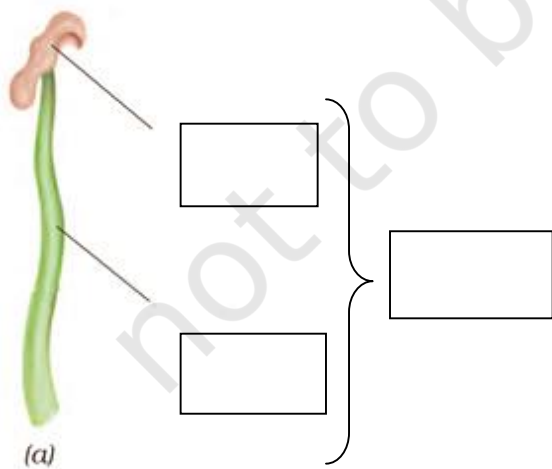

1. Correct the given statements:

- (i) The sticky tip of style is called the filament.
.....
- (ii) Unisexual flowers contain both stamens and pistil.
.....
- (iii) Corn flowers are bisexual flowers.
.....
- (iv) Anther is the female part of the flower that consists of stamens and filament.
.....
- (v) Bisexual flowers contain either only pistil or only stamens.
.....
- (vi) Tiny structures present inside the ovary of a flower are called pollen grains
.....
- (vii) Another contains pollen grains and ovary contains one or more ovule
.....
- (viii) Mustard, rose and petunia are unisexual flowers.
.....
- (ix) Corn, Papaya and Pumpkin are bisexual flowers.
.....
- (x) The transfer of pollen from the anther to the stigma of a flower is called pollination.
.....

Worksheet: 16 (Mode: Online)

Learning Outcomes to be achieved:

Differentiates materials and organisms such as, digestion in different organisms; unisexual and bisexual flowers; conductors and insulators of heat; acidic, basic and neutral substances; images formed by mirrors and lenses, etc., on the basis of their properties, structure and function.

Q1. Learners were given substances A, B, C and D to record their taste. Substances A and C were reported sour taste and substances B and D were reported bitter taste. On the basis of tasted above substances can be classified as

- (a) A, C – Acidic; B, D- Basic
- (b) A, C – Basic; B, D- Acidic
- (c) A, C – Acidic; B, D- Acidic
- (d) A, C – Basic; B, D- Basic

Q2. In a class students were given aqueous solutions marked as A, B and C with indicators China rose extract, phenolphthalein and turmeric powder. Following observations were recorded by the students

- I. With China rose extract, Solution A gives dark pink (magenta) colour
- II. With phenolphthalein, Solution B gives pink colour
- III. With turmeric powder, Solution C gives red colour

On the basis of above observations it can be concluded that solutions A, B and C are, respectively

- (a) Acidic, Basic, acidic
- (b) Acidic, basic, basic
- (c) Basic, Acidic, acidic
- (d) Acidic, basic, basic

Q3. In a class learners were asked to perform the following activity:

Take some hydrochloric acid in a test tube and add 2–3 drops of the phenolphthalein indicator in it. Now add some sodium hydroxide solution and observe colour change. Again add some hydrochloric acid and observe colour change. This activity demonstrates

- (a) Acidic behaviour of substances
- (b) Basic behaviour substances
- (c) Neutralization process
- (d) Acidic as well as basic behaviour of hydrochloric acid

Q4. In an activity in the class a drop of aqueous lemon juice was put on strips of the red and blue litmus papers. The colour change of litmus papers in the above activity is

- (a) Red- blue and blue-red
- (b) Blue - red and red -blue

- (c) Red- blue and blue-blue
- (d) Blue - red and red-red

Q5. Consider the following materials

- (i) Aluminium (ii) iron (iii) copper (iv) plastic and (vi) wood

The materials which allow heat to pass through them easily are

- (a) (i), (ii), (iii)
- (b) (ii), (iii), (iv)
- (c) (iii), (iv), (vi)
- (d) (i), (ii), (iv)

Q6. Consider the image of a child using the inner side of the spoon given below-



The inner surface of a spoon acts like a

- (a) Concave mirror
- (b) Convex mirror
- (c) Plane mirror
- (d) Concave lens

Worksheet: 17 (Mode: Face to Face) (LO-3)

Learning Outcomes to be achieved:

Classifies materials and organisms based on properties/ characteristics, e.g., plant and animal fibres; physical and chemical changes

- Classifies materials as acidic, basic and neutral on the bases of their properties.
- Relates scientific concept in daily-to-day life.



Q1. Sonia wrote an invisible message to Riyaz on a piece of paper. On rubbing the beetroot solution over the paper, the message appeared clearly. Name the solution with which Sonia had written the message.

Q2. Complete the following table –

NATURAL INDICATORS	SAMPLES	COLOUR CHANGE OBSERVED
Litmus	Tamarind solution	_____
China Rose	Baking soda	_____
Red Cabbage Juice	_____	Green
_____	Soap solution	Red
Beetroot Juice	_____	No Colour Change

Q3. Palak while playing on the terrace got beaten by bee. Her mother quickly rubbed some solution on the affected area to her relief. Name the solution and its role here.



Worksheet: 18 (Mode: Online)

Learning Outcomes to be achieved:

Classifies materials and organisms based on properties/ characteristics, e.g., plant and animal fibres; physical and chemical changes

- Q1. Given below is a sequence of steps in the processing of wool. Shearing, rolling, dyeing, sorting, scouring. Tick the correct sequence in the processing of wool.
- shearing b) dyeing c) sorting d) scouring e) rolling
 - Shearing b) sorting c)scouring d)dyeing e) rolling
 - Shearing b)scouring c)sorting d) dyeing e)rolling
 - Rolling b) shearing c) sorting d) dyeing e) scouring
- Q2. Fibres may be classified as animal, plant and synthetic fibre. Select the animal fibre from the following.
- Wool and nylon
 - Silk and polyester
 - Jute
 - Silk and wool
- Q3. When carbon dioxide is passed through lime water, calcium carbonate is formed, which makes lime water milky which is regarded as a standard test of carbon dioxide. Select the right option from the following for the above process.
- Physical change
 - Chemical change
 - Natural change
 - Reversible change
- Q4. Iron pillar near the Qutub Minar in Delhi is famous for its long stability because of the following fact.....
- Its height is more than 7 metres
 - It weight is about 6000 kg
 - It is more than 1600 years ago
 - Iron has not been rusted after such a long period
- Q5. Preeti's mother made concentrated sugar syrup by dissolving sugar in hot water. On cooling, crystals of sugar got separated. This indicates a
- Physical change that can be reversed
 - Chemical change that can be reversed
 - Physical change that cannot be reversed
 - Chemical change that cannot be reversed

Q6. When you cut an apple with knife interactions between the apple and the knife take place and a brown spot is on apple appears. This indicates a:

- a) Physical change that can be reversed
- b) Chemical change that can be reversed
- c) Physical change that cannot be reversed
- d) Chemical change that cannot be reversed

© NCERT
not to be republished

Worksheet: 19 (Mode: Online)

Learning Outcomes to be achieved:

Classifies materials and organisms based on properties/ characteristics, e.g., plant and animal fibres; physical and chemical changes

- Q1. Harbir and Bob brought pieces of cloth from the neighborhood tailor to stick in their portfolio. They burnt a thread of each type of fibre they had collected with help of their father and noted their observations. Help them classify them into plant and animal fibre-
- A) Silk Fibre- Burns with the smell of burning hair and a bead is formed which can be crushed into greyish powder.
 - B) Cotton Fibre-Burns with the smell of burning paper, ash produced
 - C) Wool Fibre-Burns with the smell of burning hair and a bead is formed which can be crushed into greyish powder.
 - D) Jute Fibre-Burns with the smell of burning paper and ash is produced
- (a) A and B - animal fibres, C and D- plant fibres
 - (b) A and C - animal fibres, B and D- plant fibres
 - (c) B and C - animal fibres, A and D- plant fibres
 - (d) A and D - animal fibres, B and C- plant fibres

Worksheet: 20 (Mode: Online)

Learning Outcomes to be achieved:

Classifies materials and organisms based on properties/ characteristics, e.g., plant and animal fibres; physical and chemical changes

Q1. Mohit and Jyoti were given silk, cotton, wool and jute fibres and were told to classify them as plant and animal fibres. They conducted a small investigation by burning a thread of each type of fibre. Choose the correct basis of their classification-

- A) Animal Fibres burn with the smell of burning hair and a bead is formed which can be crushed into greyish powder.
 - B) Plant Fibres burn with the smell of burning hair and a bead is formed which can be crushed into greyish powder.
 - C) Animal fibres burn with the smell of burning paper, ash produced
 - D) Plant fibres burn with the smell of burning paper, ash produced
- (a) A
 - (b) B
 - (c) A and D
 - (d) B and C

Worksheet: 21 (Mode: Online)

Learning Outcomes to be achieved:

Classifies materials and organisms based on properties/ characteristics, e.g., plant and animal fibres; physical and chemical changes

Q1. Ravneet and Pritha made China rose (Gudhal) extract and used it as indicator to test each of the given solution and help them classify them as acidic, basic and neutral-

Solution	Test Solution	Final Colour
A	Lemon Juice	Dark pink (magenta)
B	Sugar solution	No change
C	Shampoo(dilute solution)	Green
D	Vinegar	Dark pink (magenta)
E	Common salt solution	No change
F	Sodium hydrogen carbonate solution	Green

- (a) A and D -acidic; B and E-Neutral: C and F-Basic
(b) A and D -basic; B and E-Neutral: C and F-acidic
(c) A and D -acidic; B and E-Basic : C and F-Neutral
(d) A and D -basic; B and E-acidic: C and F-Neutral

Worksheet: 22 (Mode: Online)

Learning Outcomes to be achieved:

Classifies materials and organisms based on properties/ characteristics, e.g., plant and animal fibres; physical and chemical changes

- Q1. Giridhar and Lovely found that coffee, vinegar and lemon juice turned blue litmus solution red and lime water, window cleaner and soap solution turned red litmus solution blue. What inference did they deduce-
- (a) Coffee, vinegar, lemon juice are acidic in nature and lime water, window cleaner , soap solution are basic in nature
 - (b) Coffee, vinegar, lemon juice are basic in nature and lime water, window cleaner , soap solution are acidic in nature
 - (c) Coffee, vinegar, lemon juice are acidic in nature and lime water, window cleaner , soap solution are neutral in nature
 - (d) Coffee, vinegar, lemon juice are neutral in nature and lime water, window cleaner , soap solution are acidic in nature

Worksheet: 23 (Mode: Online)

Learning Outcomes to be achieved:

Classifies materials and organisms based on properties/ characteristics, e.g., plant and animal fibres; physical and chemical changes

Q1. Harleen and Cheeku of team 'A' added salt to water. It became salty. Ashwin and Sehaj of team 'B' dropped a nail into blue coloured copper sulphate solution. After half an hour they observed that the colour of the solution had changed to pale green and there was brown deposit on the iron nail. Both the teams reported their findings-

- (i) Team A- Physical Change; Team B- Chemical Change
- (ii) Team A- Change that can be reversed; Team B-Change that cannot be reversed
- (iii) Team A- Change that cannot be reversed; Team B-Change that can be reversed
- (iv) Team A- Chemical Change; Team B- Physical Change

Choose the correct statement from the following regarding the change?

- (a) (i) and (iii) (b) (i) and (ii) (c) (iii) and (iv) (d) (ii) and (iv)

Worksheet: 24 (Mode: FACE-TO -FACE) (LO-4)

Learning Outcomes to be achieved:

Conducts simple investigations to seek answers to queries, e.g., can extract of coloured flowers be used as acid-base indicator? Do leaves other than green also carry out photosynthesis? Is white light composed of many colours?

LET'S MAKE A NEWTON'S DISC

Find a cardboard disc and cut it circular shape of about 10 cm diameter. Now divide this disc into seven segments with the help of pencil. Then on these segments, paint the seven rainbow colours as shown in Figure or paste, coloured papers on these segments. At the centre of the disc, make a small hole so that the disc can fix loosely on the tip of a refill of a ball pen ensuring the free rotation of the disc. In the broad daylight, while rotating the disc fast, the colours get mixed together and the disc appears to be whitish.

Q1. What was your observation when the disc was rotated very fast?

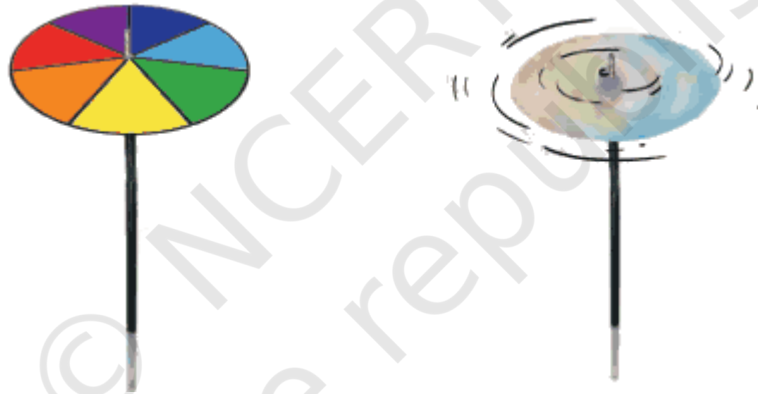

Q2. If the disc was rotated slowly, was the observation similar to when it was rotated fast? Support your answer with the reason.

.....
.....
.....

Q3. What did you conclude from the above experiment?

.....
.....
.....

Q4. When light is reflected from the surface of a Compact Disk (CD), you see many colors. The figure below shows the result. Is there any similarity with the Newton's disc experiment? Explain your answer

.....

.....
.....



Q5. Rahul conducted the simple experiment in the lab with a prism and a laser light. In first experiment he took a laser light with yellow colour and in the second experiment he took laser light with white colour.(Please note he took same prism for both the experiments) Discuss the reason for the observation shown below

.....
.....
.....

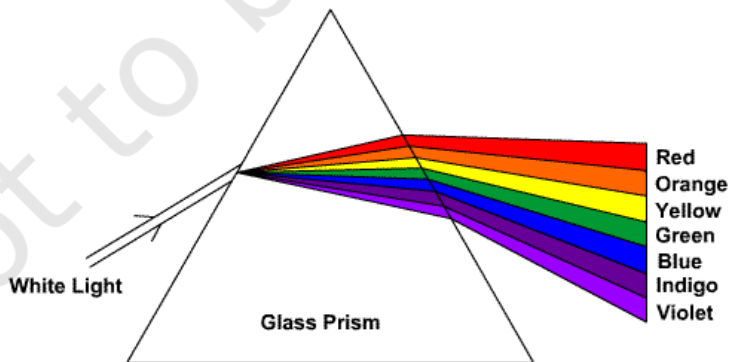
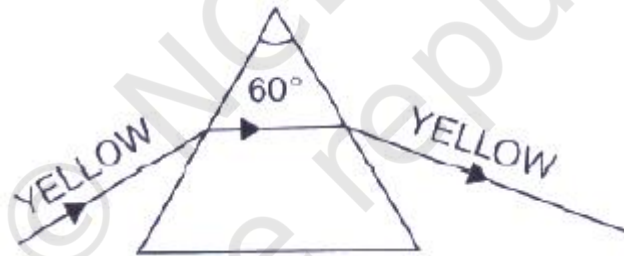

Worksheet: 25 (Mode: FACE-TO -FACE)

Learning Outcomes to be achieved:

Conducts simple investigations to seek answers to queries, e.g., can extract of coloured flowers be used as acid-base indicator? Do leaves other than green also carry out photosynthesis? Is white light composed of many colours?

Q1. Harleen took 5 mL of dilute hydrochloric acid in a test-tube. She added 1-2 drops of phenolphthalein solution to it and stirred the solution gently with a glass rod.

What change did she observe in the colour of the acid?

.....

Q2. Then, with the help of a dropper, she added 5 mL dilute sodium hydroxide solution drop by drop into the mixture of dilute hydrochloric acid and phenolphthalein solution with constant stirring.

What did she observe?

.....

Q3. With the help of another dropper, she took out hydrochloric acid and started adding it drop wise into the above mixture. Did Harleen observe any change in the colour of the solution?

.....

Q4. What is the role of phenolphthalein solution here?

.....
.....



Worksheet: 26 (Mode: FACE-TO -FACE)

Learning Outcomes to be achieved:

Conducts simple investigations to seek answers to queries, e.g., can extract of coloured flowers be used as acid-base indicator? Do leaves other than green also carry out photosynthesis? Is white light composed of many colours?

Q1.

Test Solution	Effect on Turmeric Solutions	Remarks
lemon juice	remains yellow	
milk of magnesia	reddish brown	

Mohan has observed the above observations after doing the experiment with turmeric solutions. Complete the remarks (with lemon juice) by suitable options given

- a) Acidic or Neutral b) Basic or Neutral c) Basic d) Can't say

Q2. Complete the remarks (with milk of magnesia) by suitable options.

- a) Basic and neutral
b) Acidic and neutral
c) Basic only
d) Acidic only.



Q3. Add some sodium hydroxide solution to the acidic solution using a dropper in a tube and stir gently. Do you observe any colour change in the solution? If not, continue adding the sodium hydroxide solution drop by drop while stirring until the pink colour just appears.

Now if you add one more drop of dilute hydrochloric acid, the solution again becomes colourless. Again if you add one drop of sodium hydroxide solution, the solution again becomes pink in colour.

After the observations of the above experiments concludes the following
In acidic solutions the colour of the phenolphthalein is.....

- a) Light pink b) Dark pink c) Blue d) Colourless

Q4. In basic solutions the colour of the phenolphthalein is.....

- a) Blue b) Colourless c) Pink d) Red

Q5. Indicator is a substance which changes colour in different mediums and indicates the substances as acidic, basic or neutral. Select the synthetic indicator from the following options.

- a) china rose b) turmeric c) phenolphthalein d) litmus.

Q6. Mohan wants to give her mom a greeting card on mother's birthday. He prepares greeting cards with the help of turmeric paste and he also wants to add some reddish brown colour in the greeting card. Suggest Mohan a suitable material that help him to prepare a card is.....

- a) Vinegar solution
- b) Soap solutions
- c) Mustard oil
- d) Oxalic acid

© NCERT
not to be republished

Worksheet: 27 (Mode: FACE-TO -FACE)

Learning Outcomes to be achieved:

Conducts simple investigations to seek answers to queries, e.g., can extract of coloured flowers be used as acid-base indicator? Do leaves other than green also carry out photosynthesis? Is white light composed of many colours?

Q1. Do the given experiment as follow instructions and answer the following questions.

Take a metal rod and on it stick paper pins with wax and keep a lighted candle below the rod as shown in the diagram below.

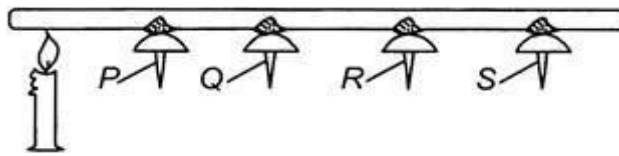

Of the four paper pins which one will fall off the metal rod first?

- (a) P
- (b) O
- (c) R
- (d) S

Ans:

What does the above experiment illustrate?

Ans:.....
.....
.....

Q2. Rita wanted to keep her canned juice cold on a school picnic. Her other two friends also brought the canned juice. They had three materials with them: bubble pack, cotton wool and aluminum foil. Each one took one material and wrapped their can of juice. Which canned drink will remain cold the longest and why?

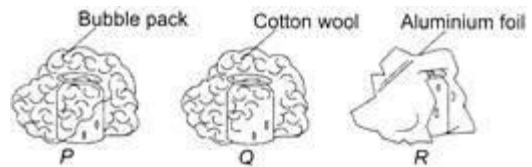

- (a) P
- (b) O
- (c) R
- (d) Both P and Q

Ans:.....
.....
.....

Q3. Rohan wants to test whether a white object or a black object would heat up faster in the Sun. The given picture shows you his experiment. These thermometers were left out in the Sun for 30 minutes.

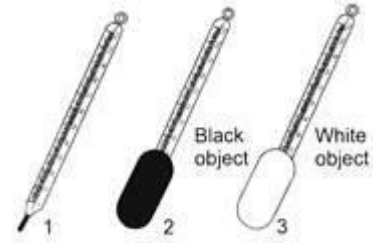

Which of the following thermometer will show the higher temperature out of 2 and 3 and why?

Ans:.....

Q4. Take two glass test tubes. Put water in it. They are heated in two different directions. The two directions are marked with arrows. In which test tube the water heats up fast if it is kept for same time on flame.

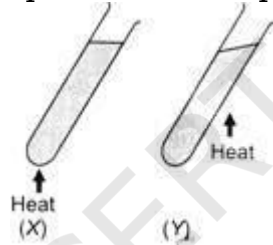

Ans:.....

Q5. Give reason for the above answer, also mention the mode of transfer of heat taking place

Ans:.....

Worksheet: 28 (Mode: Online)

Learning Outcomes to be achieved:

Conducts simple investigations to seek answers to queries, e.g., can extract of coloured flowers be used as acid-base indicator? Do leaves other than green also carry out photosynthesis? Is white light composed of many colours?

- Q1. In the physics lab, Merriam rotates Newton's colour dice rapidly. A boy is observing the experiment. What he has observed in this experiment?
- (b) Seven colours of light looks like two colours of white and black
 - (c) Seven colours of light looks like single colour of black
 - (d) Seven colours of light looks like single colour of white
 - (e) All of these
- Q2. On passing a narrow beam of white light (sunlight or torch light) through a triangular glass prism, it splits into a band of seven colours in order violet, indigo, blue, green, yellow, orange and red (VIBGYOR). The violet colour is deviated the most while the red colour is deviated the least.

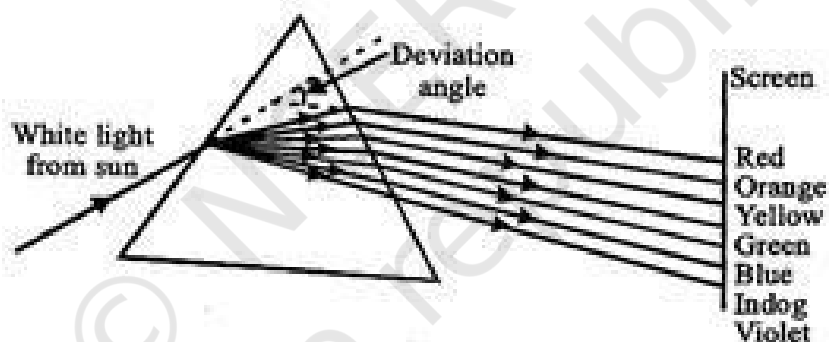

- (a) The sunlight is white
- (b) The sunlight consists of five colours
- (c) The sunlight consists of seven colours
- (d) Both (a) and (c)

Q3.

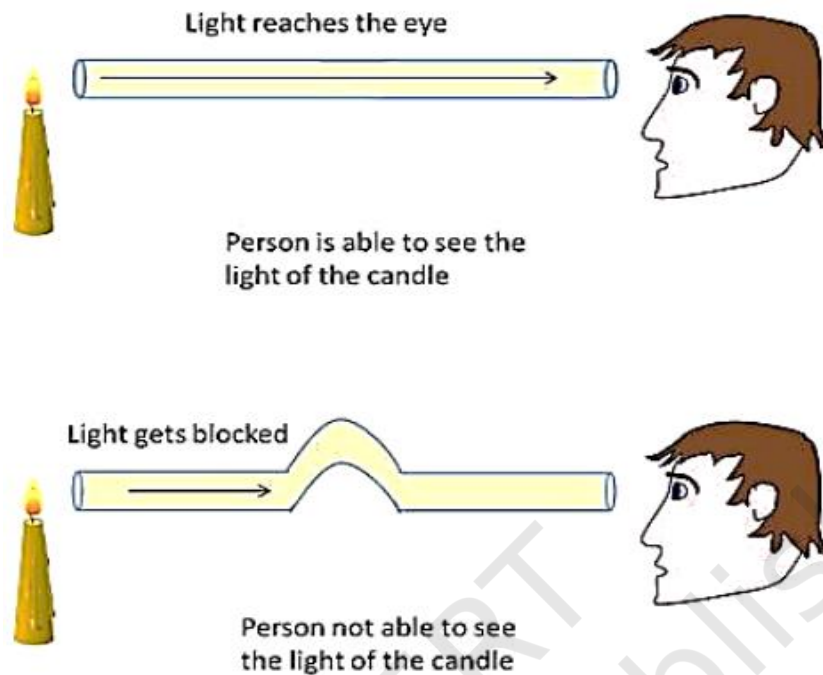

The most appropriate reason (s) for the above experiment is

- (i) Light is made up of seven colours
- (ii) Light follows rectilinear propagation
- (iii) Light follows laws of reflection
- (iv) Light gets blocked in the figure with the bent pipe

Options

- (a) only (I)
- (b) only (ii)
- (c) and (ii) only
- (d) (ii) and (iv) only

Q4. In nature, rainbow is formed due to the dispersion of sunlight. The optical aid responsible for it is/are:

- (a) molecules of carbon dioxide
- (b) tiny droplets of water
- (c) molecules of nitrogen dioxide
- (d) dust particles

Q5: The colour that deviates least during the dispersion of white light is:

- (a) violet
- (b) green
- (c) red
- (d) orange

Worksheet: 29 (Mode: Online)

Learning Outcomes to be achieved:

Conducts simple investigations to seek answers to queries, e.g., can extract of coloured flowers be used as acid-base indicator? Do leaves other than green also carry out photosynthesis? Is white light composed of many colours?

Q1. An iron rod and a wooden rod are wrapped together in a piece of paper and were then heated as shown in the figure. It was observed that the paper around the wooden rod catches fire whereas the one the iron rod does not burn. It is because

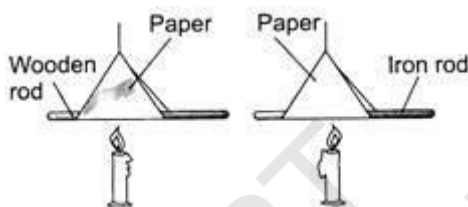

- (a) In case of iron rod, candle is nearer to the paper.
 - (b) In case of wood, being a bad conductor of heat, it takes away all the heat.
 - (c) Iron conducts away the heat given to the paper due to its nature of being good conductor of heat.
 - (d) Due to thickness of Paper.
- Q2. Tina needs a box which can absorb the heat from the sun very fast but lose it very slowly. How should the outer and the inner surface of the box be colored so that he gets the best result?
- (a) Outer-Silver/Inner: Silver
 - (b) Outer-Black/Inner: Black
 - (c) Outer - Silver, Inner :Black
 - (d) Outer - Black, Inner : Silver
- Q3. There are four cups made of different materials: Silver, aluminum, wood and copper. Which tea cup will remain warm for a longer time?
- (a) Silver cup
 - (b) Aluminum cup
 - (c) Wooden cup
 - (d) Copper cup
- Q4. Pass a light candle and keep his one hand above the candle flame and one hand on the side of the flame. Which hand feels hot first and in this case, what is the mode of transfer of heat?

- (a) The hand that was kept above the flame and mode of transfer of heat is convection
- (b) The hand that was kept on the side of the flame and mode of transfer of heat is radiation
- (c) Both hands feel equally hot and mode of transfer of heat is radiation
- (d) The hand that was kept above the flame and mode of transfer of heat is conduction.

Q5. In the given figure, the temperature of the water in cup A and cup B at the beginning of a heat-flow experiment is shown by the thermometers.

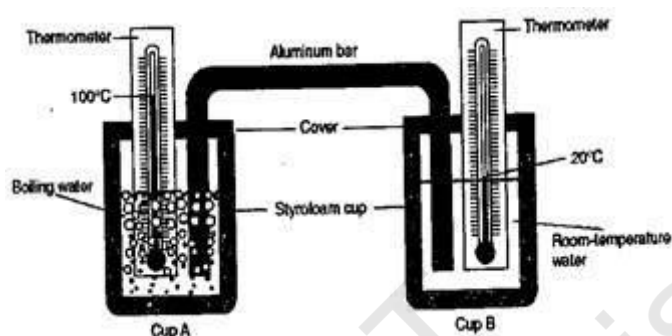

What temperature changes would most likely occur in over the next 15 minutes?

- (a) Cup A will decrease and Cup B will increase.
- (b) Cup A will decrease and Cup B will decrease.
- (c) Cup A will increase and Cup B will increase.
- (d) Cup A will increase and Cup B will decrease.

Q6. On the basis of following diagram/ picture of a metal ball and a metal ring answer the questions given below:

Through the hole of a metal ring formed out of a strip, the metal ball can just pass. In case of the metal ball is heated it gets stuck but what will happen if the metal ring is heated?

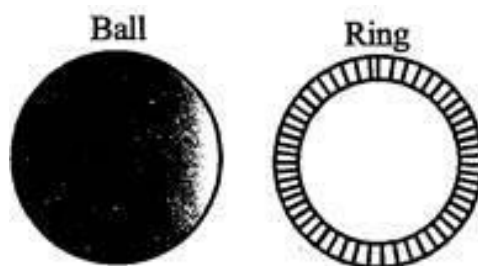

- (a) There is no change in the ring, so the ball will not pass through it.
- (b) The ring diameter expands on heating and hence the ball can now pass through it.
- (c) The diameter of the hole decreases on expansion, therefore the ball gets stuck.
- (d) None of the above

Q7. On the basis of following diagram/ picture, it shows air-filled bulbs connected by a U-tube partly filled with alcohol. When an electric bulb is placed midway between the painted air filled bulbs and electric bulb is lighted, observe the changes to the levels of alcohol in the limbs X and Y?

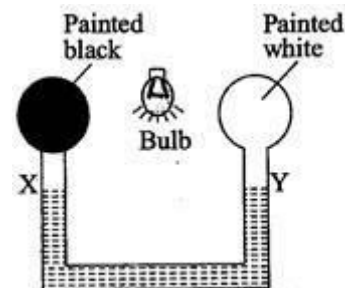

- (a) In both limbs, the level of alcohol falls.
 - (b) The level of alcohol in the limb Y falls while that in limb X rises as the bulb painted white absorbs more heat and expands the air inside it..
 - (c) The level of alcohol in limb X falls while that in limb Y rises as black bulb absorbs more heat and expands the air inside it.
 - (d) No change in the levels of alcohol in the two limbs.
- Q8. In a car, radiator and fan are used to cool the engine. The heat transfer modes involved are
- (a) conduction and convection
 - (b) convection and radiation
 - (c) conduction and radiation
 - (d) conduction, convection and radiation

Worksheet: 30 (Mode: Online)

Learning Outcomes to be achieved:

Conducts simple investigations to seek answers to queries, e.g., can extract of coloured flowers be used as acid-base indicator? Do leaves other than green also carry out photosynthesis? Is white light composed of many colours?

Q1. Komal and Bob had learnt effect of blue and red litmus paper on acids and bases. But during lockdown they wanted to conduct simple investigation to know if extract of colored flowers be used as an acid-base indicator?

To help them proceed to identify Acids, Bases and Salts arrange the following steps in correct sequence and make diagrams of the set-up.

A.They took some warm water in a beaker and added some China rose (*Gudhal*) petals in it.

B.They added a drop of each of the solutions to be tested one by one, on China rose extract.

C.Then the mixture was filtered. This way they prepared light pink coloured solution of China rose indicator.

D.They concluded that detergent solution, soap solutions are basic solutions as the colour of china rose indicator turns from pink to green in basic solutions. Aerated drink, lime, lemon juice and curd are acidic solutions as the colour of china rose indicator turns from pink to dark pink (magenta) in acidic solutions

E.They collected detergent solution, aerated drink, lime, soap solution, lemon juice and curd to be tested.

G. They recorded	Observations :
Solution	Effect on China Rose
Detergent solution	Turns green
Aerated drink	Turns dark Pink
Lime	Turns dark Pink
Soap solution	Turns green
Lemon Juice	Turns dark Pink
Curd	Turns dark Pink

F.The mixture was allowed to stand undisturbed for sometime till the water became coloured.

Worksheet: 31 (Mode: Face to Face) (LO-5)

Learning Outcomes to be achieved:

Relates processes and phenomena with causes, e.g., wind speed with air pressure; crops grown with types of soil; depletion of water table with human activities, etc.

Q1. Anand was playing with a funnel and a ping pong ball. He kept the open end of the funnel towards the ceiling and placed a ping pong ball in it. Then he tried to shoot the ball high up by blowing air into the funnel. However, he observed that the ping pong continues to stay at the base of the funnel instead of flying out of it.

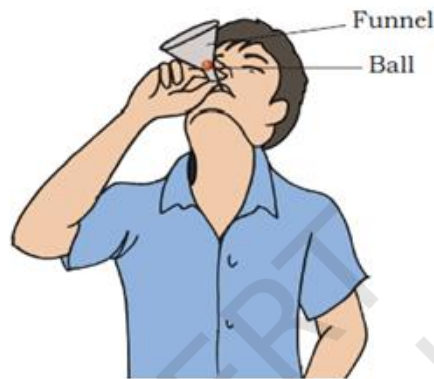

Help Anand solve the mystery of his observation by giving appropriate reason.

© NCFE be republished

Q2. Anandi was conducting crushing can experiment. As shown in the diagram, at first, she heated some water till it boiled. Then she closed its lid immediately and poured some cold water on it.

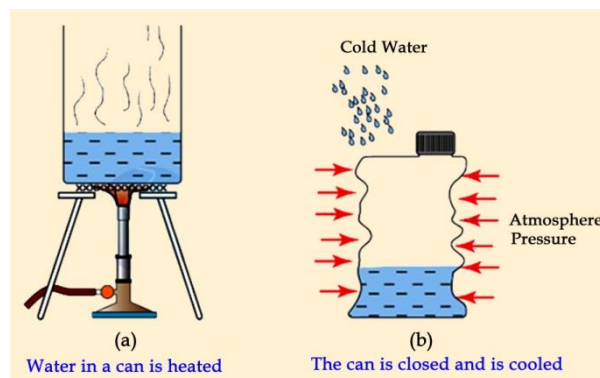

- (a) Compare the air pressure inside the can and outside the can in figure (a)
- (b) Compare the air pressure inside the can and outside the can in figure (b)
- (c) What will Anandi observe and why?



Q3. Rohan's tea was ready but he was doing the task of chopping vegetables. He wanted to drink tea only after completing his work but he also wanted have his tea hot.

- (a) Suggest at least one method using which he can keep his tea warm for a longer time period.
- (b) Which mode (s) of heat transfer is prevented by this method?



Q4. State True or False

- (a) At night, cool air from sea moves over the land and is known as Sea Breeze.
- (b) Water is a good conductor of heat.
- (c) In steel, heat is transferred by convection.

Q5. What decides direction of Wind? State it in terms of pressure.

.....

.....

.....

.....

Worksheet: 32 (Mode: Face to Face)

Learning Outcomes to be achieved:

Relates processes and phenomena with causes, e.g., wind speed with air pressure; crops grown with types of soil; depletion of water table with human activities, etc.

Q1. Why chimney is always made on the roof of the houses?

Q2. Ria has both light and dark coloured T-shirts in her wardrobe. She decides to go a park for a stroll on a hot summer morning. Suggest the most appropriate colour(s) to wear for a outing during summertime ?

Q3. Match the following:

Column 1	Column 2
(i) Conduction	(a)Iron _____
(ii) Electromagnet	(b)Steel _____
(iii) Insulator	(c)Mercury _____
(iv) Cooking utensils	(d)Copper _____
(v) Connecting wires	(e) Air _____

Q4. (i) People sitting around bon fire receive the warmth by which process of heat transfer?

(ii) In the same situation, relate the amount of heat received with the distance between source of heat and the receiver.

Q5. **Give one word answer :**

(a) Name an appliance that produces heat but is not based on heating effect of current. _____

(b) Name an appliance based on heating effect of electric current.

(c) Name a temporary magnet _____

© NCERT
not to be republished

Worksheet: 33 (Mode: Face to Face)

Learning Outcomes to be achieved:

Relates processes and phenomena with causes, e.g., wind speed with air pressure; crops grown with types of soil; depletion of water table with human activities, etc.

Q1. On a summer evening, Sudhir was playing in a playground near his house when he heard a rumble of thunder and saw a bright flash of lightning. The storm was getting stronger and bolder with each passing minute.

(a) Suggest a safe place for Sudhir - _____

(b) Will it be safe for Sudhir to take shelter under an open shed in the park? Give reason for your answer.

Q2. **Fill in the blanks to complete the paragraph**

Meteorologists use this device to find wind speed _____. It counts _____ to calculate the wind speed. The stronger the wind blows, _____ the device rotates. It is often seen placed in _____ and _____.

Q3. Thunderstorms occur frequently in Delhi from April to August. Enlist two essential climatic conditions of Delhi which causes thunderstorms to occur frequently.

.....
.....
.....
.....

Q4. Rita was studying direction of winds and amount of rainfall in the summer season using the map given below. However, after looking at the map she had a lot of queries.

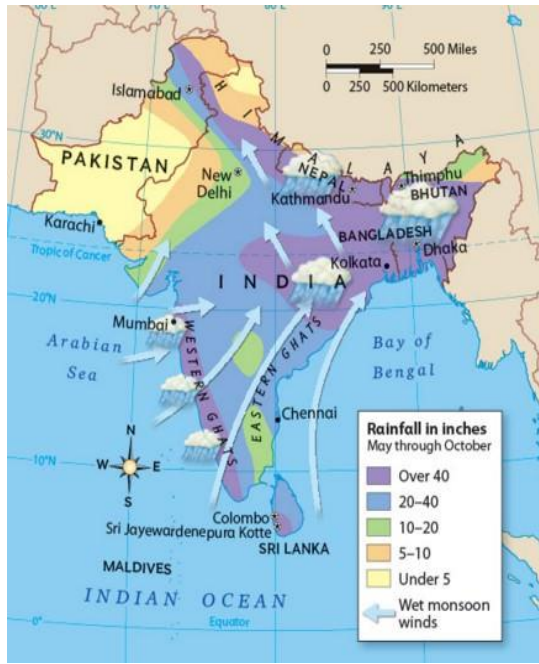

Help in solving her queries by answering the following questions:

(a) Identify the area(s) of high pressure on the map.

.....

(b) The direction of winds shown in the map will be equivalent to that of SEA BREEZE OR LAND BREEZE. Justify your answer.

.....

Q5. Match the following :

COLUMN 1	COLUMN 2
(i) Wind vane	Has an eye in the centre _____
(ii) Monsoon winds	Wind speed _____
(iii) Hurricane	Summer season _____
(iv) Anemometer	Tornado _____
(v) Twister	Wind direction _____

Worksheet: 34 (Mode: Online)

Learning Outcomes to be achieved:

Relates processes and phenomena with causes, e.g., wind speed with air pressure; crops grown with types of soil; depletion of water table with human activities, etc.

Q1.



When a balloon gets inflated then

- (a) Air pressure inside the balloon is more than the pressure of surroundings
- (b) Air pressure inside the balloon is less than the pressure of surroundings
- (c) Air pressure inside the balloon is equal to the pressure of surroundings
- (d) Atmospheric pressure always remains constant

Q2. Which of the following statements is true in the given situation?

A hot air balloon rises upwards because

- (a) The wind blowing in that area makes it rise up
- (b) The balloon is filled with hot air.
- (c) The air filled in the balloon is lighter than the surrounding air.
- (d) The air filled in the hot air balloon is hydrogen.

- (i) a, d and b
- (ii) a, b and c
- (iii) b, c and d
- (iv) b and c

Q3. Observe the pictures given below and choose the image in which hand of the person will receive maximum amount of heat?



a)



b)



c)



d)

- Q4. CFL's have been replaced by LED lights as
- (a) LED lights are energy efficient
 - (b) CFL's are harmful for the environment
 - (c) CFL's consume more electrical energy
 - (d) All of the above

Q5. Rita took a thin wire of the following materials and passed electric current through them one by one.

Which of these wires will begin to glow?

- (a) Nichrome (b) Tungsten (c) Copper (d) Aluminium

Worksheet: 35 (Mode: Online)

Learning Outcomes to be achieved:

Relates processes and phenomena with causes, e.g., wind speed with air pressure; crops grown with types of soil; depletion of water table with human activities, etc.

Q1. Observe the figure given below and identify the area of reduced air pressure.



- (a) near the mouth of the bottle
 - (b) inside the bottle
 - (c) middle of the bottle
 - (d) outside the bottle
- Q2. Select the incorrect one from the following statements?
- (a) Distance – time graph having straight line parallel time axis indicates constant speed.
 - (b) Speed- time graph for uniform motion is a straight line parallel to time axis.
 - (c) Distance –time graph for uniform motion is a straight line graph
 - (d) Speed – time graph having a straight line shows that the object covers unequal distances in equal interval of time
- Q3. Which of the following mirrors can be used as the side view mirror of a vehicle?
- (a) Diagram plane mirror
 - (b) Diagram of convex mirror
 - (c) Diagram of concave mirror
 - (d) Diagram of an arc without showing polish on any side
- Q4. Which of the following case a real image is formed?
- (a) Image formed by a plane mirror
 - (b) Image formed by a dentist's mirror while working.
 - (c) Image formed by a pin hole camera
 - (d) Image formed by a rear view mirror

Q5. Choose the **incorrect** statement?

- (a) The amount of heat energy radiated by a hot black object is maximum
- (b) All objects radiate heat energy
- (c) All objects absorb some amount of heat energy falling on them
- (d) The amount of heat energy absorbed by an object depends on its colour

© NCERT
not to be republished

Worksheet: 36 (Mode: Online)

Learning Outcomes to be achieved:

Relates processes and phenomena with causes, e.g., wind speed with air pressure; crops grown with types of soil; depletion of water table with human activities, etc.

- Q1. Name the process which causes the room heater to transfer its heat and thereby make the entire room warm.
- (a) Radiation
 - (b) Conduction
 - (c) Transmission
 - (d) Convection
- Q2. A chimney is always placed near the roof of the house because
- (a) Hot air exerts pressure
 - (b) Hot air rises up
 - (c) Temperature and speed of air is low
 - (d) Hot air is heavier
- Q3. In formation of a cyclone, a lot of heat is released in the atmosphere during the process of
- (a) Transpiration
 - (b) Condensation
 - (c) Evaporation
 - (d) Precipitation
- Q4. Thunderstorms are frequent in Delhi because it has
- (a) hot and humid climate
 - (b) cold and humid climate
 - (c) cold and dry climate
 - (d) hot and dry climate
- Q5. Which of the following statements indicate that air exerts pressure?
- (a) An umbrella gets upturned by high speed winds during a wind storm
 - (b) Smoke always rises up
 - (c) Flags flutter when wind is blowing
 - (d) A hot air balloon rises up
- Q6. Which component in a simple closed electric circuit causes flow of electrons :
- (a) connecting wires
 - (b) A bulb
 - (c) A battery
 - (d) A switch

- Q7. Air is an insulator but what causes it to become hot?
- (a) Transformation
 - (b) Convection
 - (c) Conduction
 - (d) Radiation
- Q8. A thermo flask is able to prevent heat transfer due to
- (a) conduction and convection
 - (b) convection and radiation
 - (c) conduction and radiation
 - (d) conduction, convection and radiation

© NCERT
not to be republished

Worksheet: 37 (Mode: ONLINE) (LO-6)

Learning Outcomes to be achieved:

Explains processes and phenomena with causes, e.g., wind speed with air pressure; crops grown with types of soil; depletion of water table with human activities, etc.

Q1. The steps followed in processing of fibre into wool can be represented as follows:

- a. Cleaning of burrs-Dyeing-rolling-Shearing-Scouring-Sorting
- b. Shearing-Scouring-Sorting-Cleaning of burrs-Dyeing-Rolling
- c. Cleaning of burrs-Shearing-rolling-Dyeing-Scouring-Sorting
- d. Shearing-Cleaning of burrs-Scouring-Sorting-Dyeing-Rolling

Q2. Trace the correct life stages of silk worm

- a. Male and female moth-eggs-pupa-caterpillar-cocoon-moth
- b. Male and female moth-eggs-moth-pupa-caterpillar-cocoon
- c. Male and female moth-eggs-cocoon-pupa-caterpillar-moth
- d. Male and female moth-eggs-caterpillar-pupa-cocoon-moth

Q3. The process of transfer of heat for which no medium is required is/are_

- a. Conduction
- b. Convection
- c. Radiation
- d. Radiation and convection

Q4. The reason why it is more comfortable to wear light colored clothes in summer and dark color clothes in winter is that

- a. Light and dark colors absorb equal amount of heat but they are more soothing to eyes according to the summer and winter respectively
- b. Light and dark colors absorb equal amount of heat but they are more comfortable to the body according to their fabric quality
- c. Light colors absorb less heat and dark colors absorb more heat
- d. Light colors absorb more heat and dark colors absorb less heat

- Q5. The respiratory organs which are like a small opening on the sides of the body, are
- Moist and slimy skin
 - Gills
 - Spiracles
 - Lungs
- Q6. While doing heavy exercise, anaerobic respiration takes place in our muscle cells. During this process, what is being produced?
- Alcohol and lactic acid
 - Lactic acid and CO_2
 - Alcohol and CO_2
 - Lactic acid only
- Q7. Which one is a continuous network of channels that transports water to the entire plant by connecting roots to the leaves through the stem and branches?
- Phloem
 - Xylem
 - Root hair
 - Tracheid
- Q8. Choose the correct sequence in terms of human excretory system
- Kidney-urethra-urinary bladder-ureter-urinary opening
 - Kidney-ureter-urinary bladder-urinary opening-urethra
 - Kidney-ureter-urinary bladder-urethra-urinary opening
 - Kidney-urinary bladder-ureter-urethra-urinary opening
- Q9. In making a battery
- Positive terminal of one cell is connected to the positive terminal of the other end
 - Negative terminal of one cell is connected to the negative terminal of the other end
 - Positive terminal of one cell is connected to the negative terminal of the other end
 - All the cells are tied together in a sequence with a wire irrespective of their terminals

Q10. When an electric current flow through an insulated copper wire AB as shown in the figure, the wire

- a. becomes red hot.
- b. deflects a magnetic needle placed near it.
- c. behaves like a fuse.
- d. gives electric shock.

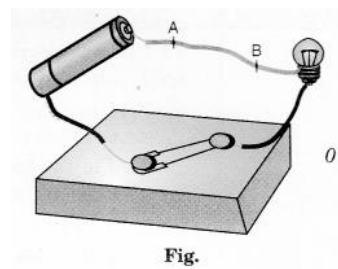

© NCERT
not to be republished

Worksheet: 38 (Mode: Face to Face) (LO-7)

Learning Outcomes to be achieved:

Writes word equation for chemical reactions, e.g., acid-base reactions; corrosion; photosynthesis; respiration, etc.

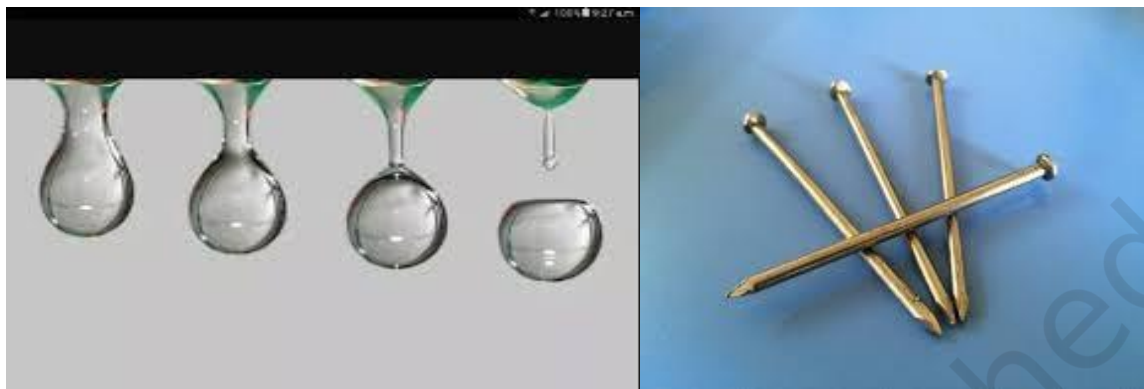

Q1. Imagine a situation where iron nails are kept in open contact with air and water drops keep falling on them.

(a) What will be your observation after a week?

.....
.....

(b) Write a word equation to show the above reaction.

.....
.....

Q2. Observe the picture in which magnesium ribbon is burning in air to produce white dazzling light. Write a word equation to show the above reaction.

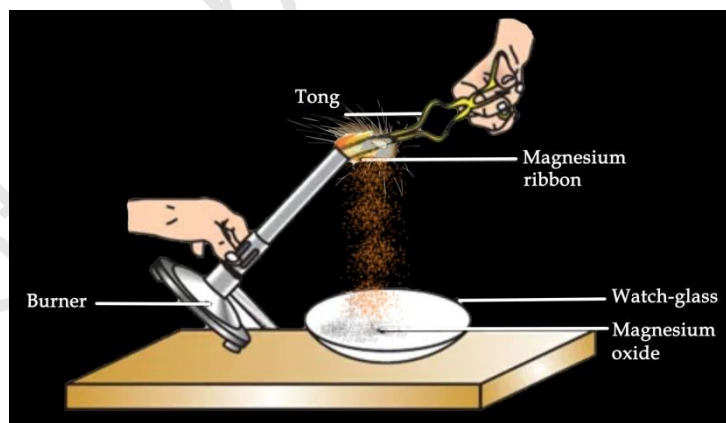

.....
.....

- Q3. **Let's save our Heritage. It's one of the Seven Wonders of the World!** Industries near Taj Mahal in Agra give out many harmful gases. One of them is sulphur dioxide. When it rains, sulphur dioxide dissolves in rain water and forms acid rain. Acid rain corrodes the marble of the monument. Write the word equation to show



Worksheet: 39 (Mode: Face to Face)

Learning Outcomes to be achieved:

Writes word equation for chemical reactions, e.g., acid-base reactions; corrosion; photosynthesis; respiration, etc.

- Write word equations for chemical reactions.
- Classify the two different types of respiration processes.
- Explain the difference between two different respiration processes.
- Apply learning of scientific concepts in day-to-day life.

After doing homework, Ruchi was tired and she had lunch in afternoon and started feeling energetic.

In the evening, as she was running fast in a playground, she experienced muscle cramps.

1. Ruchi had glucose in the form of food, what will be the word reaction involving the breakdown of glucose in the presence of oxygen?
2. What is the type of respiration which involves oxygen?
3. Why do you think Ruchi experienced muscle cramps?
4. Write the word reaction for breakdown of glucose in absence of oxygen?
5. What is the type of respiration which do not involve oxygen?

Worksheet: 40 (Mode: Face to Face)

Learning Outcomes to be achieved:

Writes word equation for chemical reactions, e.g., acid-base reactions; corrosion; photosynthesis; respiration, etc.

- writes word equation for the chemical reactions
- applies scientific concept in daily-to-day life

Ruchi is commuting to her school every day on her bicycle. One day she observed that the chain and handles of her bicycle, which are made of iron have destroyed. She could also see some brown flakes on handle and chain.



(a) Name the process responsible for the brown flakes.

.....

(b) Writes the word equation for the above process involved.

.....

(c) Suggest any preventive methods to Ruchi for the above process.

.....

1. (a) What will happen on exhaling air in the solution of lime water?

.....

2. (a) What will happen on exhaling air in the solution of lime water?

b) Write the word equation involved.

Worksheet: 41 (Mode: Online)

Learning Outcomes to be achieved:

Writes word equation for chemical reactions, e.g., acid-base reactions; corrosion; photosynthesis; respiration, etc.

Q1. Acid reacts with base to give salt and water.

Magnesium hydroxide + Hydrochloric acid \longrightarrow X + water

In the above equation X is

- a) acid b) base c) salt d) amphoteric

Q2. X + Sulphuric acid \longrightarrow Sodium Sulphate + Water

Identify the **X** from the above word equation

- a) Sodium Hydroxide
b) Sodium Chloride
c) Sodium Nitrate
d) Sodium Phosphate.

Q3. When a refined metal is converted into a more chemically stable form such as oxide, hydroxide, or sulfide naturally is called Corrosion where it gradually destructs materials (usually a metal) through chemical and/or electrochemical reaction with their environment.

Sodium + Oxygen \longrightarrow Sodium Oxide

The above process is called

- a) Neutralisation reaction
b) Corrosion
c) acid-base reaction
d) acid-acid reaction

Q4. Iron + moisture \longrightarrow hydrated iron oxide/ iron hydroxide

The above phenomenon is called

- a) Rusting b) neutralisation c) galvanisation d) acid -base reaction.

Q5.

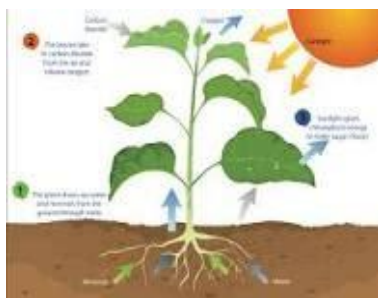

In the above photosynthesis process the following reactions take place.

Carbon dioxide + water + light \longrightarrow Glucose + **X**

In the above word equation the **X** is

a) Oxygen b) nitrogen c) hydrogen d) helium

Q6. Respiration is the biochemical process in which the cells of an organism obtain energy by combining oxygen and glucose, resulting in the release of carbon dioxide, water.

Glucose + oxygen \longrightarrow **X** + water

In the above respiration process word equation the symbol **X** is

a) oxygen b) nitrogen c) carbon dioxide d) fructose.

© NCERT
not to be republished

Worksheet: 42 (Mode: Online)

Learning Outcomes to be achieved:

Writes word equation for chemical reactions, e.g., acid-base reactions; corrosion; photosynthesis; respiration, etc.

Q1. Sonu took a teaspoonful of Vinegar in a test tube. She added a pinch of baking soda to it. She was excited to hear a hissing sound and to see bubbles of a gas coming out.

Choose the correct word equation to represent the above reaction-

- (a) Vinegar + Sodium Carbonate \rightarrow Carbon dioxide + other substances
- (b) Vinegar (Acetic Acid) + Baking Soda (Sodium hydrogen carbonate) \rightarrow Carbon dioxide + other substances
- (c) Vinegar + Baking Soda \rightarrow Hydrogen gas + other substances
- (d) Baking Soda + Sodium Carbonate \rightarrow Carbon dioxide + other substances

Worksheet: 43 (Mode: Online)

Learning Outcomes to be achieved:

Writes word equation for chemical reactions, e.g., acid-base reactions; corrosion; photosynthesis; respiration, etc.

Q1. Sonu took a teaspoonful of Vinegar in a test tube. She added a pinch of baking soda to it. She was excited to hear a hissing sound and to see bubbles of a gas coming out. She passed this gas through freshly prepared lime water.

Choose the correct word equation to represent the reaction of passing of gas formed through limewater.

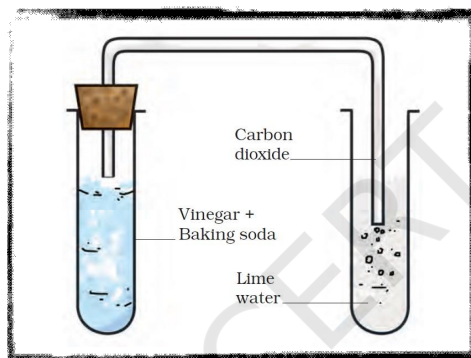

- (a) Hydrogen gas (H_2) + Calcium Carbonate ($CaCO_3$) \rightarrow Carbonic acid (H_2CO_3) + other substances
- (b) Vinegar (Acetic Acid) + Baking Soda (Sodium hydrogen carbonate) \rightarrow Carbon dioxide + other substances
- (c) Calcium Carbonate ($CaCO_3$) + Water (H_2O) \rightarrow Carbon dioxide (CO_2) + Lime water [$Ca(OH)_2$]
- (d) Carbon dioxide (CO_2) + Lime water [$Ca(OH)_2$] \rightarrow Calcium Carbonate ($CaCO_3$) + Water (H_2O)

Worksheet: 44 (Mode: Online)

Learning Outcomes to be achieved:

Writes word equation for chemical reactions, e.g., acid-base reactions; corrosion; photosynthesis; respiration, etc.

Q1. Rohan took 50 mL of water in a beaker and dissolved 5g of copper sulphate in it and stirred. He put a clean iron nail in this solution and kept the beaker undisturbed for some time. Slowly the blue colour of copper sulphate solution faded and iron got covered with red-brown layer of copper metal.



Rohan wrote down the word equation to represent the above reaction in his notebook. Choose the correct word equation he wrote-

- (a) Iron Sulphate solution (blue) + Copper \rightarrow Copper Sulphate solution (green) + Iron (brown deposit)
- (b) Copper Sulphate (blue) + Iron \rightarrow Iron Sulphate (green) + Copper (brown deposit)
- (c) Copper Sulphate solution (blue) + Iron \rightarrow Iron Sulphate solution (green) + Copper (brown deposit)
- (d) Copper Sulphate (blue) + Copper \rightarrow Iron Sulphate (green) + Iron (brown deposit)

Worksheet: 45 (Mode: Face to Face) (LO-8)

Learning Outcomes to be achieved:

Measures and calculates e.g., temperature; pulse rate; speed of moving objects; time periods of a simple pendulum, etc.

Q1. Using the graph given below, answer the questions that follow :

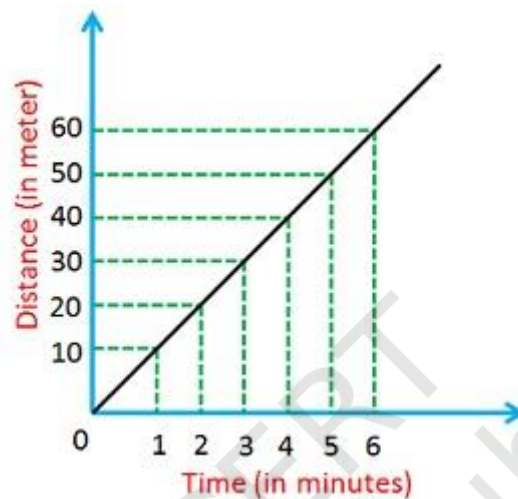

- (a) Calculate speed of the object between $t = 0$ to $t = 4$ minutes
- (b) Calculate speed of the object between $t = 4$ minutes to 6 minutes
- (c) What type of motion is exhibited by the object?

Q2. Anandi was jogging around a rectangular park with a constant speed of 20 m/s. If she takes one round in 10 minutes, calculate total distance covered by her in 1 round?

Q3. The odometer reading of a car is 254362 km. What will be the reading of odometer after the car covers a distance of 500 km?

Q4. Express (a) 108 km/h into m/s

Q5. Calculate speed of the car using the following table :

S.No	Odometer Reading(km)	Time (am)
1	254225 km	8:15 am
2	254249 km	8:45 am

Worksheet: 46 (Mode: Face to Face)

Learning Outcomes to be achieved:

Measures and calculates e.g., temperature; pulse rate; speed of moving objects; time periods of a simple pendulum, etc.

- Q1. A snail covers a distance from point A to point B in 2 minutes and 20 seconds. Measure this distance between these points and calculate speed of the snail in cm/s

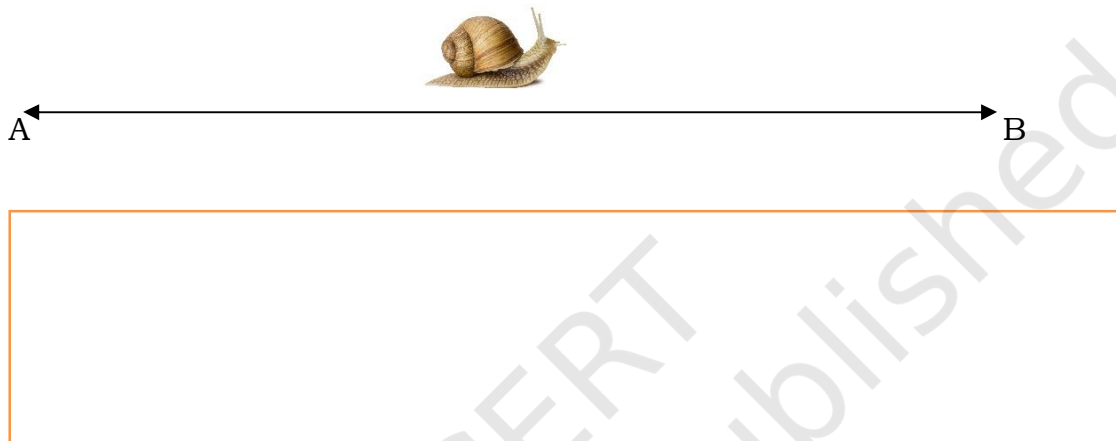

- Q2. Calculate time period of the simple pendulum if the bob travels from position A to position B in 0.2 seconds.

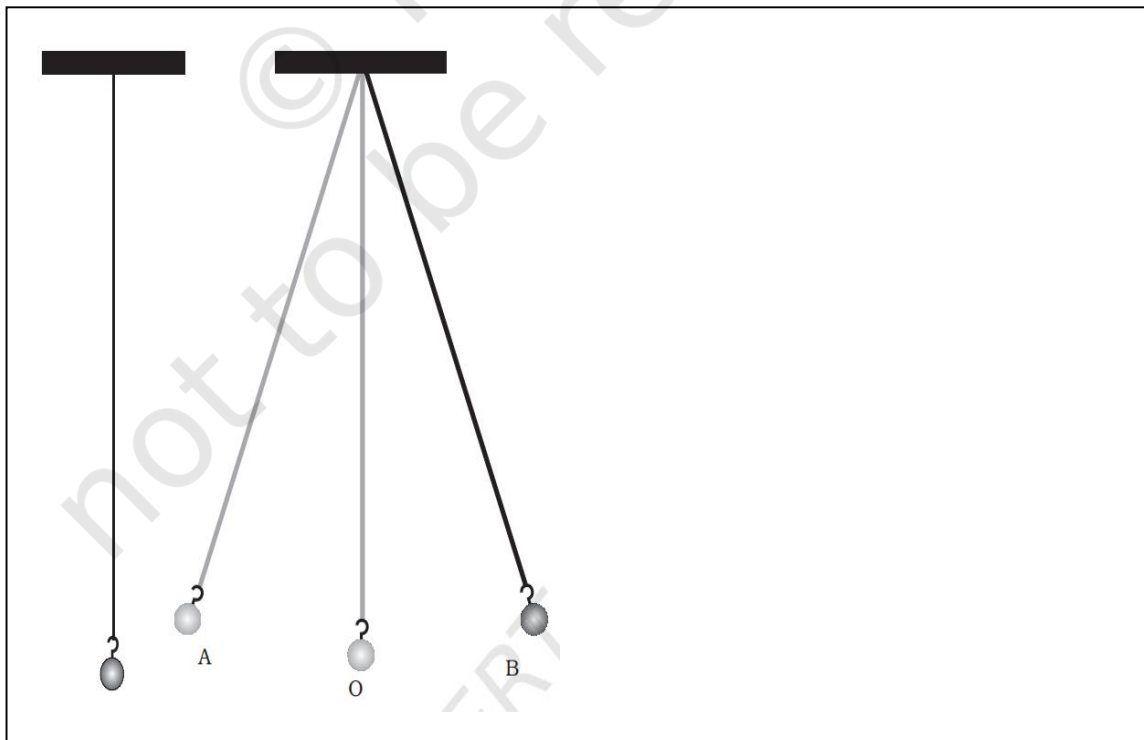

Q3. How much time will the simple pendulum in the above question take to complete 50 oscillations?

Q4. Rahul took part in a 100m race and asked his friend to measure his timing using a stopwatch. Calculate Rahul's speed during the race using the diagram given below.

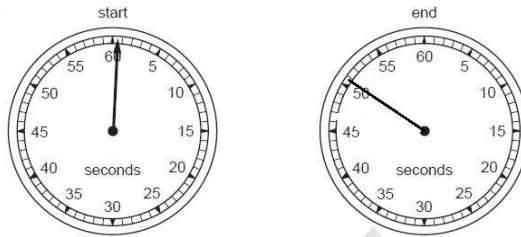

Q5. (a) Measure the reading of the thermometer given below and identify it.

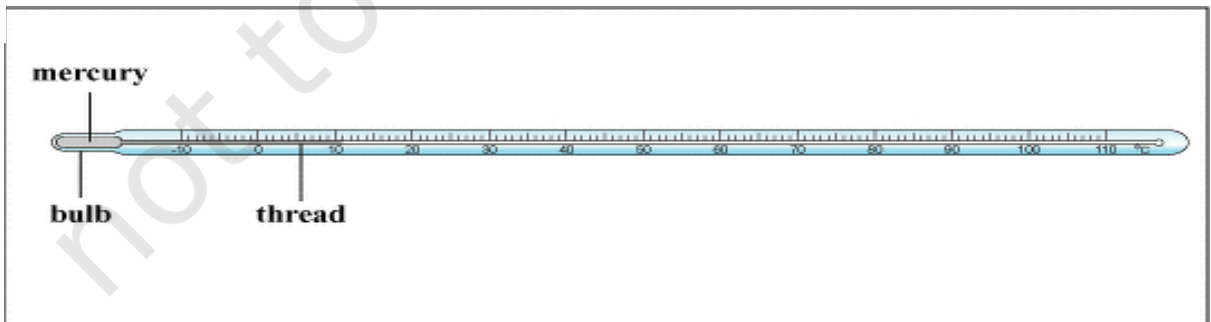

.....

(b) Calculate the value of each small division of the given thermometer.

.....

Worksheet: 47 (Mode: Face to Face)

Learning Outcomes to be achieved:

Measures and calculates e.g., temperature; pulse rate; speed of moving objects; time periods of a simple pendulum, etc.

- Q1. Calculate total battery voltage of the arrangement shown below, if voltage of each cell is 2.5 V.

- Q2. Ritesh was cycling around a circular field with the speed of 22m/s. He completes one round of the circular field in 2 minutes and 30 seconds. Calculate (a) Total distance covered by him in one round (ii) Radius of the circular field.

- Q3. Calculate focal length of the concave mirror using the diagram given below :

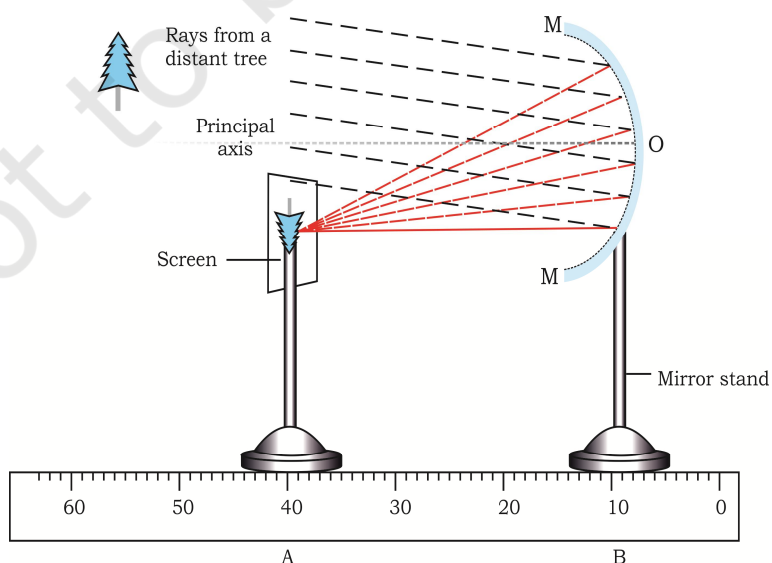

Q4. What is boiling temperature of water? Calculate its value in Fahrenheit.

Q6. Rohan was feeling feverish and used a mercury based thermometer to determine his body temperature. Help him decide whether he has fever or not by measuring his body temperature using the diagram given below.

Fahrenheit clinical thermometer



Worksheet: 48 (Mode: Face to Face)

Learning Outcomes to be achieved:

Measures and calculates e.g., temperature; pulse rate; speed of moving objects; time periods of a simple pendulum, etc.

Set up a simple pendulum as shown in the figure with a thread of length nearly one metre hanging from a rigid support. Let the bob of the pendulum come to rest at its mean position. Mark the mean position (O) of the bob on the floor below it or on the wall behind it.

To measure the time period of the pendulum we need a stopwatch (the stopwatch of a mobile phone may also be used for the purpose). To set the pendulum in motion, gently hold the bob and move it slightly to one side (say A). Now release the bob from its displaced position (A). Remember that bob should not be pushed but just released.

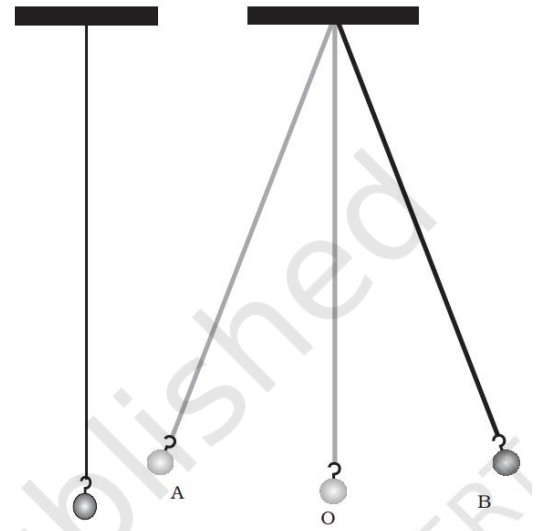

Start the stopwatch when the pendulum is at its mean position, O. Measure the time taken by pendulum to complete 20 oscillations (say). Record your observation. Repeat this activity 5 times.

S. No.	Time taken for 20 oscillations (s)	Time period (time taken in one oscillation) (s)

Divide the total time taken for 20 oscillations by 20; this will give the time period for the pendulum.

Worksheet: 49 (Mode: Online)

Learning Outcomes to be achieved:

Measures and calculates e.g., temperature; pulse rate; speed of moving objects; time periods of a simple pendulum, etc.

Q1. What is the speed of an object which is covering a distance of 50 km in every 30 minutes?

- (a) 1.67 km/h (b) 100 km/h (c) 25 km/h (d) 20 km/h

Q2. Aditi is learning to use laboratory thermometer as shown below. Help her to measure the minimum and maximum value of the temperature that can be measured by this thermometer.

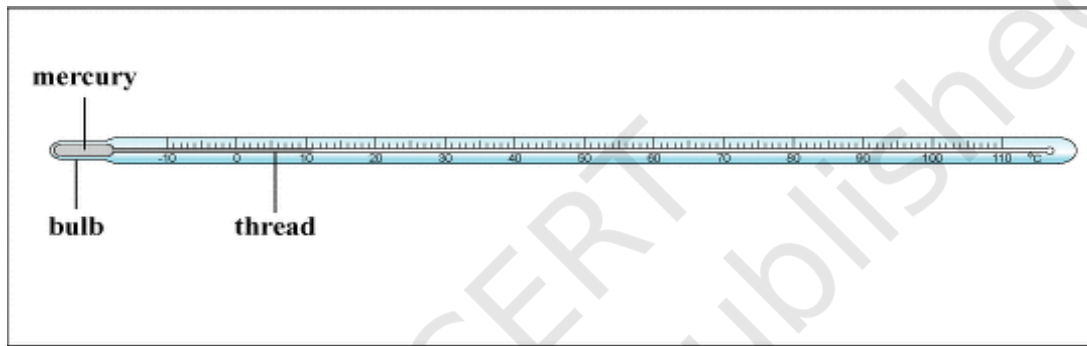

- (a) 110°C, 10°C
(b) 10°C, 100°C
(c) -10°C, 110°C
(d) 110°C, -10°C

Q3. Use the data given below, calculate and name the fastest car?

Name of the Car	Distance covered	Time taken
A	180 km	2 hours
B	45 km	15 minutes
C	30 m	2 seconds
D	36 km	30 minutes

- (a) A (b) B (c) C (d) D

Q4. Every day, Neeraj covers a distance of 4 km on his bicycle to reach school. In the afternoon he returns back home following the same route. Calculate total distance covered by him in five days to attend his school.

- (a) 40 km (b) 80 km (c) 20 km (d) 50 km

Q5. Calculate the speed of the car using the graph given below :

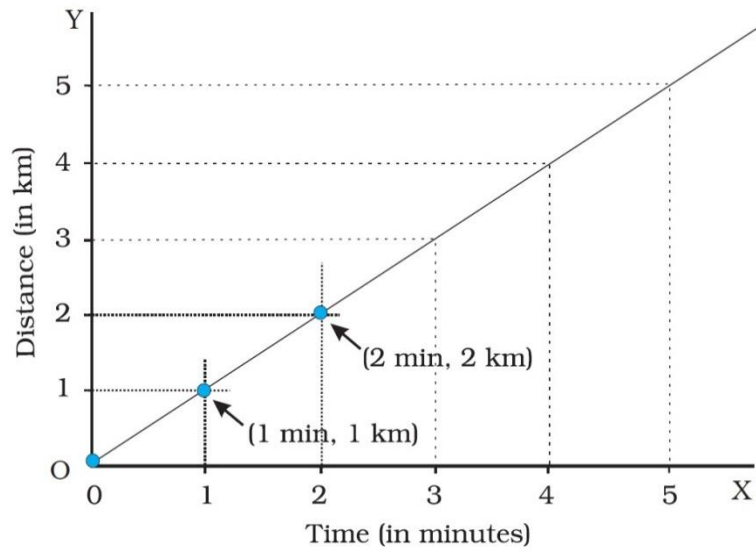

- (a) 4 km/min (b) 3 km/min (c) 2 km/min (d) 1 km/min

Worksheet: 50 (Mode: Online)

Learning Outcomes to be achieved:

Measures and calculates e.g., temperature; pulse rate; speed of moving objects; time periods of a simple pendulum, etc.

- Q1. If time period of a simple pendulum is 40 seconds then it implies that the pendulum will complete
- (a) 160 oscillations in 4 seconds
 - (b) 4 oscillations in 160 seconds
 - (c) 5 oscillations in 120 seconds
 - (d) 120 oscillations in 5 seconds
- Q2. Measurement of temperature of hot water can be done using
- (a) Clinical thermometer
 - (b) Maximum and Minimum thermometer
 - (c) Digital thermometer
 - (d) Laboratory thermometer
- Q3. Convert 40°C to Fahrenheit
- (a) 104°F
 - (b) 103°F
 - (c) 102°F
 - (d) 101°F
- Q4. An object moving around a circular track of radius 3.5 m completes its one round in 10 minutes. Calculate its speed in m/minutes
- (a) 1.1 m/min
 - (b) 2.2 m/min
 - (c) 3.3 m/min
 - (d) 4.4 m/min
- Q5. Calculate the distance covered by a bullet train travelling with the speed of 360 km/h in 10 minutes?
- (a) 3600 km
 - (b) 3.6 km
 - (c) $1/36$ km
 - (d) 60 km
- Q6. A plane mirror is placed at a distance of 20 cm from an object. What will be the distance between the object and its image?
- (a) 10 cm
 - (b) 20 cm
 - (c) 40 cm
 - (d) 30 cm
- Q7. At time $t_1 = 9:10$ am, a simple pendulum begins its oscillations. At time $t_2 = 9:30$ am, the simple pendulum completes 40 oscillations
- How many oscillations will the pendulum complete in a minute?

- (a) 2 oscillations
- (b) 4 oscillations
- (c) 5 oscillations
- (d) 3 oscillations

Q8. Calculate difference in temperature using the following diagram

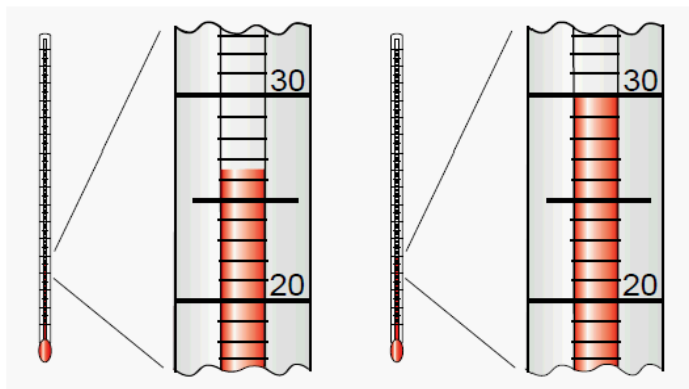

(a) 4°C

(b) 3°C

(c) 5°C

(d) 9.5°C

© NCERT
not to be republished

Worksheet: 51 (Mode: Face to Face) (LO-9)

Learning Outcomes to be achieved:

Draws labelled diagrams/ flow charts e.g., organ systems in humans and plants; electric circuits; experimental set ups; life cycle of silk moth, etc.

Q1. LABELLED THE FOLLOWING PARTS OF HUMAN DIGESTIVE SYSTEM:

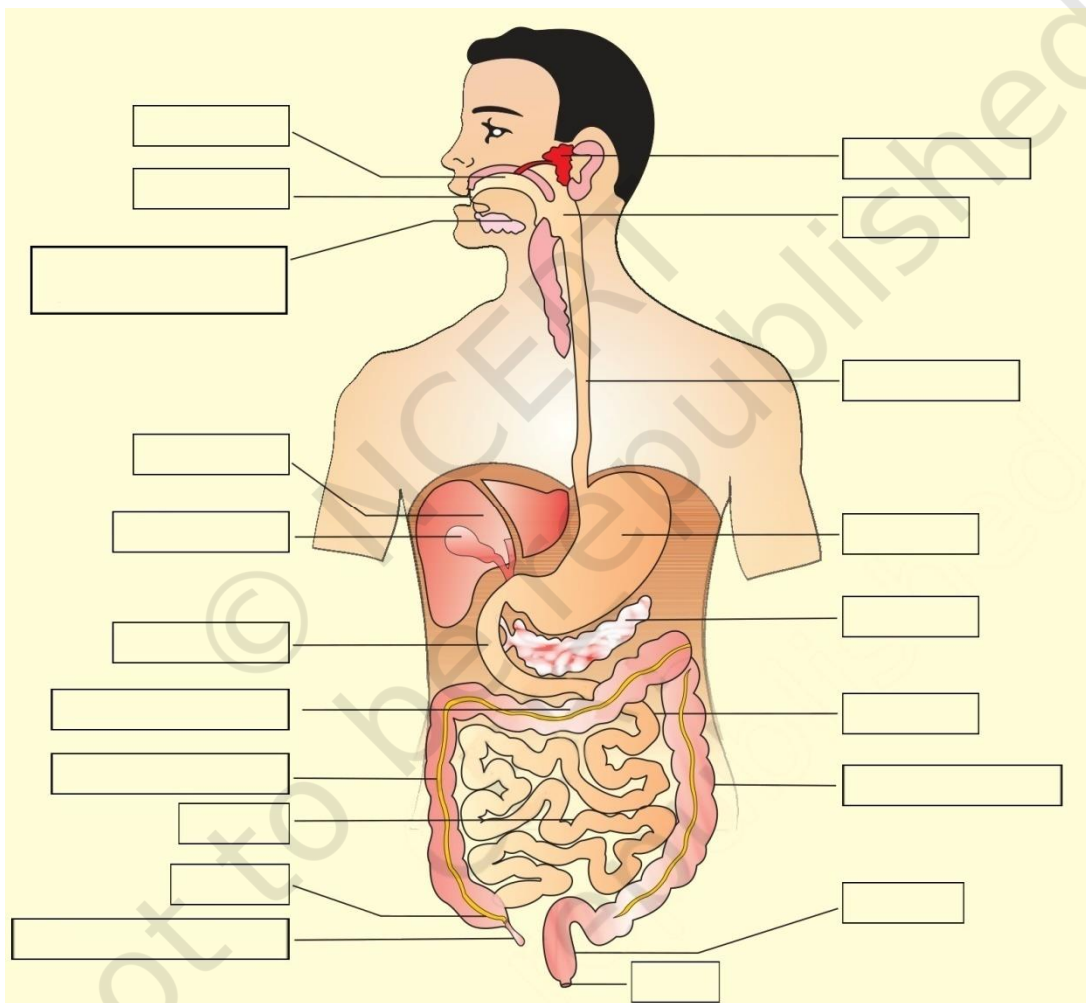

HUMAN DIGESTIVE SYSTEM

Q2. Look at the following flow chart and answer the following questions:

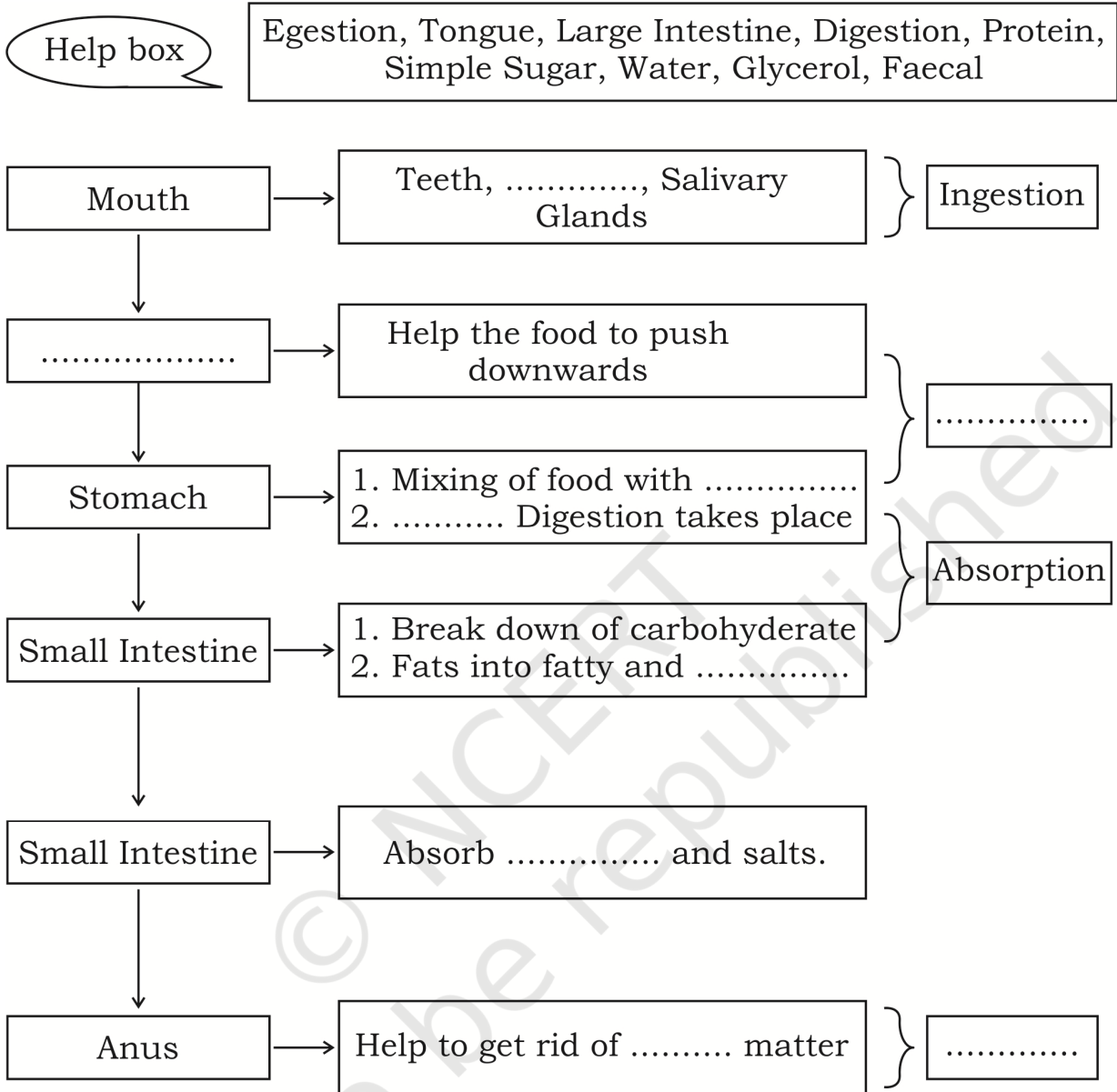

Worksheet: 52 (Mode: Face to Face)

Learning Outcomes to be achieved:

Draws labelled diagrams/ flow charts e.g., organ systems in humans and plants; electric circuits; experimental set ups; life cycle of silk moth, etc.

Q1. Mohit is provided with 3 substances. Help him decide the names of the various indicators with which he can differentiate between Acid, Bases and Salt.

CONCEPT MAP FOR 'ACIDS, BASES AND SALTS'

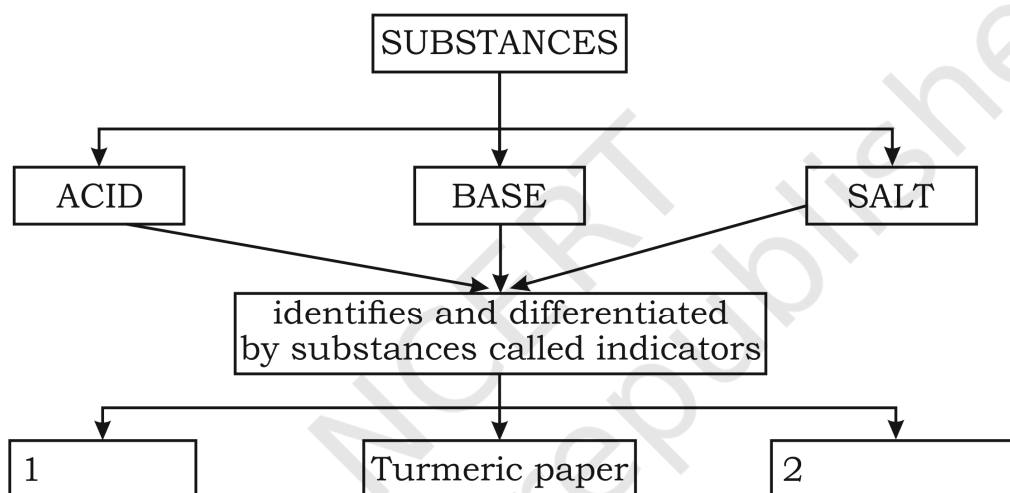

- (a) (i) Litmus Paper (ii) China Rose Petals
(b) (i) Blue Paper (ii) Red Paper
(c) (i) Turmeric Paper (ii) Red Chili Paper
(d) (i) Filter Paper (ii) Red cabbage Juice

Worksheet: 53 (Mode: Face to Face)

Learning Outcomes to be achieved:

Draws labelled diagrams/ flow charts e.g., organ systems in humans and plants; electric circuits; experimental set ups; life cycle of silk moth, etc.

Q1. Lovely learnt about physical and chemical changes. She performed few activities with her classmates and found out how to classify the changes in materials into physical and chemical changes. After her laboratory visit she made a flow chart to summarize her findings-

CONCEPT MAP FOR 'PHYSICAL AND CHEMICAL CHANGES'

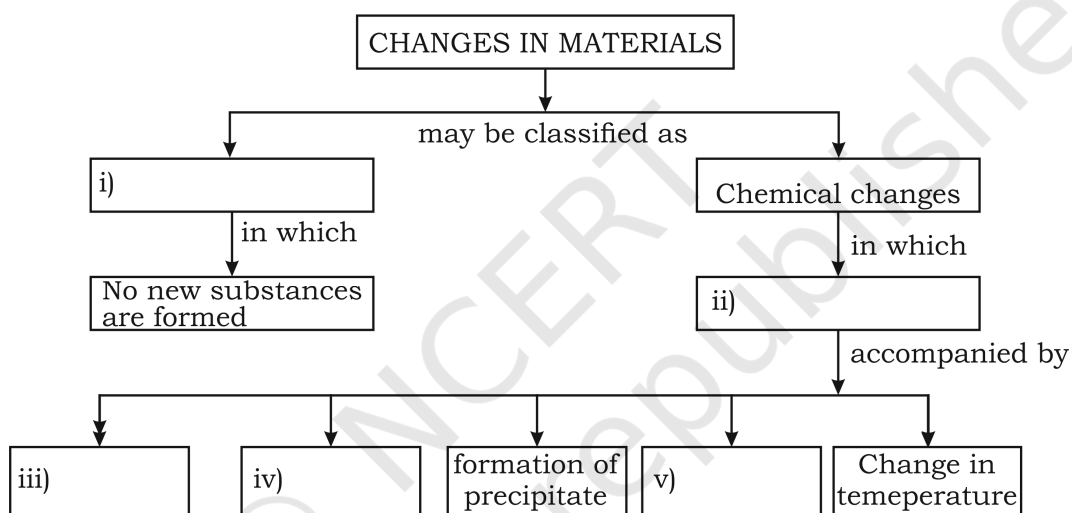

Worksheet: 54 (Mode: Face to Face)

Learning Outcomes to be achieved:

Draws labelled diagrams/ flow charts e.g., organ systems in humans and plants; electric circuits; experimental set ups; life cycle of silk moth, etc.

Q1. Fill in the given concept map from the words given in the box-

Base	Red	Bitter
Pink	Base	Sour

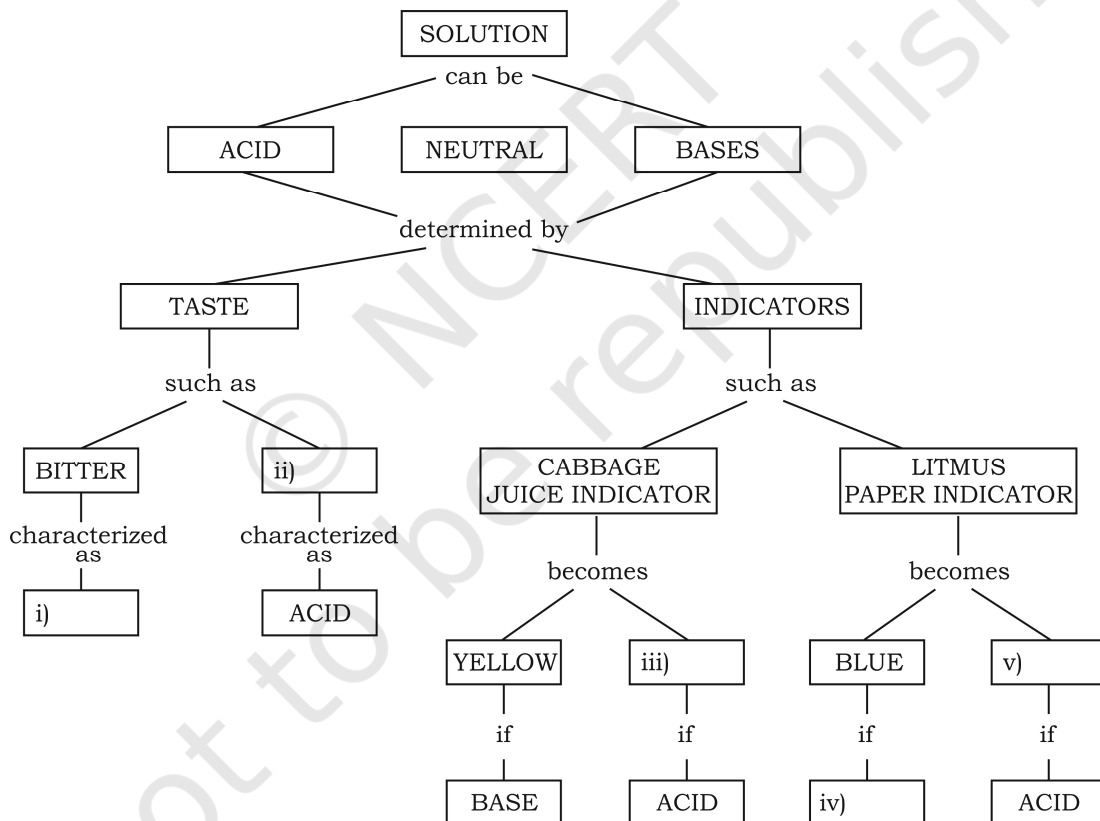

Worksheet: 55 (Mode: Face to Face)

Learning Outcomes to be achieved:

Draws labelled diagrams/ flow charts e.g., organ systems in humans and plants; electric circuits; experimental set ups; life cycle of silk moth, etc.

- **Discuss and appreciate scientific discoveries.**
- **Match the different life stages of silk moth to its life stages.**
- **Draw a schematic diagram of life cycle of silk moth.**
- **Collect information about the discovery of silk.**

A, B and C are the different life stages of a silk moth. The silk yarn is obtained from B of a silk moth. A is obtained when the laid eggs by female silk moth are hatched. At stage C, it weaves a net to hold itself.

Q1. Match the following to the corresponding-

Serial Number	Life stages	Name of the life stages
1	A	Cocoon
2	B	Pupa
3	C	Caterpillar

Q2. After matching the above, draw a life cycle of silk moth including above life stages.

Q3. Which country leads the world in silk production?

Q4. What is 'Silk route'?

Worksheet: 56 (Mode: Online)

Learning Outcomes to be achieved:

Draws labelled diagrams/ flow charts e.g., organ systems in humans and plants; electric circuits; experimental set ups; life cycle of silk moth, etc.

Q1. Observe the given diagrams and answer the following Question :

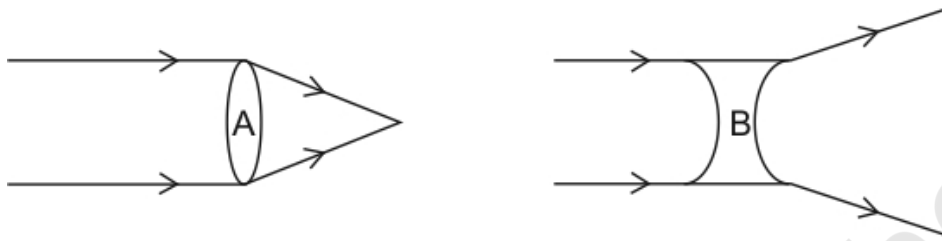

Label the lenses A and B

Q2. Observe the given diagrams and assign correct labels to each of them. Also give a suitable title to the diagrams given below.

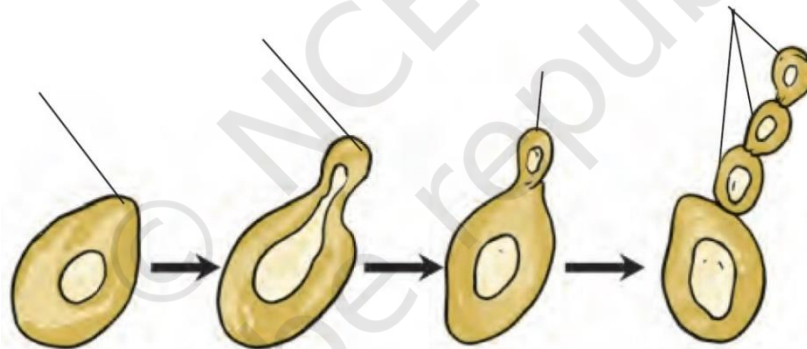

Q3. Complete the given flow chart on different methods of asexual reproduction

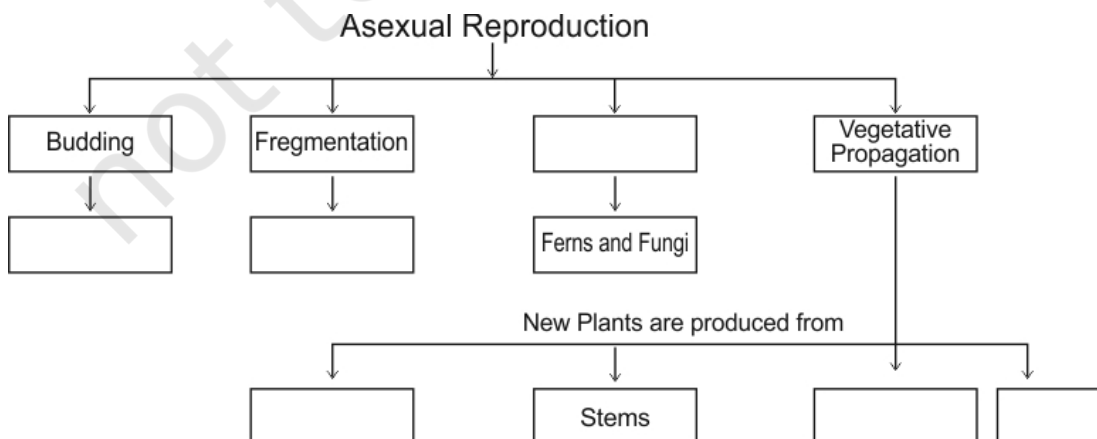

Q4.

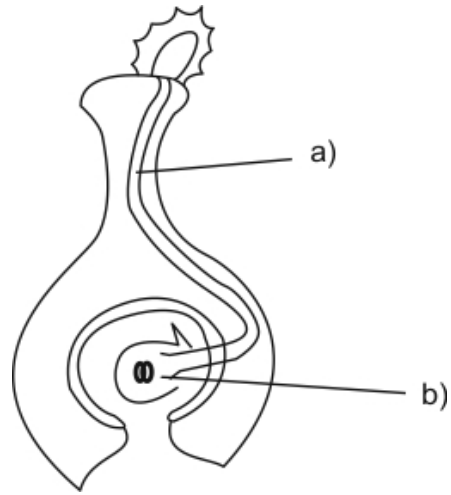

In the figure given above label a) and b) appropriately

Q5. Given below is the schematic diagram of circulation. Table Pulmonary artery, Pulmonary vein, Artery and Vein in it.

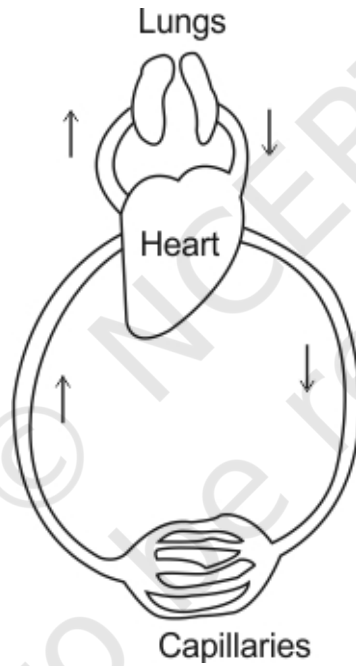

Worksheet: 57 (Mode: Online)

Learning Outcomes to be achieved:

Draws labelled diagrams/ flow charts e.g., organ systems in humans and plants; electric circuits; experimental set ups; life cycle of silk moth, etc.

1. Mohit is provided with 3 substances. Help him decide the names of the various indicators with which he can differentiate between Acid, Bases and Salt.

CONCEPT MAP FOR 'ACIDS, BASES AND SALTS'

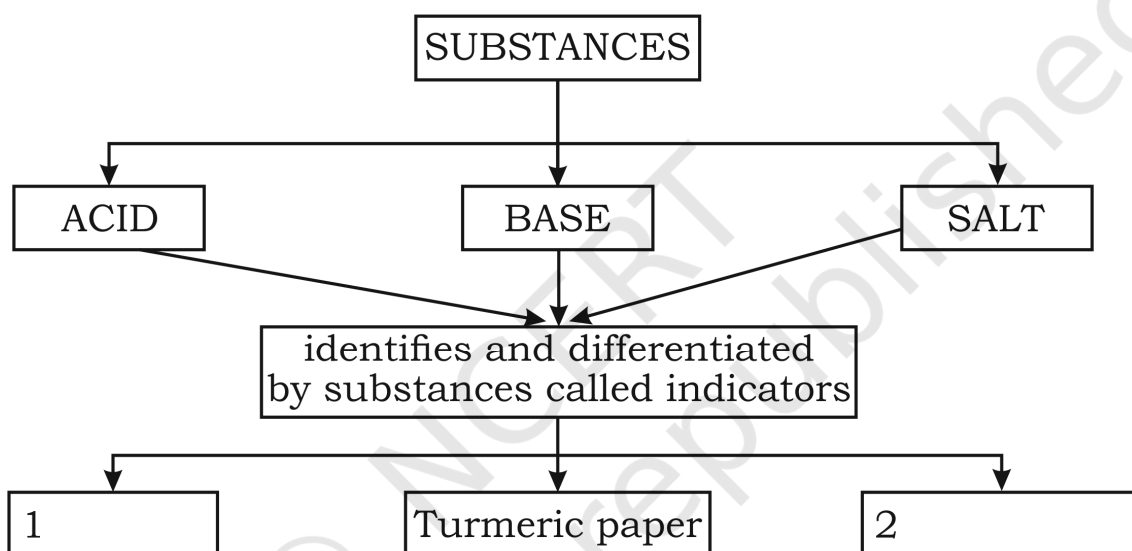

- (e) (i) Litmus Paper (ii) China Rose Petals
(f) (i) Blue Paper (ii) Red Paper
(g) (i) Turmeric Paper (ii) Red Chili Paper
(h) (i) Filter Paper (ii) Red cabbage Juice

Worksheet: 58 (Mode: Online)

Learning Outcomes to be achieved:

Draws labelled diagrams/ flow charts e.g., organ systems in humans and plants; electric circuits; experimental set ups; life cycle of silk moth, etc.

1. Lovely learnt about physical and chemical changes. She performed few activities with her classmates and found out how to classify the changes in materials into physical and chemical changes. After her laboratory visit she made a flow chart to summarize her findings. Fill up the blank boxes in her flow chart.

CONCEPT MAP FOR 'PHYSICAL AND CHEMICAL CHANGES'

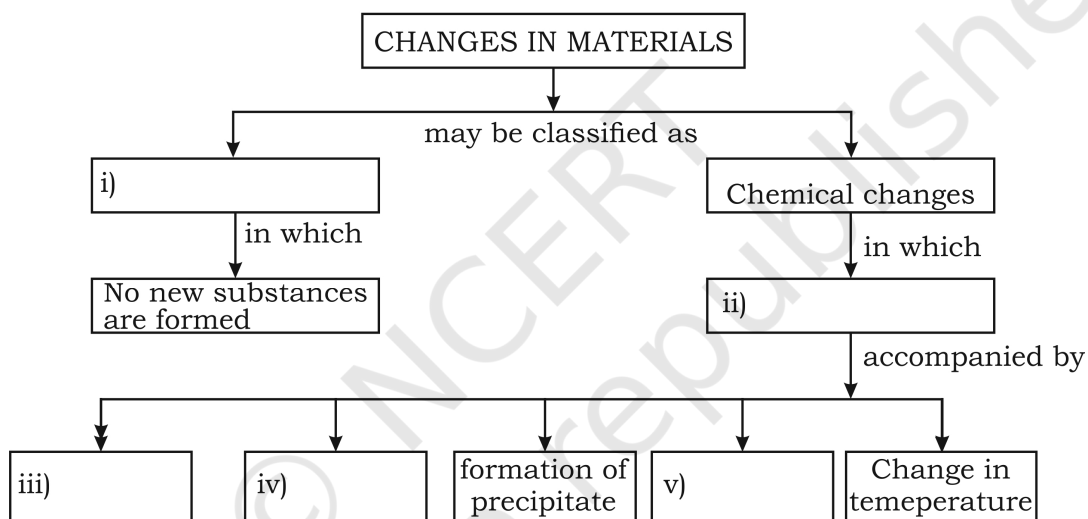

- (a) (i) Physical Changes (ii) New Substances are formed (iii) Change in colour (iv) Change in State (v) Evolution of Gas
- (b) (i) Chemical Changes (ii) No New Substances are formed (iii) Change in temperature (iv) Change in State (v) Evolution of Gas
- (c) (i) Physical Changes (ii) No New Substances are formed (iii) No change in colour (iv) Change in State (v) Evolution of Gas
- (d) (i) Physical Changes (ii) New Substances are formed (iii) Change in colour (iv) Change in State (v) No evolution of Gas

Worksheet: 59 (Mode: Online)

Learning Outcomes to be achieved:

Draws labelled diagrams/ flow charts e.g., organ systems in humans and plants; electric circuits; experimental set ups; life cycle of silk moth, etc.

Q1. Amy was playing with a small piece of glass. She was able to focus sunlight using this. Which of the following will correctly represent this object?



Q2. Four students measured temperature of hot water using a lab thermometer. They kept the thermometer as shown in the diagrams below.

Which student has measured the temperature correctly?

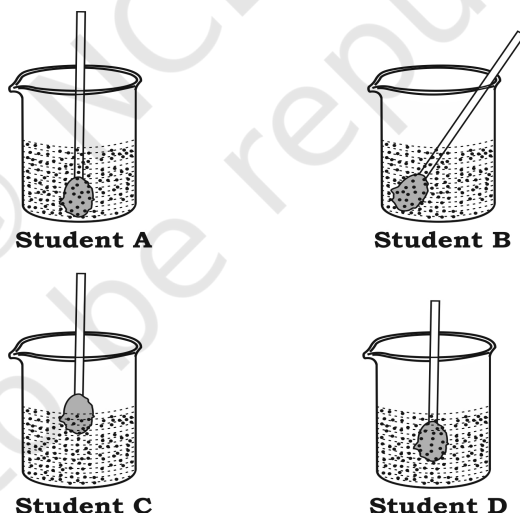

- (a) Student A
- (b) Student B
- (c) Student V
- (d) Student D

Q3. Observe the diagram given below and identify the error in the circuit due to which the bulb is not glowing.

Q4.

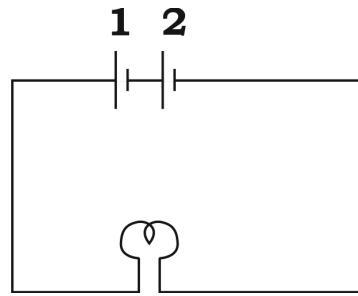

- (a) Absence of a key in the circuit
- (b) Connection between the bulb and positive terminal of the cell
- (c) Connection between negative terminal of cell1 and Cell 2
- (d) Gap between positive and negative terminals of each cell.

Q5. Choose the circuit in which the bulb will glow.

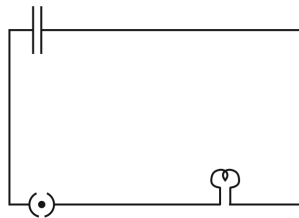

(a) Circuit A

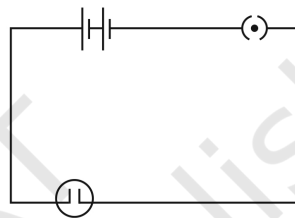

(b) Circuit B

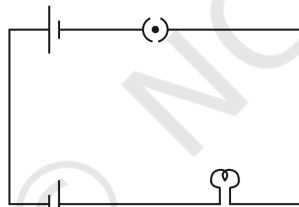

(c) Circuit C

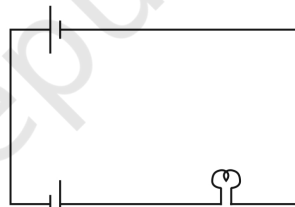

(d) Circuit D

Q6. Which of the two electric circuits are similar?

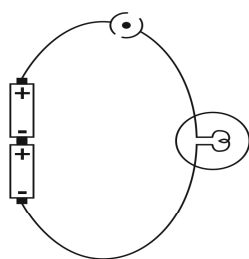

Circuit A

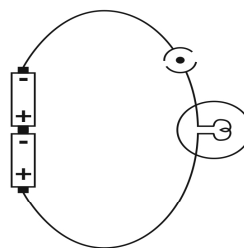

Circuit B

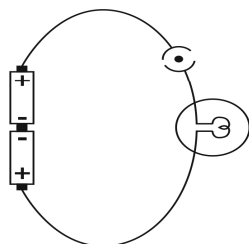

Circuit C

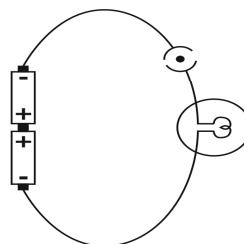

Circuit D

- (a) Circuit A and D
- (b) Circuit A and B
- (c) Circuit C and B
- (d) Circuit C and D

© NCERT
not to be republished

Worksheet: 60 (Mode: Online)

Learning Outcomes to be achieved:

Draws labelled diagrams/ flow charts e.g., organ systems in humans and plants; electric circuits; experimental set ups; life cycle of silk moth, etc.

Q1. The brightness of the bulb will be maximum in which circuit, if each cell has same voltage supply.

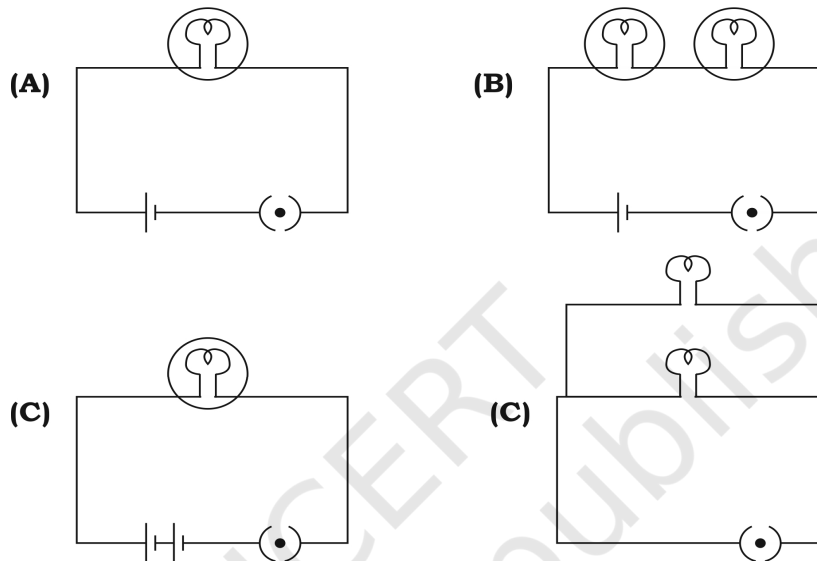

Q2. Which of the following diagram of an electric bell is correct?

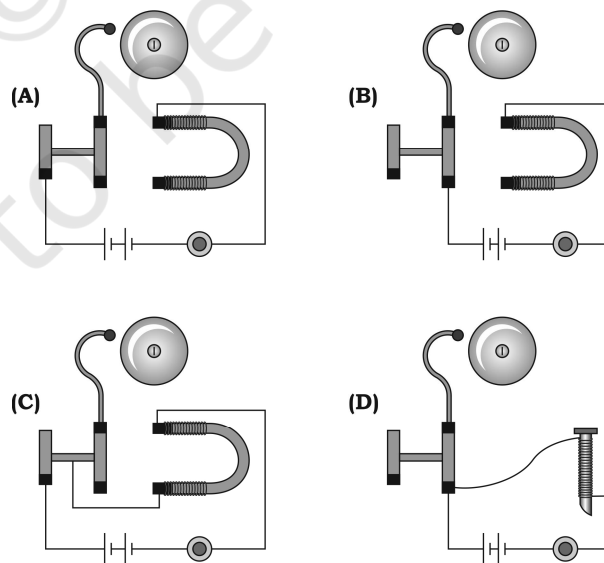

Q3. Using the diagram given below, what is the nature of the image?



Q4. Some articles such as steel spoon, plastic scales, pencil and a metallic divider are placed in a beaker containing hot water for few minutes. Which of them will become hot after few minutes?



- (a) pencil and metallic divider
- (b) Plastic scale and steel spoon
- (c) Pencil and plastic scale
- (d) steel spoon and metallic divider

Q5. Using the figures given below, identify the mirror and the lens respectively.

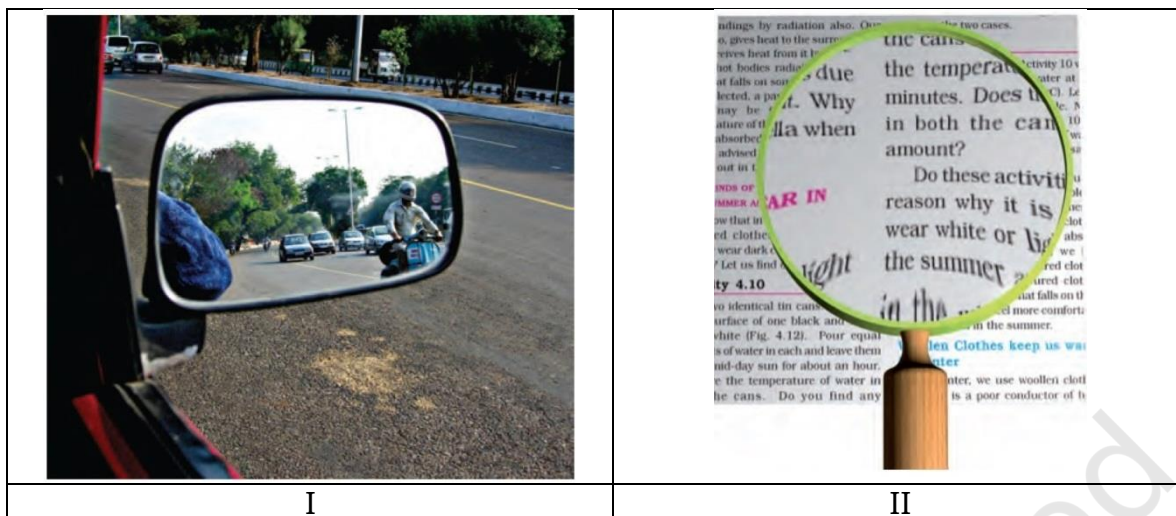

- (a) Convex mirror and concave lens
- (b) Convex mirror and Convex lens
- (c) Concave mirror and Convex lens
- (d) Concave mirror and Concave lens

© NCERT not to be republished

Worksheet: 61 (Mode: Face to Face) (LO-10)

Learning Outcomes to be achieved:

Plots and interprets graphs e.g. distance time graph.

Position vs. Timetable for a car is given below

Position vs. Time Table for a Car	
Time (Sec.)	Position (m)
0	0
1.0	5.0
2.0	10.0
3.0	15.0
4.0	20.0

Q1. Plot a distance –time graph for the information given above. Plot time along X- axis and distance along Y axis.

Q2. Scale chosen of X-axis= 1 unit= sec
Scale for Y-axis= 1 unit m

Q3. Seeing at the shape of the graph, which type of motion the body is having?
.....
.....

Q4. From the graph plotted, find the distance covered by the body in 2.5 seconds
.....
.....

Q5. (1)How much is the total distance travelled by the car in 4 seconds
.....
.....

(2) Find the total speed of the body in 4seconds

$$\text{Speed} = \frac{\text{Distance}}{\text{Time}} = \dots\dots\dots = \text{ m/s}$$

© NCERT
not to be republished

Worksheet: 62 (Mode: Face to Face)

Learning Outcomes to be achieved:

Plots and interprets graphs e.g. distance time graph.

Consider the graph above. The graph shows the movement of a car from point A. There are two slant lines AB and CD. The slant lines indicate that the car is moving. The flat line BC indicates that the car has stopped or is at rest.

Q1. One square on the horizontal axis represents=

One square on the vertical axis represents=

Q2. Calculate the distance travelled in first 10 seconds.

.....
.....

Q3. Speed of the car in first 10 seconds=

Q4. For how long did the car stop?

.....
.....

Q5. On what part of the journey did the car travel faster?

.....
.....

© NCERT not to be republished

Worksheet: 63 (Mode: Face to Face)

Learning Outcomes to be achieved:

Plots and interprets graphs e.g. distance time graph.

Task: To plot a graph for a given set of data choosing proper scales and to interpret them.

Representation of experimental data in graphical form helps in interpreting, communicating and understanding of the interdependence between the parameters associated with the observation. Graphical form (graphs) also provides a useful tool to communicate a given data in pictorial form helping us in verifying a given relation or to infer inter-relationships between the variables.

Radha happens to ride on a four-wheeler from her home to her friend's home. Following table gives her position at different times.

Time (min.)	0	5	10	15	20	25	30	35	40	45	50	55	60	65	70	75	80
Position (km)	0	1	2	2	3	4	5	6	7	8	9	10	10	11	12	13	14

Draw the position–time graph for the journey.

Using the graph, find the speed of the vehicle during 0 – 1200 s;

and during 0 – 4800 s.

Is it uniform?

Find the position of Radha at $t = 32$ min.

Worksheet: 64 (Mode: Online)

Learning Outcomes to be achieved:

Plots and interprets graphs e.g. distance time graph.

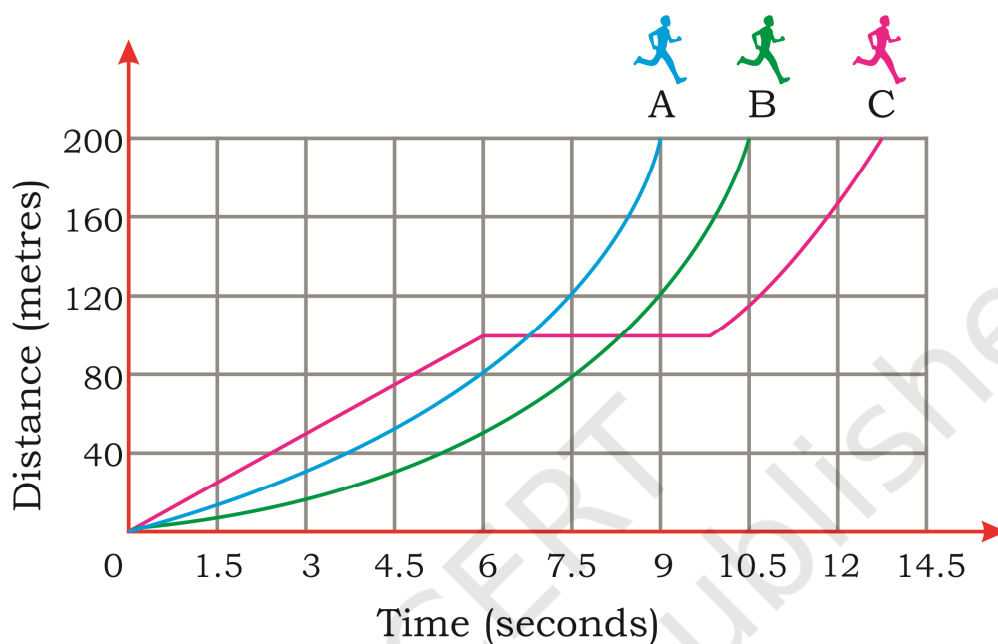

- Q1. In the distance-time graph shown, three lines represent the motion of three different students of Class 7 in a sports event(200m race) Radha's, Seeta's and Asha's journey is depicted by A, B and C line respectively. Whom do you think must have won the race?
- Radha
 - Seeta
 - Asha
 - All were winners.
- Q2. Out of three students which child took rest in between the race and how much was the discovered by her that child before taking rest:
- Asha and distance covered is 100m
 - Seeta and distance covered is 100m
 - Asha and distance covered is 120m
 - Seeta and distance covered is 120m
- Q3. The distance covered by Seeta in 9 seconds
- 160 m
 - 80m
 - 100m
 - 120 m

Q4. The time at which Radha covered 200m is

- (a) 9 sec
- (b) 12.5 sec
- (c) 10.5 sec
- (d) 14.5 sec

Q5. One square on the horizontal axis and on vertical axis represents

- (a) 1.5 seconds and 80 m respectively
- (b) 40m and 1.5 seconds respectively
- (c) 3seconds and 40 m respectively
- (d) 1.5 seconds and 40m respectively.

© NCERT
not to be republished

Worksheet: 65 (Mode: Online)

Learning Outcomes to be achieved:

Plots and interprets graphs e.g. distance time graph.

LO-23: Plots and Interprets Graphs e.g., distance time graph Learning Outcomes

Q1. The graph given below shows the motion of four runners P, Q, R and S in a 5km marathon.

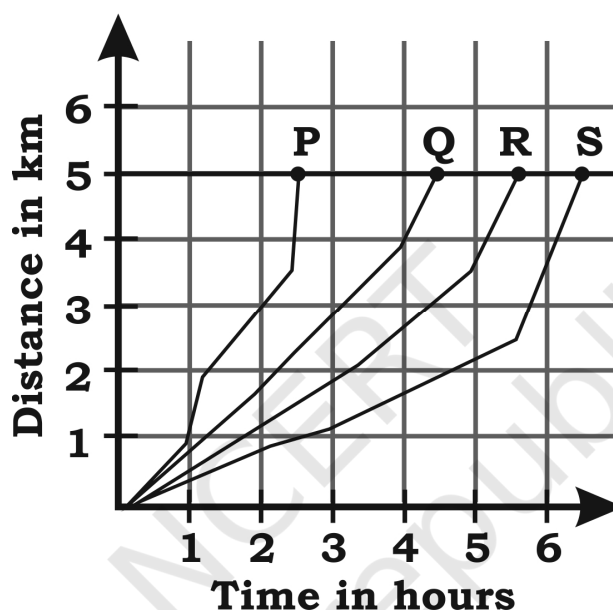

Who ran the slowest?

- (a) P
- (b) Q
- (c) R
- (d) S

Q2. The distance covered by the body between 20-30 seconds is

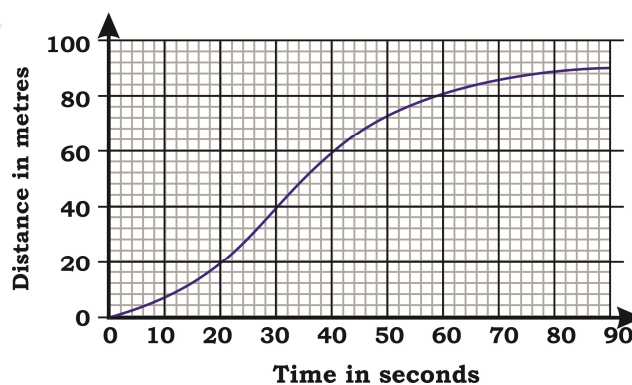

- (a) 40m
- (b) 50m
- (c) 60m
- (d) 20m

Q3. What is the speed of the body in the portion B to C and D to E?

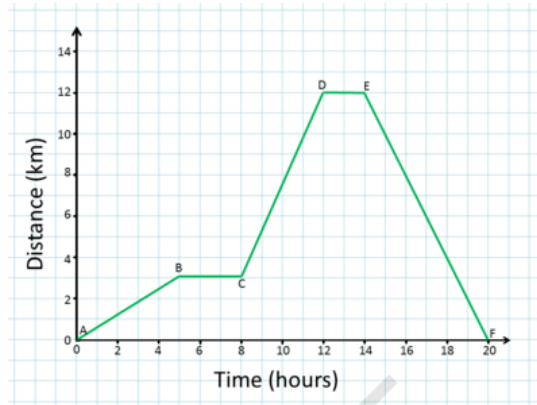

- (a) The object is moving away from the reference point at a constant speed.
- (b) The object is moving toward the reference point at a constant speed
- (c) The object is NOT moving
- (d) The object is speeding up

Q4. What is the position of the body in the time interval 60-70 seconds?

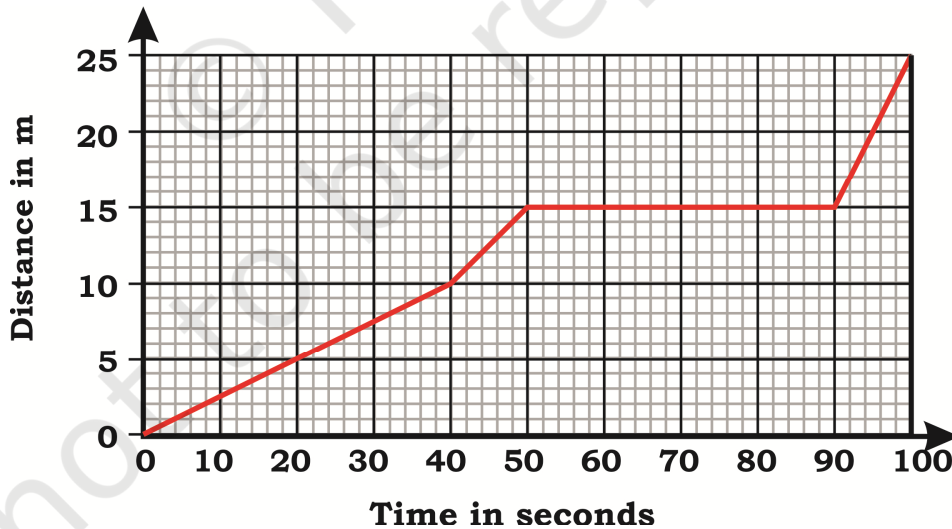

- (a) 15m
- (b) 5 m
- (c) 10 m
- (d) 20m

Q5. From the graph given shown below, which sentence best describes Hima Das, the athlete whose distance-time graph?

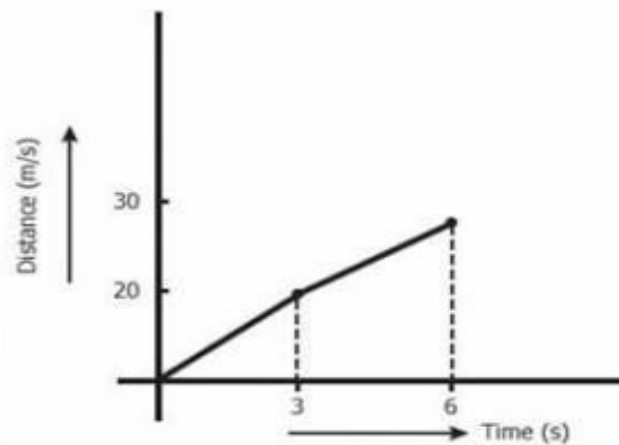

- (a) She ran forward for 3 seconds, and then he ran backward for 3 more seconds.
- (b) She ran forward for 3 seconds, and then he stood still for 3 more seconds.
- (c) She ran forward for 3 seconds, and then he ran forward for 3 more seconds but with a lower speed.
- (b) She ran forward for 3 seconds, and then he moved forward for 3 more seconds with a greater speed.

Q6. For a body performing motion with CONSTANT speed, the distance-time graph is:

- (a) Straight line parallel to y-axis
- (b) Straight line inclined to the time axis
- (c) Straight line parallel to x-axis
- (d) Curved line

Q7. Which of the following figures represent body is stationary (not moving at all) correctly?

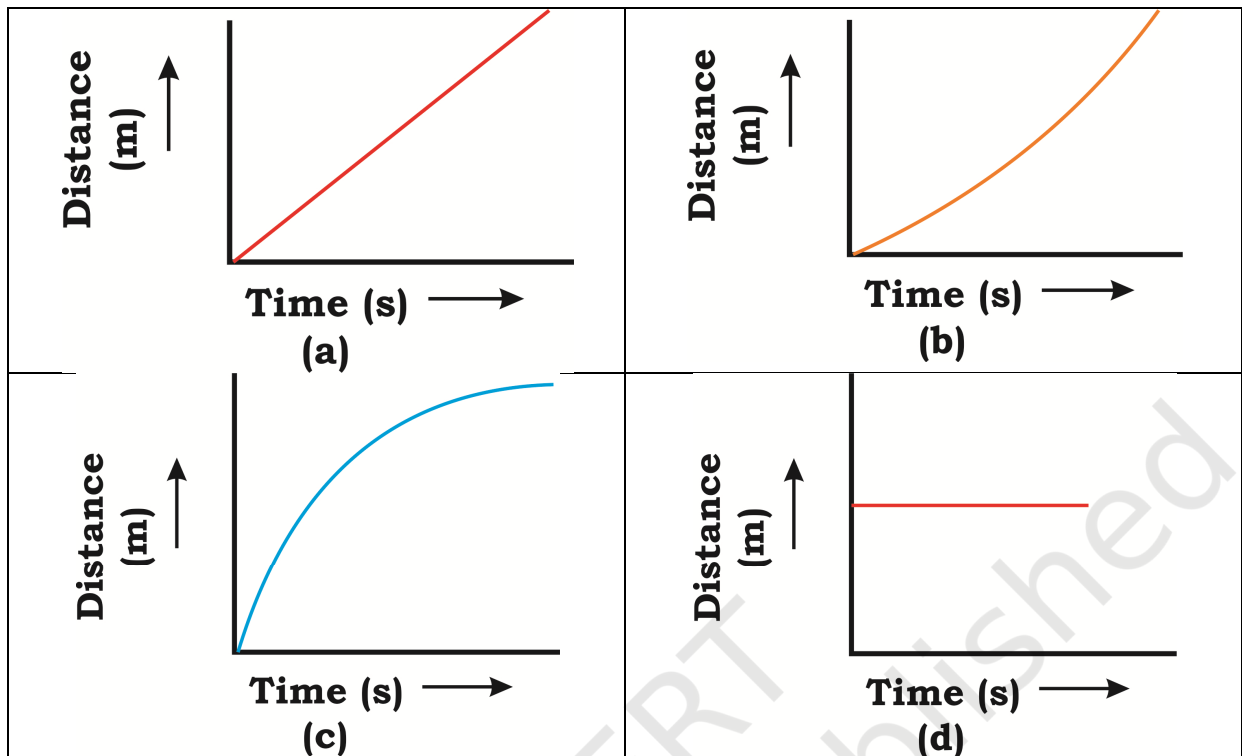

Q8. Distance-time graph of two objects A and B are shown below.

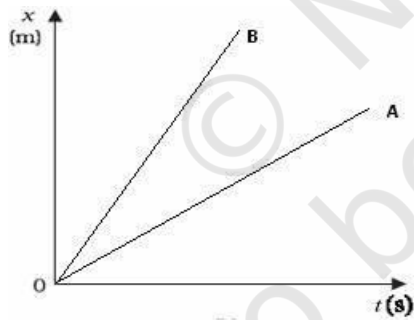

For the speed of object A and object B, which statement is true?

- (a) The speed of A is greater than that of B
- (b) The speed of A is smaller than that of B
- (c) Both have same speed
- (d) The speed of A is double the speed of B.

Worksheet: 66 (Mode: Face to Face) (LO-11)

Learning Outcomes to be achieved:

Constructs models using materials from surroundings and explains their working, e.g., stethoscope; anemometer; electromagnets; Newton's colour disc, etc.

You might have seen a crane picking up the pieces of iron junk from a heap of waste material in the junkyard. You may be thinking that a magnet is attached to the end the crane that picks up the iron. Would you like to try to construct a model of such crane?

Electromagnetic Crane

Using pieces of cardboard or wooden strips make a stand with a movable arm, as shown in the figure. Connect a metal screw (around 5 cm long) to the end of the movable arm.

Take around 75 cm long piece of insulated flexible wire. Wind the wire tightly around the screw in the form of a coil. Connect the free ends of the wire to the terminals of a cell through a key.

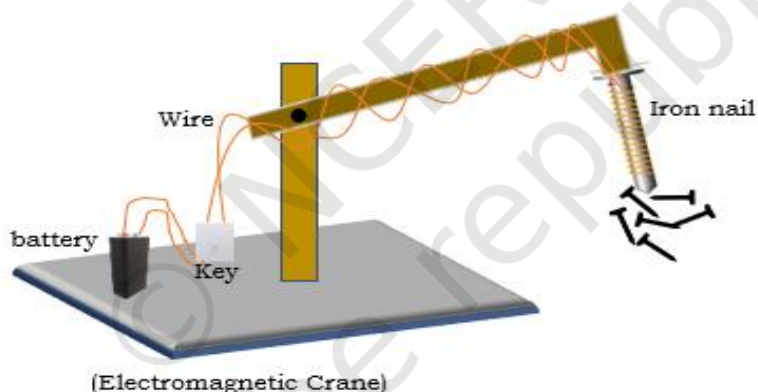

Place some pins or tiny iron nails below the metal screw. Close the key to switch on the current and take the screw end near the pins.

What do you observe?

.....
.....

Now switch off the current. What do you observe?

.....
.....

Now explain how an electromagnetic crane picks up the pieces of iron junk from a heap of waste.

.....
.....

Do you think an electromagnetic crane can be used for separating plastic bags from a garbage heap? Justify.

.....
.....

© NCERT
not to be republished

Worksheet: 67 (Mode: Face to Face)

Learning Outcomes to be achieved:

Constructs models using materials from surroundings and explains their working, e.g., stethoscope; anemometer; electromagnets; Newton's colour disc, etc.

Q1. Mira wanted to construct a model of a stethoscope. Enlist the materials that she can use to make the model.

.....
.....
.....
.....

Q2. Sia constructed a model of breathing mechanism in humans and replaced the rubber sheet with a piece of cloth. Will the balloons inflate on the pulling the cloth piece?
Justify your answer.

.....
.....
.....
.....

Q3. Explain working of the model shown in the diagram above.

.....
.....
.....
.....

Q4. When Rahul constructed the model shown in the diagram above then the plastic straw that he used had a small hole in it. Will the balloons inflate when the rubber sheet is pulled? Give reason for your answer.

.....
.....
.....
.....

Worksheet: 68 (Mode: Online)

Learning Outcomes to be achieved:

Constructs models using materials from surroundings and explains their working, e.g., stethoscope; anemometer; electromagnets; Newton's colour disc, etc.

- Q1. A student constructed a model of a Newton Disc. However, the model did not merge colours to show white light. Which of the following is NOT the possible reason of the default?
- (a) The colours - V, I, B, G, Y, O and R are not arranged in a sequential order.
 - (b) The rotation of Newton's disc is slow.
 - (c) The disc is being rotated anticlockwise
 - (d) The seven segments for seven colours are not equal.
- Q2. The model of an anemometer works on the principles of
- (a) hot air rises up
 - (b) air exerts pressure
 - (c) hot air is lighter than cold air
 - (d) High speed winds create low pressure.
- Q3. A group of four students constructed an electromagnet. They wanted to increase its strength so each one of them gave a suggestion. Which among the following suggestions is the best one to increase the strength of the electromagnet?
- (a) A steel nail must replace the iron one.
 - (b) Number of turns should be doubled
 - (c) The iron nail should be replaced by a bar magnet.
 - (d) Two batteries of 0.5 V each should replace a single IV battery.
- Q4. What is the purpose of diaphragm in a stethoscope?
- (a) To reflect the sound.
 - (b) To transmit the sound.
 - (c) To measure and records pulse rate/heart beat.
 - (d) To increases the loudness of the sound of heartbeat.

Worksheet: 69 (Mode: Online) (LO-12)

Learning Outcomes to be achieved:

Discusses and appreciates stories of scientific discoveries.

Q1. _____ was one of the first scholars who study friction systematically realizing the importance friction in the workings of machines. He studied on all kinds of friction and drew a distinction between sliding and rolling friction.

- a) Leonardo Da Vinci b) Newton c) Pascal d) Avogadro

Q2. A young **scientist**, in a contemplative mood, was sitting under an apple tree when he was hit on the head by a falling piece of fruit, a 17th-century “Aha moment” that prompted him to suddenly come up with his’ Law of gravity’.

The young scientist was.....

- a. Alexander Graham Bell
b. Benjamin Franklin
c. Thomas Edison
d. Issac Newton

Q3. The scientist is honoured by the SI (International Standard) unit of power, the Watt. In record, one horsepower equates to 746 watts. The name of the scientist is.....

- a) Newton
b) Celsius
c) James Watt
d) Graham Bell

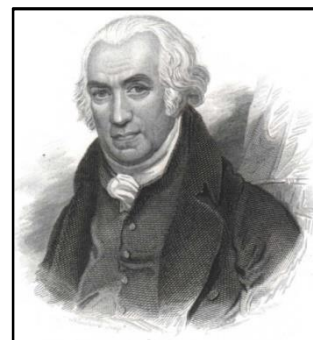

Q4. Vaccines save millions of lives each year. Edward Jenner is considered the founder of vaccinology. The world is in the midst of a COVID-19 pandemic. We are awaiting a vaccine. The function of the vaccine is.....

- a) To preventing illness
b) To treat the illness
c) To recover from the disease
d) To treat cancer

- Q5. Avul Pakir Jainulabdeen Abdul Kalam, also known as a missile man, was born and raised in Rameswaram, Tamil Nadu who served as the 11th President of India from 2002 to 2007. He was an Indian aerospace scientist and politician who studied physics and aerospace engineering. His made Missile is launched with the help of Rocket. The working principal of rocket is based on.....
- a) Kalam principal
 - b) Newton's third law of motion
 - c) Newton's second law of motion
 - d) Pascal principal

© NCERT
not to be republished

Worksheet: 70 (Mode: Online)

Learning Outcomes to be achieved:

Discusses and appreciates stories of scientific discoveries.

Q1. The First person who noticed the deflection of compass needle when the current was passed through the wire was:

- (a) Alessandro Volta
- (b) Hans Christian Oersted
- (c) Michael Faraday
- (d) Thomas Alva Edison

Q2. William Beaumont who was an American army doctor for the first time observed and study

- (a) Rumination
- (b) Tooth decay
- (c) Pseudopodia
- (d) Human Digestion

Q3. When the Romans attacked Syracuse, a scientist used mirrors as weapons. He arranged mirrors in such a way that they could be moved in any direction. They were positioned such that they reflected sunlight on the Roman soldiers who were dazzled by it. They got confused and ran away. Who among the following can be credited for this idea?

- (a) Archimedes
- (b) Aristotle
- (c) Euclid
- (d) Hippocrates

Q4. The electric bulb was invented by

- (a) Sir Issac Newton
- (b) Max Planck
- (c) Thomas Alva Edison
- (d) Albert Einstein

Q5. The English Physician, William Harvey discovered the

- (a) Human digestion
- (b) mechanism of urine formation
- (c) Circulation of blood
- (d) Presence of villi in the intestine

Worksheet: 71 (Mode: Face to Face) (LO-13)

Learning Outcomes to be achieved:

Applies learning of scientific concepts in day to day life, e.g., dealing with acidity; testing and treating soil; taking measures to prevent corrosion; cultivation by vegetative propagation; connecting two or more electric cells in proper order in devices; taking measures during and after disasters; suggesting methods for treatment of polluted water for reuse etc.

- **Apply learning of scientific concepts in day-to-day life.**
- **Appreciate the uses of bases in daily life.**
- **Know the properties of neutralization reaction.**

Raj was playing in a mud farm and he got bitten by ant. As he started crying, his mother immediately ran to kitchen and brought baking soda. She rubbed the baking soda on the affected area of Raj. Although the affected area became heated for a while but it soothed the pain gradually.

Answer the following questions based on the above incident-

1. The chemical name of baking soda is.....
2. What reaction is taking place in the incident?
3. Why baking soda does soothe the pain of an ant bite?
4. Why does the affected area become heated?
5. Can you figure out another alternative for baking soda used here?

Worksheet: 72 (Mode: Online)

Learning Outcomes to be achieved:

Applies learning of scientific concepts in day to day life, e.g., dealing with acidity; testing and treating soil; taking measures to prevent corrosion; cultivation by vegetative propagation; connecting two or more electric cells in proper order in devices; taking measures during and after disasters; suggesting methods for treatment of polluted water for reuse etc.

- Q1. When an ant bites, it injects the acidic liquid (formic acid) into the skin. The effect of the acid can be neutralised by rubbing moist baking soda (sodium hydrogen carbonate)



The name of the process of the remedies of ant bites is the most appropriate word is.

- a. acid treatment
 - b. base treatment
 - c. salt treatment
 - d. neutralization
- Q2. Which of the following acid is present in your favorite sirka (Vinegar)?
- a) Lactic acid b) Acetic acid c) Formic acid d) Oxalic acid
- Q3. Excessive use of chemical fertilizers makes the soil acidic. When the soil is either too acidic or too basic, plants do not grow well. If the soil is too acidic, bases like quick lime (calcium oxide) or slaked lime (calcium hydroxide) is treated with soil and if it is too basic, organic matter is used which releases acid.
- The nature of the soil should be so that crops can grow well or gives maximum yields
- a) Acid b) basic c) strongly acidic d) neutral
- Q4. What is the nature of Ammonia which turns red litmus blue, found in many household products, such as window cleaners?
- a) Acid b) basic c) neutral d) salty

Q5. The reaction between an acid and a base is known as neutralization. In neutralization process, salt and water are produced with the evolution of heat. This reaction helps in our daily life situation. For example for reducing acidity in stomach we used generally the substance/ chemical called antacid is

- a) Sodium chloride
- b) Milk of magnesia (magnesium hydroxide)
- c) Vinegar
- d) Curd.

Q6. The iron pipes that is used to carry water at our homes are galvanized (a process of depositing a layer of zinc on iron) to prevent rusting.

The zinc layer prevents rusting from coming in contact withandor both.

Complete the sentence from the following suitable option

- a) Water, oxygen
- b) Hydrogen, oxygen
- c) Nitrogen, hydrogen
- d) Hydrogen, helium

Q7. Following steps are involved in the purification of water; the proper sequence of the purification is.....

- (i) The passing of water through bar screens removed all the physical impurities like stones, plastic bags, cans etc.
- (ii) Secondly, impurities are removed by sedimentation after taking water to a grit and sand removal tank.
- (iii) Thirdly, solid impurities and faces etc. called sludge are collected from the bottom of water.
- (iv) With help of aerator, clarified water is cleaned of other impurities. By chlorination all disease causing bacteria are removed.

- a) i < ii < iii < iv
- b) iv < ii < iii < i
- c) iii < i < ii < iv
- d) ii < i < iii < iv

Q8.

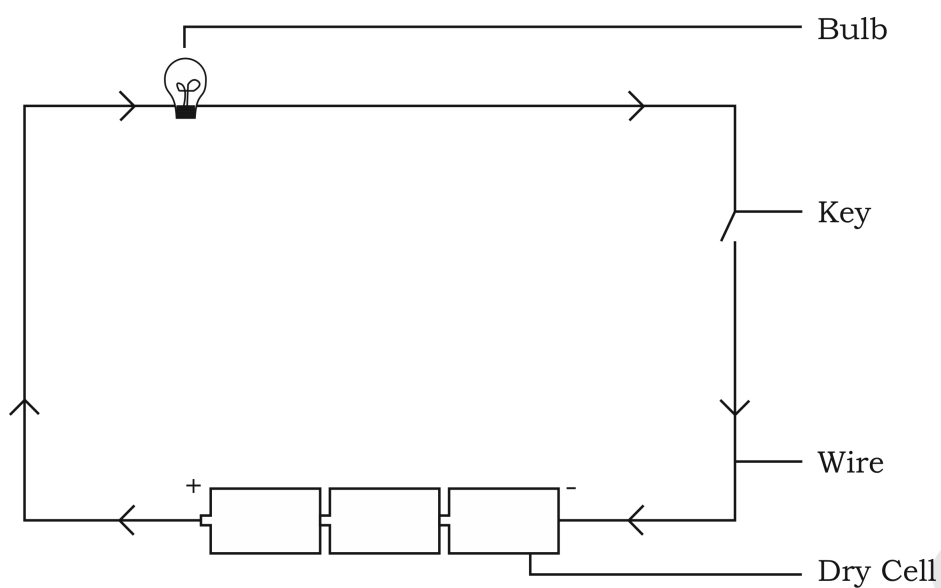

Diagram of a battery by joining 3 dry cells

The above picture represents circuit of the cell, the proper arrangement of cell to complete a circuit is

- a) Positive terminal of a cell is connected with positive terminal of another cell
- b) Positive terminal of a cell is connected with negative terminal of another cell
- c) Negative terminal of a cell is connected with negative terminal of another cell
- d) They should be connected in parallel.

Worksheet: 73 (Mode: Online) (LO-14)

Learning Outcomes to be achieved:

Makes efforts to protect environment, e.g., following good practices for sanitation at public places; minimising generation of pollutants; planting trees to avoid soil erosion; sensitising others with the consequences of excessive consumption of natural resources, etc.

- Q1. If you practice _____. You are protecting preserving and managing Earth's natural resources.
- (a) Deforestation
 - (b) Conservation
 - (c) Fragmentation
 - (d) Exhalation
- Q2. _____ is a change to the environment that is harmful to humans and other living beings.
- (a) Pollution
 - (b) Reforestation
 - (c) Infiltration
 - (d) Transpiration
- Q3. Which of the following statements is not correct
- (a) If forest disappear, the amount of carbon dioxide in air will increase
 - (b) In absence of trees and plants, the animals will not get food and shelter
 - (c) Forest does not influence climate, water cycle and air quality.
 - (d) The forest keeps on growing and changing, and can regenerate.
- Q4. Soil erosion can be checked by
- (a) Preventing deforestation
 - (b) Cutting trees
 - (c) Heavy rain fall
 - (d) Increasing moisture in the soil
- Q5. Which of the following is not responsible for the depletion of water table?
- (a) Increasing Population
 - (b) Deforestation
 - (c) Soil Conservation
 - (d) Increasing Industries

Worksheet: 74 (Mode: Online) (LO-15)

Learning Outcomes to be achieved:

Exhibits creativity in designing, planning, making use of available resources etc.

Q1. A farmer wants to grow three different crops in his field. Suggest the types of soils and suitable crops from the following given table:

	Types of soil		Properties		Crops suitable for growing
1	Loamy	i	Rich in Organic matter	a	Melon
2	Clayey	ii	Low in nutrient content	b	Pulses
3	Sandy	iii	Rich in humus	c	Sugarcane

Choose the correct match:

- A. 1→ii→b, 2→i→b, 3→iii→c
- B. 1→iii→c, 2→i→b, 3→ii→a
- C. 1→i→a, 2→ii→b, 3→iii→c
- D. 1→iii→b, 2→i→a, 3→ii→c

Worksheet: 75 (Mode: Online) (LO-16)

Learning Outcomes to be achieved:

Exhibits values of honesty, objectivity, cooperation, freedom from fear and prejudices.

In a lab experiment, teacher provided small amount of phenolphthalein indicator to every student in order to make them understand the difference of Acid and Base. Raj spoiled indicator provided to him by mistake.

Based on the above incident, answer the following:

1. What would you do in place of Raj?
 - (a) Fake the results
 - (b) Apologize to your teacher and ask them to provide more indicator solution
 - (c) Run out of the lab without mentioning to your teacher
 - (d) Copy the results from other student
2. Which property is exhibited in relation to previous question?
 - (a) Honesty
 - (b) Co-operation
 - (c) Justice
 - (d) Kindness
3. Phenolphthalein turns to which color in presence of base?
 - (a) Black
 - (b) Colourless
 - (c) Blue
 - (d) Pink
4. Phenolphthalein turns to which colour in presence of Acid?
 - (a) Black
 - (b) Colourless
 - (c) Blue
 - (d) Pink



विद्यया ऽ मृतमश्नुते



एन सी ई आर टी
NCERT

**Department of Education in Science and Mathematics
National Council of Education Research and Training
Sri Aurobindo Marg, New Delhi - 110016**