

**43rd Jawaharlal Nehru National
Science, Mathematics and Environment
Exhibition for Children**

Structure and Working of Exhibits



13-19 December

2016



Bengaluru, December 13-19, 2016

Structure and Working of Exhibits

**43rd Jawaharlal Nehru National Science,
Mathematics and Environment
Exhibition for Children**



विद्यया ऽ मृतमश्नुते



एन सी ई आर टी
NCERT

**राष्ट्रीय शैक्षिक अनुसंधान और प्रशिक्षण परिषद्
NATIONAL COUNCIL OF EDUCATIONAL RESEARCH AND TRAINING**

November 2016 Agrahayana 1938

PD 5T BS

© **National Council of
Educational Research and
Training, 2016**

Published at the Publication
Division by the Secretary,
National Council of Educational
Research and Training, Sri
Aurobindo Marg, New Delhi
110 016 and printed at Gita
Offset Printers (P) Ltd., C-90,
Okhla Industrial Area, Phase-I,
New Delhi 110 020

ALL RIGHTS RESERVED

- No part of this publication may be reproduced, stored in a retrieval system or transmitted, in any form or by any means, electronic, mechanical, photocopying, recording or otherwise without the prior permission of the publisher.
- This book is sold subject to the condition that it shall not, by way of trade, be lent, re-sold, hired out or otherwise disposed of without the publisher's consent, in any form of binding or cover other than that in which it is published.
- The correct price of this publication is the price printed on this page. Any revised price indicated by a rubber stamp or by a sticker or by any other means is incorrect and should be unacceptable.

OFFICES OF THE PUBLICATION

DIVISION, NCERT

NCERT Campus
Sri Aurobindo Marg
New Delhi 110 016 Phone : 011-26562708

108, 100 Feet Road
Hosdakere Halli Extension
Banashankari III Stage
Bangaluru 560 085 Phone : 080-26725740

Navjivan Trust Building
P.O.Navjivan
Ahmedabad 380 014 Phone : 079-27541446

CWC Campus
Opp. Dhankal Bus Stop
Panihati
Kolkata 700 114 Phone : 033-25530454

CWC Complex
Maligaon
Guwahati 781 021 Phone : 0361-2674869

Publication Team

Head, Publication Division : *M. Siraj Anwar*

Chief Editor : *Shveta Uppal*

Chief Business Manager : *Gautam Ganguly*

Chief Production Officer (*Incharge*) : *Arun Chitkara*

Editor : *Bijnan Sutar*

Production Assistant : *Mukesh Gaur*

Cover Design

Ajeet Kumar

PREFACE

The learning of Science and Mathematics are instrumental in developing well-defined abilities and skills such as spirit of enquiry, creativity, objectivity, logical thinking and aesthetic sensibilities among children. Children learn through interactions with the environment around, nature, things and people. They actively engage with the world around them in exploring, responding, inventing, working things out and interpreting. Jawaharlal Nehru National Science, Mathematics and Environment Exhibition (JNNSMEE) for Children offers an opportunity to children to express and exchange their creative ideas with joy of scientific investigation. It helps them to learn the methods of science and mathematics, provide them with opportunity to develop their problem-solving skills and creative abilities.

The National Council of Educational Research and Training (NCERT) organises the Jawaharlal Nehru National Science, Mathematics and Environment Exhibition (JNNSMEE) for Children as an annual event in collaboration with a State or Union Territory. The JNNSMEE is the culminating activity of a series of exhibitions organised at school, zonal, district, regional and state levels. A large number of students and teachers participate in such events.

The present publication, 'Structure and Working of Exhibits' includes write-ups of a few exhibits selected for display in the 43rd JNNSMEE-2016 which is being organised in collaboration with the Ministry of Primary and Secondary Education, Government of Karnataka at the Bengaluru International Exhibition Centre, Bengaluru during 13-19 December 2016. Other materials like 'List of Exhibits' which contains the titles and synopsis of exhibits

selected for participation in the JNNSMEE–2016 along with information brochures stating objectives and other details of the exhibition have also been published. It is expected that these publications will motivate and help children to participate in future Exhibitions.

The write-ups included in the present publication were selected out of the entries received from all the States/UTs and other organisations. These were reviewed and edited by an expert committee in the Department of Education in Science and Mathematics, NCERT.

Completing the task related with the editing and publishing of this booklet has been possible because of the continuous efforts of my colleagues Shri R.R. Koireng and Dr. A.K. Srivastava. I also thank Dr. Gagan Gupta for coordinating the task. Further, I thank Mr. Jai Kumar, Mr. Hari Darshan Lodhi for helping the department in bringing out this booklet.

New Delhi
22 November 2016

DINESH KUMAR
Professor and Head
Department of Education in
Science and Mathematics
National Council of Educational
Research and Training

CONTENTS

<i>Preface</i>	<i>iii</i>
1. Amazing Straw Cutter	1
2. Earthquake Proof Buildings	3
3. Pollution Control Chimney	8
4. Eco-friendly Enzyme for Garbage	13
5. Electric Free Mini Vacuum Cleaner	17
6. Multi-purpose unit for Farmer	19
7. Simple Seed Sower (SSS)	23
8. <i>Jugad</i> Technology in Agriculture	26
9. Bicycle Based Equipment for Agriculture	29
10. Solar Weeder	32
11. Multitasking Agricultural Machine	34
12. Instrument for Climbing on the Pole	41
13. Solar Mixer Machine	43
14. Eco-friendly Plastic	46
15. Automatic Street Light	48
16. Wonder Wheel Chair	52
17. Remote Operating Agriculture Machine	56
18. Mat Making Machine for <i>Divyangs</i>	59
19. Smoke Purifier	62
20. धुँए को वायुमण्डल में जाने से नियंत्रित करने हेतु विशेष चूल्हा	64



Empowerment of Girl Child, Responsibility of All

AMAZING STRAW CUTTER

STUDENT

Takhellambam Amrabati Chanu

Anandapura School,
Thoubal Tomjing
Makhong, Thoubal,
Manipur**TEACHER**T. Robindro Singh

INTRODUCTION

Paddy straws are widely used as fodder, in mushroom cultivation, soil mulching etc. For these purposes, straws are required to be cut in large scale. The devices which are available in the markets are costly and not easily affordable to the majority of the Indian farmers.

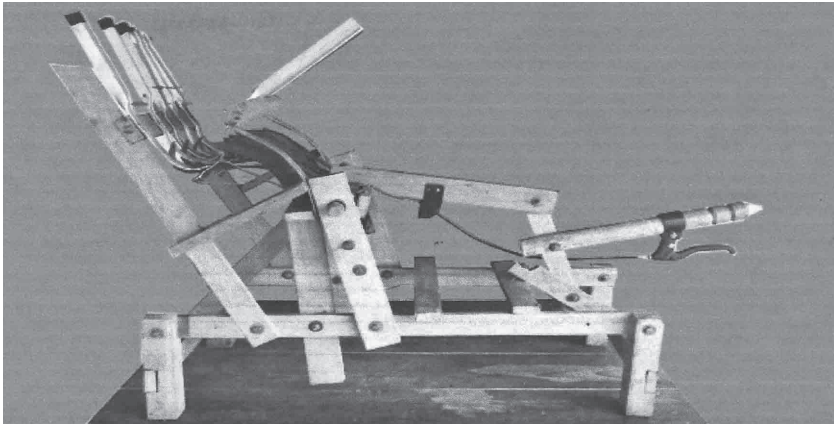

Fig. 1: Amazing straw cutter

The traditional straw cutter have only one blade and have limitation for cutting straw in large scale. In view of this, a model called Amazing Straw Cutter is being developed.

SCIENTIFIC PRINCIPLE INVOLVED

Amazing Straw Cutter is based on the scientific principle of lever.

MATERIAL REQUIRED

An iron rod, nuts and bolts, aluminium cuboid pipe, nails, cycle cable brake, rubber belts and a wooden piece.

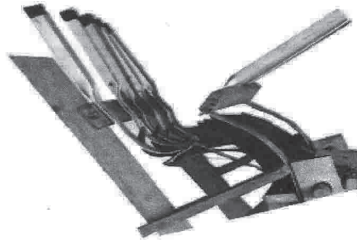

Fig. 2: Blade Frame

CONSTRUCTION

A rectangular base frame is made and five sickles are fixed at a particular height from the frame so as to cut four bunch of straw simultaneously. Four hooks along with its grippers are fixed on a lever. Above the hooks, straw chamber is fixed.

WORKING

When the lever is up, the four hooks collect the straw from the straw chamber. When the lever is pushed down, the fixed five vertical sickles enable to cut the horizontally collected straws in a regular manner. In one cycle of movement of lever, one can enable to cut the straws in four pieces simultaneously.



Fig. 3: Lever (Handle)

ADVANTAGES

- i) Amazing straw cutter can cut straws in a large scale with minimum labour.
- ii) By using this straw cutter, chances of injury from the sickles are very low compare to the traditional one.
- iii) Amazing straw cutter is low cost, farmers can afford easily.
- iv) Amazing straw cutter will give benefits to the cultivation of mushrooms, rearing of cattle and mulching of soil.

EARTHQUAKE PROOF BUILDINGS

STUDENTS

Pranab Pandey
Aaditya Newaskar

DAV International School,
Plot No-31, Sec-15,
Kharghar, Navi Mumbai,
Maharashtra

TEACHERS

Preeti Sama
Sangeeta Ningule

INTRODUCTION

‘Mitigation strategies’ is the process of developing options and actions to enhance opportunities and reduce threats to buildings.

The perceptible shaking of the surface of the Earth due to sudden movement of plates below the surface of Earth, results in the sudden release of energy thereby generating seismic waves. This causes unwanted vibrations inducing possible structural failure, discomfort and malfunction of equipment. Our approach to mitigate the hazardous effect of earthquake is based on consideration of the distribution of energy within a structure.

SCIENTIFIC PRINCIPLE INVOLVED

- **Law of Inertia:** The law of inertia states that it is the tendency of an object to resist a change in its state of rest or motion.
- **Energy Dissipation:** During a seismic event, the energy from the ground is transformed into both kinetic and potential energy which must be either absorbed or dissipated through heat. The inherent energy dissipation capacity of the structure will eventually withdraw all the seismic input energy from the structure. This approach can be understood by following time dependent conservation of energy relationship.

$$E(t) = E_k(t) + E_s(t) + E_h(t) + E_d(t)$$

where E is the absolute energy input from the

earthquake motion; E_k is the absolute kinetic energy; E_s is the absolute elastic strain energy; E_h is the energy dissipated by the structure due to inelastic or the other forms of action; E_d is the energy dissipated by supplementary damping system; and t is the time.

MATERIAL REQUIRED

- i) *For shake table:* Plywood, metal clamps, springs, screws, metal shaft and cycle axle hub assembly without the spokes.
- ii) *For building:* Metallic scales (24 inches), plywood, metallic bob, screws and metallic elbow.
- iii) *For dampers:* Glass bend tubes, plastic trough, perforated plastic sheets and weights.
- iv) *For base isolator:* Soft board, metal rods, watch glass, petridish and marbles.
- v) *Miscellaneous:* Mount board, umbrella spokes, stationery and spray paints.

CONSTRUCTION AND WORKING

Tuned mass damper:

A harmonic absorber is a device mounted in structures to reduce the amplitude of mechanical vibrations. The frequency of the damper is tuned to a particular structural frequency so that when that frequency is excited the damper will resonate out of phase with the structural motion therefore the energy is dissipated as relative motion develops between mass and structure.

Tuned liquid damper

During a seismic event, the fluid in this tank will slosh back and forth, but is directed by baffles-partitions that prevent the tank itself becoming resonant; through its mass the water may change

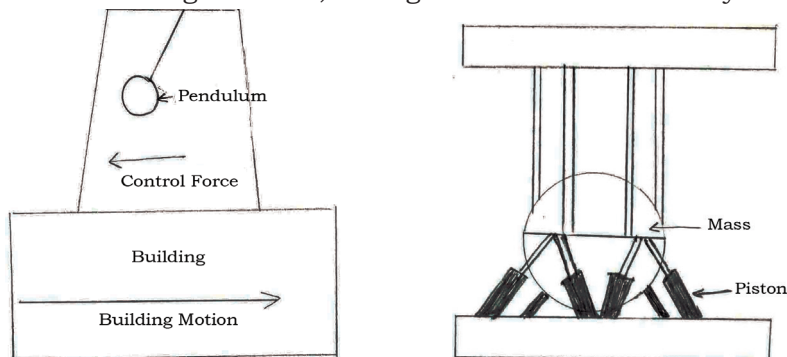

Fig. 1: Tuned mass damper

or counter the resonant period of the building. Additional kinetic energy can be converted to heat by the baffles and is dissipated through the water, any temperature rise will be insignificant.

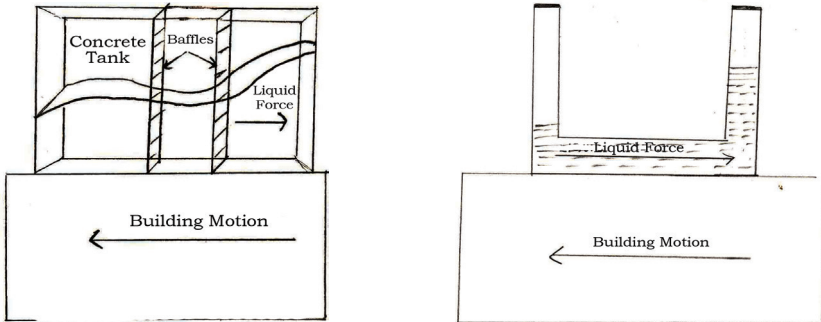

Fig. 2: Tuned liquid damper

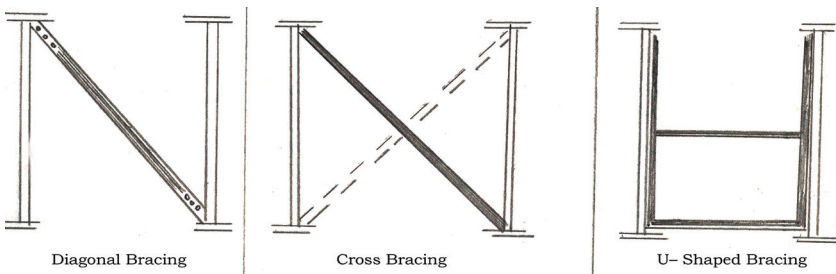

Fig. 3: Braces

Braces

Bracing is a system utilised to reinforce building structures. There are two types of bracing. First is torsion bracing. Torsion bracing takes the form of a plane of bracing between a pair of beams. The principal advantage of this type of bracing is that a pair of beams is a stable unit. Advantages of this type of bracing over plane bracing are that it is located below the deck slab and therefore does not interfere with the construction of the concrete deck, and it can serve to distribute collision and wind loads more effectively. The effect of torsion bracing is to increase the elastic critical movement for each beam, although it will not increase it to the value for buckling over a half wave length equal to the spacing of the bracing. It is not ‘fully effective’ in the way that plane bracing is. The bracing does not provide any lateral

restraint to the compression flange, as one beam will simply use the bracing to push the other beam sideways. To overcome this, another type of bracing is used called U-framed bracing. U-frame action is generally used to resist buckling.

Base isolation

In a base isolated structure series of bearing pads that have a curved surface and a low friction are placed between the building and the building's foundation. The building's displacement in the direction opposite the ground motion due to inertia generated by an earthquake is reduced by decreasing the acceleration of the building. Acceleration is decreased because the base isolation system lengthens a building's period of vibration and prevents its deformation.

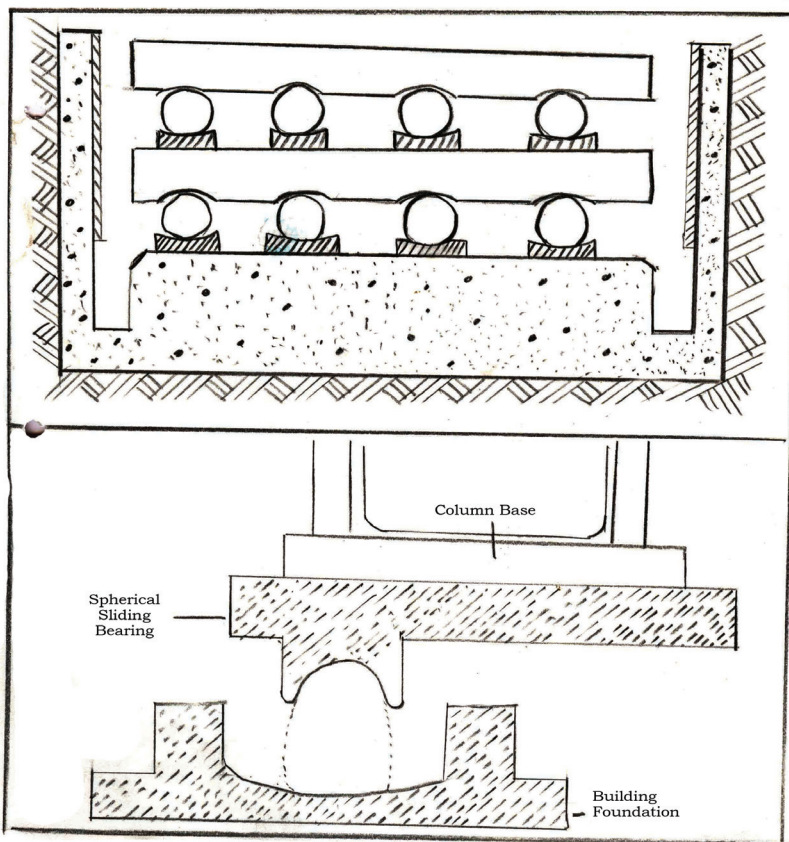

Fig. 4: Base isolation

APPLICATIONS

- Energy dissipation devices and the base isolation system are successful in making a building earthquake resistant.
- Reduces the vibrations and its effects on the structure in cantonment areas while moving of military tanks and heavy vehicles.

REFERENCES

- i) https://en.wikipedia.org/wiki/Elastic_modulus
- ii) https://en.wikipedia.org/wiki/Tuned_mass_damper
- iii) <https://www.youtube.com/watch?v=ttDpEQUlxrl>
- iv) <https://www.youtube.com/watch?v=ttDpEQUlxrl>
- v) http://www.reidsteel.com/information/earthquake_resistant_building.htm
- vi) <ethesis.nitrkl.ac.in/4938/1/211CE2023.pdf>

POLLUTION CONTROL CHIMNEY

STUDENTS

Dewash Dahal
Abinash Pradhan
Susan Gurung
Allen Smriti Rai

Government Senior Secondary
School, Namchi, South Sikkim,
Sikkim

TEACHER

Bikash Pradhan

INTRODUCTION

Factories and industries are a necessity for the development of a nation. But it is also very obvious that they cause pollution and happens to be the main cause of Global Warming. The harmful gases emitted by the factories mainly consist of the greenhouse gases, especially carbon dioxide. CO_2 is mostly given out due to the burning of fossil fuels. These gases contribute a lot to the acidification of rain, chemical spills and disposal of toxic wastes.

Another such dangerous gas emitted is sulphur dioxide, the key component involved in the formation of acid rain that corrodes our historic monuments and heritage structures and does a lot of harm to life.

Ozone (O_3) is also such another dangerous pollutant. Ozone is dangerous to lungs. Regardless of being useful in the upper layers of the atmosphere, its disadvantages too cannot be neglected. Even though it acts as a blanket to block the harmful UV radiations of the sun, it is very harmful to health in the lower layers if present in excess amount.

Electricity producing factories also cause a lot of pollution. Coal is mainly utilised in this process. The burning of this fossil fuel emits a lot of CO_2 along with nitrogen and sulphur oxides, hydrogen chloride and hydrogen fluoride gases and arsenic, lead and other metals. Even the least polluting natural Gas too emits CO_2 and oxides of nitrogen.

So even if the factories and industries are doing a great good to us, it also has got a lot of disadvantages, especially related to pollution. And Global Warming, one of the serious problems

caused by them has been a main concern in today's world. And CO_2 is the main component involved in the cause of global warming. Several efforts are therefore made to control this problem. The model '*Swacchha Sikkim Pollution Control Chimney*' is also an effort for the same. Through this, we can check the liberation of CO_2 and SO_2 and thus control pollution across the world.

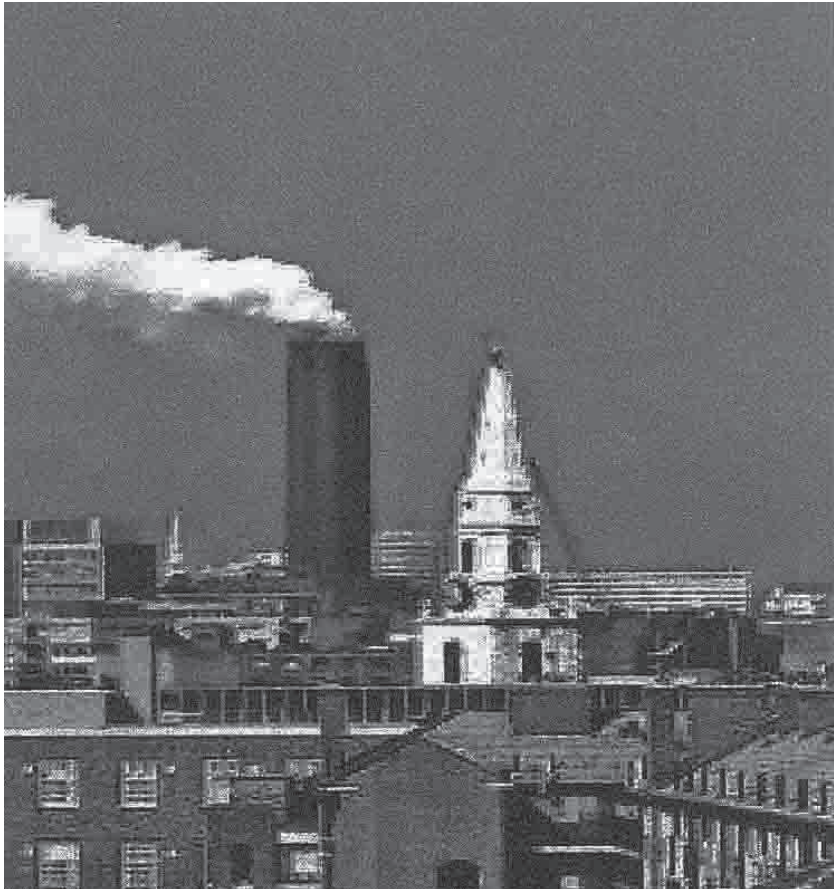

Fig. 1: Pollution from chimney

SCIENTIFIC PRINCIPLE INVOLVED

The model '*Swacchha Sikkim Pollution Controller Chimney*' is based on the principle of:

- i) Adsorption
- ii) Expansion of gases due to heat

Adsorption is the adhesion of particles of matter/adsorbate (atoms, ions, or molecules) to the surface of the adsorbent. It is a surface phenomenon.

Adsorbent—It is a substance or material that has the capability of adsorbing another substance or the tendency to let the particles of the adsorbate get accumulated on its surface. Some common examples of adsorbent are—silica gel, activated alumina, activated carbon, etc.

Adsorbate—It is the molecular species that gets adsorbed to the surface of the adsorbate.

Adsorption occurs in easily liquefiable gases, like CO_2 and SO_2 . The extent of adsorption depends upon factors such as:

- The surface area of the adsorbent.
- Activation of the adsorbent.
- Nature of the adsorbent and adsorbate
- Conditions like pressure and temperature. For example, the greater the pressure on the adsorbent, the greater will be the adsorption.

Gases on being heated, expands and rises so desorption can take place.

MATERIAL REQUIRED

The body of the model '*Swacchh Sikkim Pollution Control Chimney*' has been mainly made up of plywood. The other required materials are tin, nail, glass, muslin cloth, coconut, charcoal, wire, battery, switch, paint, brush and incense stick (used in place of fuels like coal or wood).

CONSTRUCTION AND WORKING

The model prepared is an apparatus to let the emitted CO_2 and SO_2 be adsorbed to the surface of the charcoal and not let to move out into open. The model is cuboid in shape. It is 60cm in height and about 16cm width and Length. The model is open at the bottom and has a door at the side. The rest of the part forms an air-tight passage. At a certain height, the passage is given a diversion. This is done by making a hole on the wall of the apparatus and then fixing another cuboid of smaller size made up of the same material. Since, the exhibit is open at the bottom, it can be placed over an exothermic reaction going on. When the exothermic reaction (here, burning of incense stick) is going on which releases gases, the emitted gas, being warm, rises up. The passage, being air tight, ensures that the gas does not escape. When it reaches the maximum height, being unable

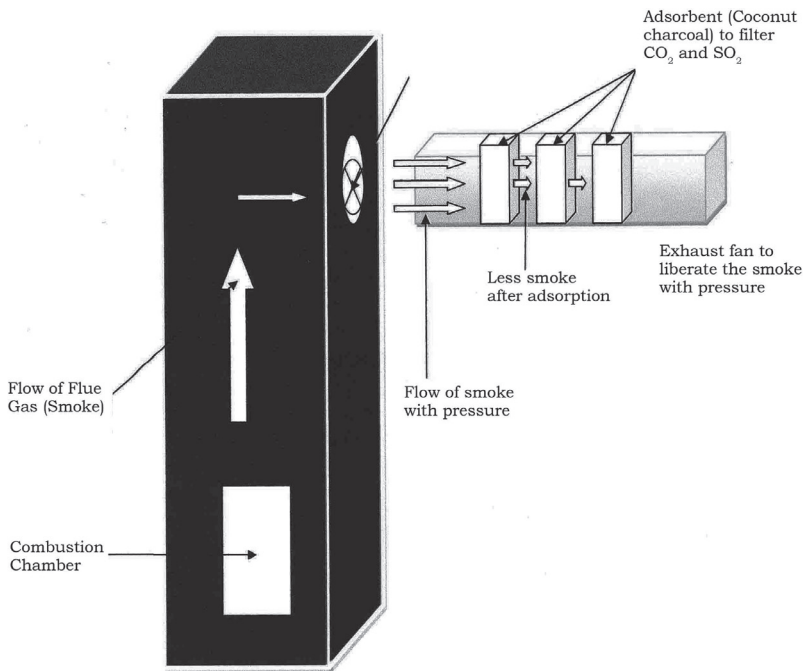

Fig. 2: Working of Swacchh Sikkim Pollution Control Chimney

to rise further, it makes its way towards the other smaller passage that forms the diversion for the bigger passage. Now, this is where the actual process of adsorption takes place. To make it easier for the emitted gas to move towards the smaller passage, an exhaust fan is used. It pulls the gas towards itself and lets it pass through it. Now, behind the exhaust fan, five slots of coconut charcoal, packed in muslin cloth is kept. The CO_2 and SO_2 molecules get adsorbed or adhered to the coconut charcoal in the slots.

And the charcoal that will have adsorbed the emitted gas can be heated for desorption and utilise the CO_2 and SO_2 gas for a useful purpose, like the preparation of sulphuric acid etc.

Not only this, the chimney also acts as solar chimney which is a low cost ventilating system. It is painted in black. When the walls of the chimney gets heated due to the solar energy, the gases inside it expands and rises, thus making it act as a suction pump, sucking air from where the chimney is built.

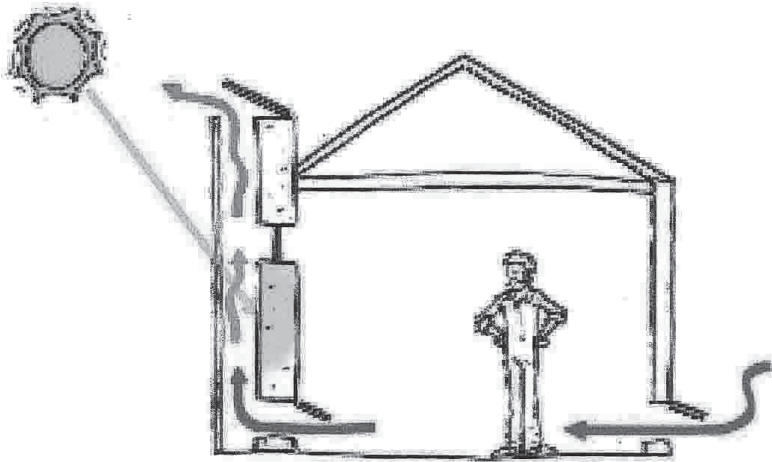

Fig. 3: Working of solar chimney

APPLICATIONS

This 'Swacchha Sikkim Pollution Control Chimney' can be built in industries to trap the emitted CO_2 and SO_2 and check pollution. The CO_2 and SO_2 adsorbed in the activated charcoal can be utilised for other useful purpose like manufacturing of acids. It can also be built in homes or factories or any other building.

REFERENCE

- i) Yang R.T.; State University of New York 14260; Comparison of activated Carbon and Zeolite13X for recovery of CO_2 from flue gas.
- ii) Wikipedia/Internet.

ECO-FRIENDLY ENZYME FOR GARBAGE

STUDENTS

Aparajitha Nair
Ritik Rathi

ASN Senior Secondary
School, Mayur Vihar-1,
Delhi

TEACHER

Alka Gupta

INTRODUCTION

Each time we use cleaning products made with chemicals, we are already polluting the underground water, rivers and the surrounding eco-system. Modern cleaning products usually contain harmful chemicals such as phosphate, nitrates, ammonia, chlorine etc. The accumulation effect of these chemicals released from every households can cause significant damage to the planet earth.

In an effort to help save our environment we would like to introduce the idea of producing homemade eco-friendly enzyme. Eco-enzyme is developed in Thailand. It can easily replace soaps, detergents and other cleansing product for household purposes. This would greatly control the production of harmful chemicals which ultimately leads up to major disasters. Hence, our proposal would also act as means to manage disasters. As the name suggests, our enzyme is totally made out of waste or garbage product.

SCIENTIFIC PRINCIPLE INVOLVED

According to research, forty-five per cent of household waste is organic waste such as fruit peels. Thus, this proved that the main material of the garbage enzyme preparation was easily obtained daily. Precautions have to be taken, if the container used is completely air-tight, make sure the container cap was released at least once a day for the first few weeks to let out built-up gas of fermentation in order to avoid any explosion due to high pressure exertion from the fermentation gas released. These gases are O_3 , NO_3 and CO_3 which purifies atmosphere. Importance of enzyme is that it is a very good cleaning substance.

It can be mixed with chemical cleaning agents too in order to reduce its harmful effects on our environment. Our enzyme has the amazing power of saving humanity from natural disasters. The enzyme has a fruity smell. This enzyme has the ability to do things like removing water and salt stains in shoes and boots, giving leather shoes and bags a better shine. It can even eliminate manufacturing chemicals from new clothes, remove soap scum and clean the hoses of our washing machine. It also soothes sunburns, remove foul odour and freshens air in bathroom.

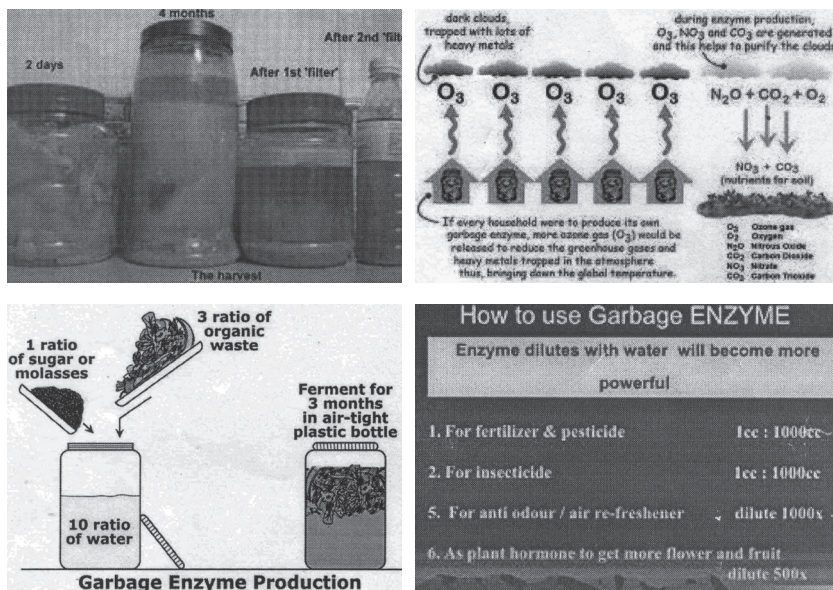

Fig. 1: Diagrammatic representation

MATERIAL REQUIRED

All we require to make this eco-friendly enzyme is vegetable/fruit waste, jaggery/brown sugar and water. We also need an air tight container to put all these into it and keep it for 3 months.

WORKING

The procedure involves:

- i) Fill $\frac{1}{4}$ th of the bottle with sugar/jaggery
- ii) Fill another $\frac{1}{5}$ th of the bottle with vegetable/fruit waste.
- iii) Fill the rest of the remaining with water.
- iv) Keep it in a cool place and in room temperature for 3 months.
- v) Open the lid after one month for 2-3 minutes to release the gases formed within.
- vi) Keep it for 3 months.

SCOPE OF THE PROJECT

- The most important benefit of our enzyme is that it can also help us to save lives before any major disaster. The residue part of the enzyme starts to surface from ground few minutes before an earthquake. This will help people in saving their own lives.

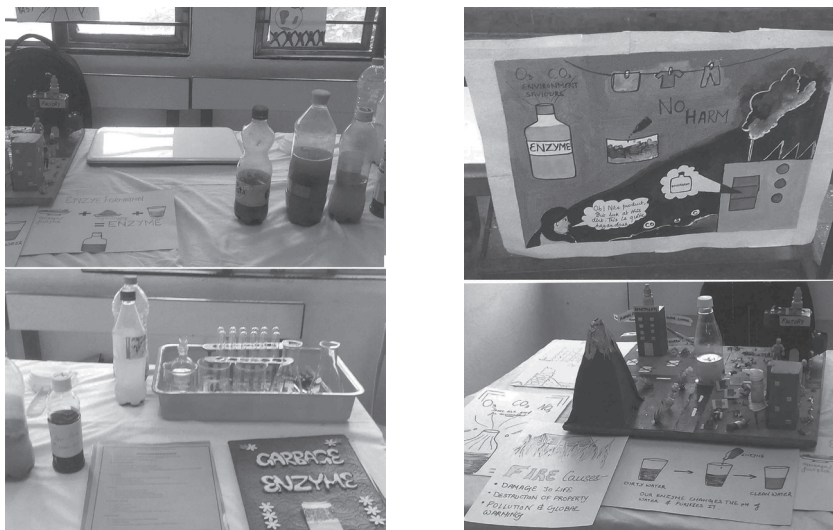

Fig. 2: Garbage enzyme

- This enzyme is also a much better extinguisher than the fire extinguishers or water.
- Reduce usage of chemical cleansers by using a mixture of our eco-friendly enzyme and water. This also results in reduction in the number of trees that are cut to make these chemicals. Now, if the trees are saved, then the possibility of earthquake tends to zero. Save The Earth!
- The fermentation of kitchen waste in making eco-friendly enzyme creates gases that lower the levels of carbon dioxide in the air.
- If produced on a mass level this enzyme can be used to even cleanse our water bodies from all chemical and other impurities thereby help save our environment from disasters.
- It can be promoted as an easy to make and economical popular household cleanser which is effective for killing most mold, bacteria, and germs.

- What's more, we can even use the residue of this enzyme as a fertilizer which can even convert sandy soil to fertile soil.
- Economical and other benefits of eco-friendly enzyme.

REFERENCES

- i) <http://www.o3enzyme.com/enzymeproduction.htm>
- ii) http://suprememastertv.com/services_subt.phb?bo_table=pe&wr_id=125&subt_cont=aw&show=aw&flag_s=
- iii) <http://hubpages.com/heath/Garbage-enzyme>

ELECTRIC FREE MINI VACUUM CLEANER

STUDENT

Premson Yengkhom

The Evergreen
Flowers' School,
Thoubal
Manipur

TEACHER

Th. Chandra Singh

INTRODUCTION

Cleaning is one the most important work in our daily life. At the time of cleansing work, the dust particles present often enter to our body through respiration and it causes health hazard. To solve this problem "Electric Free Mini Vacuum Cleaner" has been designed.

SCIENTIFIC PRINCIPLE INVOLVED

Air from the tank is pumped out using the siphon.

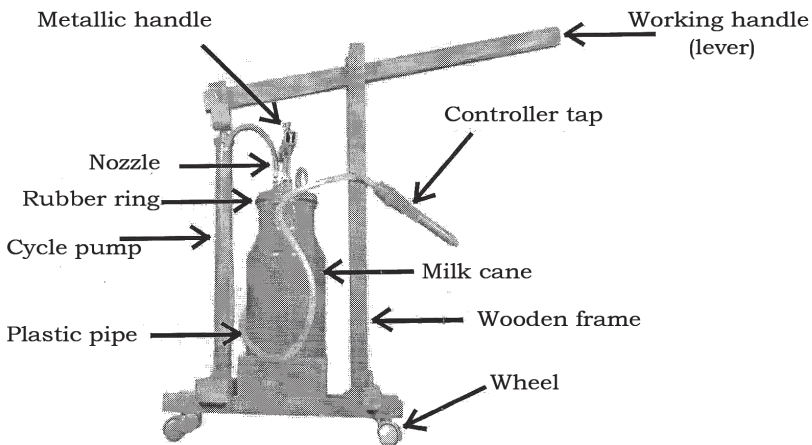

Fig. 1: Mini vacuum cleaner

MATERIAL REQUIRED

Milk cane container (5litres) with handle at the top, a cycle pump set (reverse function), a small spring with metallic sphere, plastic pipe (1 cm diameter) with controller tap; wooden frame with working handle (lever), a rubber ring; a cycle tube nozzle, and four wheels.

CONSTRUCTION AND WORKING

The tank (Milk cane 5 litres) is fitted with 2 nozzles and a handle with air tight. One nozzle is connected by a pipe from the pump with screw and another nozzle is fitted with a plastic pipe (1 cm in diameter) with controller tap. The top of the cycle pump is fitted with a working handle (lever). The tank and pump are fixed with a wooden frame including the wheels at the bottom. By pressing the working handle, the upward reverse the function of the pump to the milk cane (tank) and it sucks out all air from it. When the controller tap is on, air from outside starts flow towards the vacuum inside the tank with small dust particles. Thus, the cleaner works.

APPLICATIONS

- It is free from any electrical energy.
- It can be used as vacuum cleaner in our home.
- It can save us from harmful dust particles.
- It can be used for cleaning the corner of sofa/cushion.
- It is a low cost.

6

MULTI-PURPOSE UNIT FOR FARMER

STUDENTS

Rutuja Vilas Jadhav,
Samya Rajendra Korde
Pratik Vijay Gaikwad
Aditya Mallinath Narayankar

Shiv Shikshan Sanstha's
Dharmaprakash
Sreenivasiah High School,
Scheme-6, Road No-
24C, Sion (W), Mumbai,
Maharashtra

TEACHERS

Adesh Arun Patil
Arvind Dashrath Jadhav

INTRODUCTION

India is called agricultural country. Still today more than half of Indian's population is dependent on agriculture. But really are our Farmer happy? At least once in a week we see farmer's suicide news. Why? What he gets by working so hard? Today younger generation don't show interest in agriculture because of traditional methods of farming giving less income and more physical labor involve.

Study says, America and China get more than enough income from agriculture though limited land are available for cultivation and is because of using advanced technologies in agriculture. But farmers in our country cannot afford these highly advanced technologies due to poverty and geographical conditions.

So to attract our youngsters towards agriculture and to decrease physical labour of farmers. We have invented "Multi-purpose Unit for Farmer".

SCIENTIFIC PRINCIPLE INVOLVED

Energy can neither be created nor destroyed. It can be converted from one form to another. The total energy in the universe always remains constant.

MATERIAL REQUIRED

Flywheel dia 26"; cycle chain sprocket; cycle sheet; cycle break; eight pulleys with dia 18", 6", 4", 4", 10", 4", 10", 2"; alternator; bulb 12V; battery (12V, 2.25A); wires pine 2½ft and grey outlet pipe 7 ft; thresher; 4 V-Belts 78, 53, 44, 53; axle; nut-bolts etc.



Fig. 1: Multi-purpose unit for farmer

CONSTRUCTION

We have made fly-wheel (dia 26") for smooth functioning of the unit. The pulley dia 18" adjacent to flywheel is connected to front pulley dia 6" to it via V-belt 78. On the same axle there are another three pulleys having dia 4", 4" and 10".

The pulley (dia 4") on the extreme left of the axle is connected to thresher pulley also having dia 4" via V-belt 53. Another pulley on the axle with dia 4" is connected to sprayer pulley dia 10" by V-belt 44. And the pulley on extreme right of the axle dia 10" is connected to alternator pulley dia 2" by V-belt 53.

All parts of the Unit-Thresher, Blower, Sprayer, Alternator, Flywheel, Axle are joined by nut-bolts.

WORKING

Working is based on Cycling:

- i) For paddy threshing, we have got rpm 350-360. All grain from the stalk threshed easily.
- ii) After threshing to obtain clean grain, blower had been made. During cycling, thresher gets rpm 360 and generates air. This air comes out of blower and help the farmer to get clean grain.
- iii) During spraying pesticides we have got rpm 144, pesticides come inside the piston pump and piston pushes them out by pressure.
- iv) During all above three process electricity is generated by alternator and it get stored in battery. We got alternator's rpm 1800.

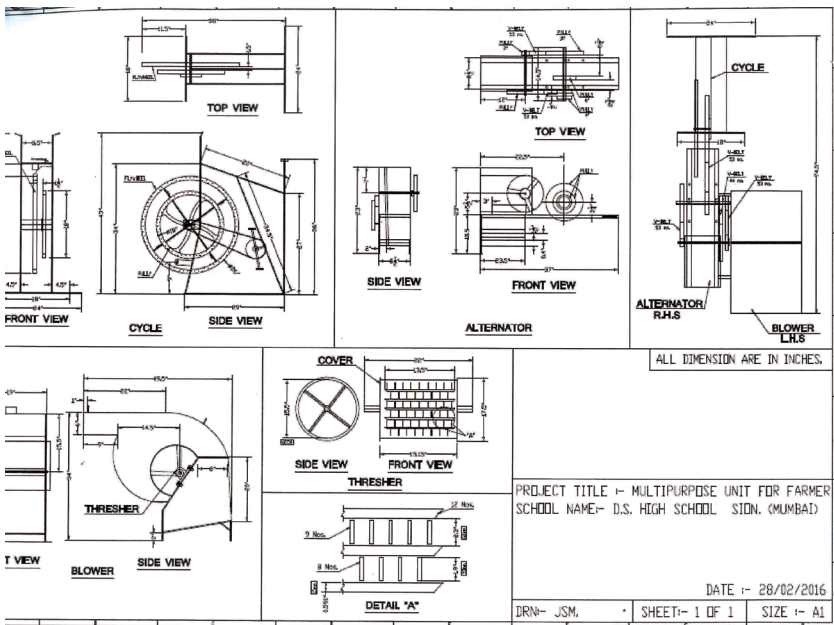

Fig. 2. Design of the project (Unit)

EFFICIENCY

- Farmer can obtain 150 kg of grain in 1 hr.
- Half hectare area can be covered in 1 hr during spraying pesticides.
- 12 V bulb glows during cycling.

APPLICATIONS

- i) Eco-Friendly.
- ii) Easy handling.
- iii) Durable.
- iv) Minimises labour wages.
- v) Minimises physical labour of farmer.
- vi) In paddy threshing farmer gets 100 per cent grain.
- vii) For blowing grain, no need to wait for wind.
- viii) Stored electricity can be used for glowing bulb and mobile charging etc.
- ix) Helps to maintain fitness.

SIMPLE SEED SOWER

STUDENT

Thokchom Jameson Singh

Ananda Purna School,
Thoubal Tomjing
Makhong, Thoubal,
Manipur**TEACHER**S. Swaminath

INTRODUCTION

In the traditional method, most of the farmers scatter the seeds of the plants randomly by using power tractors. In such phenomenon, some of the seeds are not be able to germinate due to more depth or leaving the seeds on the surface of the soil. In this situation, seeds are spoiled, about 10 per cent on the surface and 20 per cent in depth (altogether 30 per cent) of the soil unnecessarily. In view of this, a new model 'simple seed sower' is developed to avoid such loses and also to enable maximum seeds to germinate.

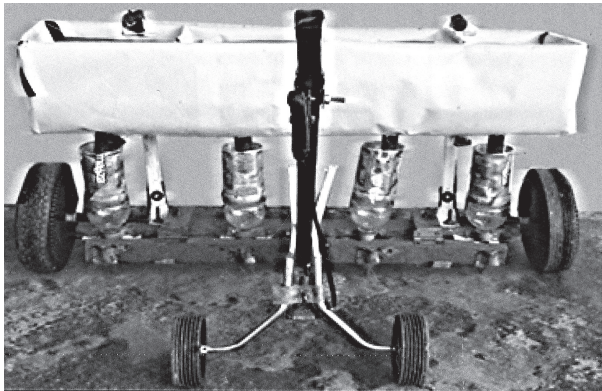

Fig. 1: Simple seed sower

SCIENTIFIC PRINCIPLE INVOLVED

The model 'Simple Seed Sower' is based on the scientific principle of levers.

MATERIAL REQUIRED

Cuboid iron pipe, seed containers (plastic bottles), plastic wheels (four), binding wire; bolts and nuts; cycle brake with cable string; wood; plastic covering and seed gun.



Fig. 2: Seed container with sower frame



Fig. 3: Seed storage container

CONSTRUCTION AND WORKING

Two plastic wheels are made to support the seed containers at two ends of a wooden frame, four ploughs are fixed on the wooden frame attached to a straight cuboid iron pipe so as to put the seeds in the soil. Four iron rectangular plain sheets of same sizes are fixed behind the wooden frame of each ploughs, four seed guns are also attached to the wooden frame respectively. A depth analogue indicator consisting of two small plastic wheels are fixed and attached to the handle. A large seed storage having four chambers is fixed above the four pipes. This seed storage is fixed to the wooden frame by using two iron rods.

The 'Simple Seed Sower' is ready for seed sowing and can put the seeds regularly in its appropriate depths after adjusting the depth analogue indicator.

Since, seeds are of different sizes, one can drop the seed from four seed containers. When we hold the cycle brake, each seed

gun inserts seed one by one from four seed containers as the four ploughs dig the soil simultaneously.

Then, the dropped seeds coming from the large seed storage having four chambers are in the soil, the iron plain sheets which are fixed behind the ploughs enable to cover the seeds gently. Thus, one can sow the seeds in the field.

ADVANTAGES

- i) By using “Simple Seed Sower” any farmer can sow seeds at a suitable depth for maximum germination.
- ii) This machine can save nearly 30 per cent of seeds which are going to be spoiled.
- iii) With the help of Simple Seed Sower, farmer’s crops productivity can be increased.
- iv) This machine can give a great impact to the farmer’s economy.

JUGAD TECHNOLOGY IN AGRICULTURE

STUDENTS

Jaskaran Singh
Harjot Kaur

Government High School,
Madhir, Sri Muktsar
Sahib, Punjab

TEACHER

Kamal Jeet

INTRODUCTION

As we know in the modern era, agriculture increasingly depends upon the bigger and bigger machines. These machines use huge amount of fuel as well as the cost of these machines is very high and it beyond the reach of a farmer having small agricultural lands.

We have designed a hand driven multi-purpose machine that can be used in agricultural practices and the special features include replaceable of parts; hand driven mechanism; portability; and low cost. This machine does not need petroleum and can be used for any type of soil.

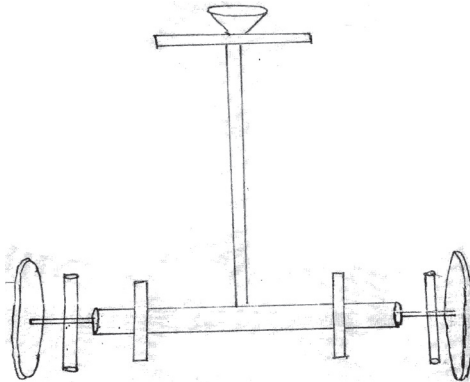

Fig. 1: Seed drill

SEED DRILL

A seed drill is a sowing device made up of two PVC pipes. The pipes revolve around the axis with movement of hand machine. The seeds present in the pipe comes out through the pores and

fell down in the furrow formed by the blades present at the anterior ends of machine. This seed drill sows the seeds at equal distances and proper depth.

CONSTRUCTION

Axis is attached to wheels through the ball bearing fitted in the side of steel tube. The tube is welded with long nuts on its sides. Steel tube is fitted with T-shaped pipe to pull or push the machine.

MATERIAL REQUIRED

Two large wheels, steel axis, steel pipe, nuts fitted with steel pipe, small leveller fitted with bolt, small plough fitted with bolts, handle, funnel, and a disk.

BROADCAST SEEDER

Small seeds like seeds of mustered, rye linseed ect, are sown with the help of hands and are sown unevenly that reduces the yield up to a great extent. So we have designed a broadcast seeder in this multi-purpose machine, this broadcast seeder is made up of a D.C. motor attached with a disc on its axis. When the axis of motor moves, the disc also rotates and the minute seeds fell on this disc and thrown at fixed distance.

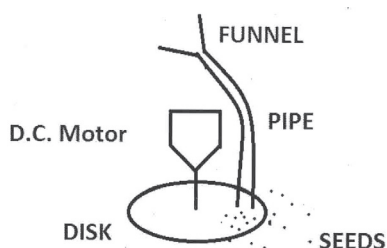

Fig. 2: Fertilizer spreader

FERTILISER SPREADER

Fertilisers are added to the soil with the help of hands thus these are spread unevenly that reduces the yield up to a great extent. So we have designed a fertiliser spreader in this multi-purpose machine, this fertiliser spreader is made up of a D.C. motor attached with a disc on its axis. When the axis of motor moves the disc also rotates the minute fertilisers and it fell on this disc and are thrown at fixed distance.

PLOUGH

A large farming implement with one or more blades fixed to the steel pipe with the help of nuts and bolts, drawn over soil to turn it over and cut furrows in preparation the planting of seeds.

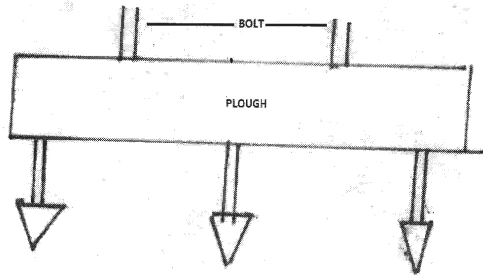

Fig. 3: Plough

LEVELLER

Leveller is a long iron blade attached to the steel pipe with the help of nuts and bolts. Leveller is used for smoothing of the land and creaking the soil crumbs to improve the surface of land.

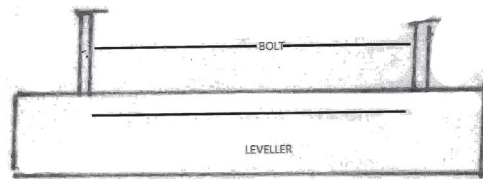

Fig. 4: Leveller

HANDY SEED DRILL

With the help of this seed drill we can sowed large size seeds. This seed drill is made up of clutch wire, seed size controller, two funnels.

When we have to sow seeds, in the first funnel we add the seeds and in the second funnel we add the fertilizers. When the clutch is pressed seed will pass from the pipe and the valve present at its terminal end will open. The seed will fell down in the trench formed by the drill.

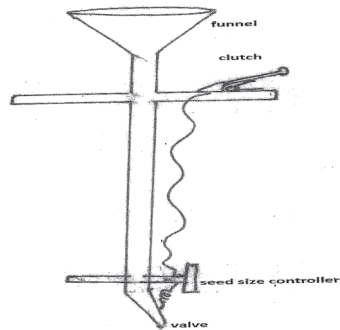

Fig. 5: Handy seed drill

In this way we can sow large seeds at proper space and proper depth.

BICYCLE BASED EQUIPMENT FOR AGRICULTURE

STUDENTS

Pratyush Bisen
Himanshu Ranjan

Bharatiya Vidya Bhavan's
B.P. Vidya Mandir, Ashti
(Khurd), P.O. Walni.
Nagpur, Maharashtra

TEACHER

Samir M. Khule

INTRODUCTION

India is an agricultural country and around 70 per cent of the population is directly dependent upon farming and farm based activities. But due to problems like unavailability of labour, lack of rainfall and frequent power cuts, they cannot produce much harvest. Less harvest means less profit. So, the farmer cannot pay his debt and is thrown into a vicious cycle, and may even commits suicides. This enables us to develop something to help the farmers with the help of science. The aim of our model is to develop a device to perform works like drawing water from well; generating electricity and charging a rechargeable cells; and crop cutting by just peddling the bicycle.

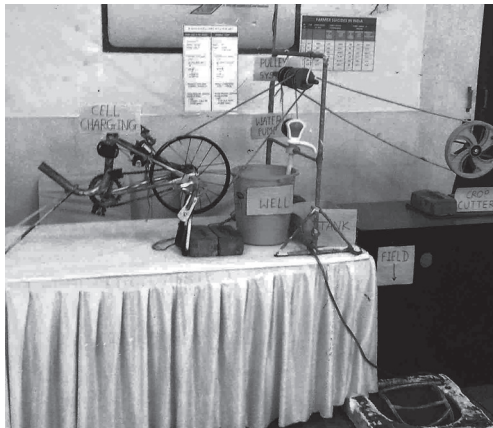

Fig. 1: Bicycle based equipment

Here muscular energy is used to do mechanical work (agricultural work) using friction and tension between wheel-rope and wheel-pulley. The rotation of pulley system allows crop cutting and simultaneously creates air pressure inside the pump to lift water. Again muscular energy is converted into electrical energy using dynamo which works on the principle of electromagnetic induction.

MATERIAL REQUIRED

A bicycle, pulley system with iron stand, bucket, a pressure water pump, dynamo, lights, rechargeable battery for storage of electricity, pipes, thermocol sheet, wheel and small plastic tank, etc.

CONSTRUCTION AND WORKING

This bicycle has three main components namely; i) wheel ii) axle mechanism iii) pulley. The rear wheel is connected to the pulley by a rope. This pulley is connected with crop cutter and pressure water pump. A dynamo is placed near the wheel.

FARMER SUICIDES IN INDIA							
SR. NO.	YEAR	FARMER SUICIDES IN INDIA	FARMER SUICIDES IN MAHARASHTRA		FARMER SUICIDES IN VIDARBHHA		
			NUMBER OF FARMER SUICIDES	PERCENTAGE (FROM INDIA)	NUMBER OF FARMER SUICIDES	PERCENTAGE (FROM INDIA)	PERCENTAGE (FROM MAHARASHTRA)
1	2010	15884	3141	19.67%	748	4.6 %	23.8%
2	2011	14027	3337	23.78 %	918	6.5 %	27.5 %
3	2012	13754	3786	23.50 %	916	6.6 %	24.1 %
4	2013	11772	3146	26.78%	718	6.1 %	22.8%
5	2014	12360	2568	20.776 %	1072	8.6%	41.7%
6	2015	13117	3228	24.61 %	926	6.2 %	25.5%

Fig. 2: Farmer suicides in India

As the wheel rotates, it makes the pulley to rotate which in turn creates a pressure in the pump to draws the water from the well. This water will be stored in the tank and used for drip irrigation through pipes. The pulley is connected to the cutter with the help of another rope. Here also, as the wheel rotates, the pulley rotates which in turn makes the cutter to turn which can be utilised to cut crops and fodder. The dynamo is attached to the rear wheel. As the rear wheel rotates, the dynamo turns and produces electricity by the phenomenon of electromagnetic induction. The electricity can be used at night and can also be used for charging batteries (storage of electricity) and other purposes.

DESCRIPTION OF PUMP USED

For the small pump used in the model: For every rotation of wheel a human requires a energy of 0.53 joule to peddle the bicycle to lift 0.016 L water per rotation.

For the larger pump: For every rotation of wheel a human requires a energy of 144.85 joule to peddle the bicycle to lift 3 L water per rotation.

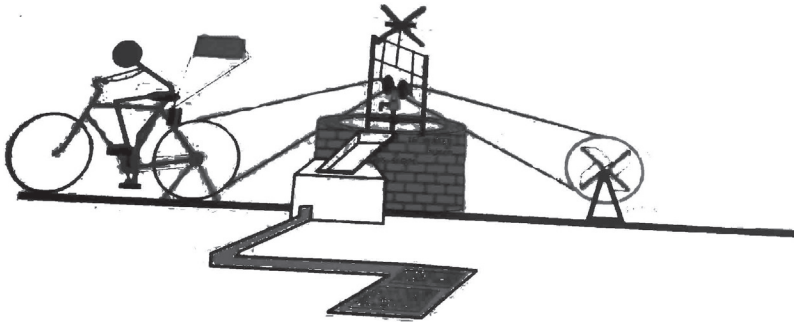

Fig. 3: Description of pump used

APPLICATIONS

- i) Crop cutting.
- ii) Lifting water from well by using pressure water pump for irrigation.
- iii) Generation of electrical energy by principle of Electromagnetic Induction.
- iv) Storage of electricity (charging battery, rechargeable cell etc.)

SOLAR WEEDER

STUDENT

Moirangthem Somia Devi

Kakching Higher

Secondary

School, Kakching

Chumnang, Thoubal,

Manipur

TEACHER

P. Sarju Singh

INTRODUCTION

India is an agricultural country. The progress in agriculture today in the country is mainly due to the aid of new scientific researches and adoption scientifically oriented agricultural implements. The work in the field such as weeding, ploughing, sowing, reaping and threshing etc. are being done by sophisticated machines. In this exhibit, we present solar weeder machine for weeding.

SCIENTIFIC PRINCIPLE INVOLVED

The scientific principle of this model is based on the conservation of energy, i.e. "Energy can be transformed into another forms of energy but cannot be destroyed". The electrical energy is converted into mechanical energy and the motion of the weeder is used in cleaning the weeds in the paddy field.

Mathematical relation between weeder wheel and smaller pulley is 5:1

$$\left(\frac{\text{circumference of larger pulley}}{\text{circumference of smaller pulley}} = \frac{2\pi r_1}{2\pi r_2} \right)$$

MATERIAL REQUIRED

Old weeder machine, a 12 V electric D.C. motor, a 12 V storage battery, Solar panels, and a weeder disc.

CONSTRUCTION AND WORKING

We collected an old weeder machine from scrap iron shop and redesigned the machine and fixed a D.C. motor of 12 V on the weeder machine and a storage battery of 12 V. Then we collected solar panel from scrap electronic servicing centre.

The solar panels are arranged in series and parallel connection for increasing voltage and current. The panels are fixed on the farmer/cultivator shirt. The pulley of the electric motor is connected to the weeder wheel by a belt.

When we switch on the motor, the motor starts working and rotated the pulley which is connected to the weeder wheel. The weeder wheel touches the paddy field and softened the paddy field thereby cleaning the weeds from the field.

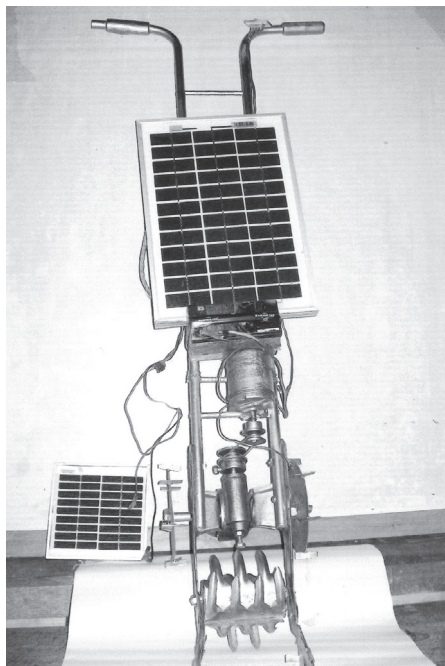

Fig. 1: Solar weeder

APPLICATIONS

A farmer can make this machine at his/her own initiative as it is a simple technology and can be constructed by collecting locally available materials and a few other parts at low cost. The machine can do weeding and cleansed the paddy field very fast. It also saves precious time and increases efficiency in the field of agriculture and saves human energy.

MULTITASKING AGRICULTURAL MACHINE

STUDENTS

Gauri Dhaku Mestry
Vikas Vijay Lingayat

Pragat Vidyamandir
Ramgad, Malvan,
Sindhudurg,
Maharashtra

TEACHER

Mahadev Pundalik Pawar

INTRODUCTION

India is known for agricultural country in the whole world. The main occupation of people in villages is agriculture. Village people in our country also do various other occupation parallel to agriculture such as animal husbandry, production of milk products, selling tender coconuts etc.

From these occupations farmer not only improves his/her economic condition but also improves his/her knowledge about agriculture. Similarly, housewives, hotel owners need various devices while working. So, we invented a "Multitasking Agriculture Machine" which can be easily used by all these people and is inexpensive. This machine includes interesting 11 parts.

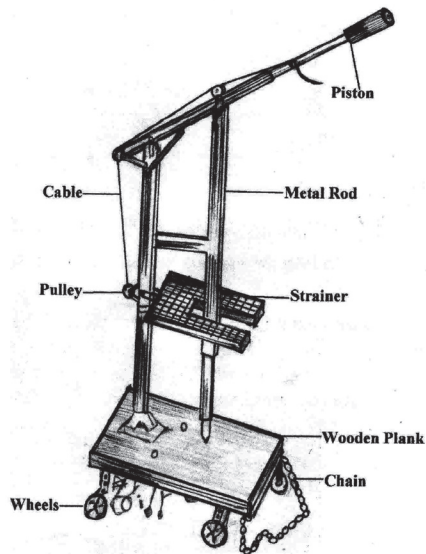

Fig. 1: Multitasking agriculture machine

SCIENTIFIC PRINCIPLE INVOLVED

Use of levers in every day life.

MATERIAL REQUIRED

Wooden plank, metal rod, spring, wheels, pulley, nut bolts, hinge, iron net, wooden strips, cable, and metal strips.

CONSTRUCTION AND WORKING

Firstly, we prepared a stand by welding the metal strips. Fixed wooden plank on stand with screws and a metal rod on wooden plank. Thereafter, we placed two rods in each other and joined it to metal rod and also fit nut-bolt to these rod. Rod to make hole in tender coconut, machine of grating coconut, juice extracting machine, curd churning device, cutter, cashew cutter, spraying machine can be fitted to perform their task. Similarly, other tasks such as ploughing, sowing seed and covering land with soil, weeding arrangement is done at bottom of machine. These arrangements of machines performs various tasks as needed.

(i) Machine to Make Hole in Tender Coconut

To get coconut water from coconut we prepared device as below. A metal rod pointed at bottom and joined with screw. This metal rod is joined to piston and we can place tender coconut below machine on a metal stand. When we press this piston, the metal rod pushes into tender coconut and makes hole in it, thus we can easily get coconut water from it.

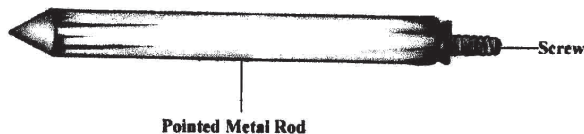

Fig. 2: Machine to make hole

(ii) Peeling Off Cover of Tender Coconut

After we get coconut water from tender coconut we peel off the cover of coconut to get kernel.

We prepared a device that can peel off the coconut cover. We joined two small metal parts pointed like spear on a metal sheet and joint a rod to it. When we bump coconut on these spear and pull the rod upward the cover of coconut is peeled. In this way we can peel off coconut cover quickly without any injury.

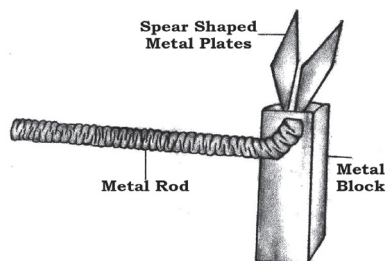

Fig. 3: Peeling off cover

(iii) Rating Coconut Kernel

There are different equipment's in market to grate the coconut but they should be used properly.

We prepared device with the help of metal blade to grate coconut on same machine and fixed blade in the hole of piston

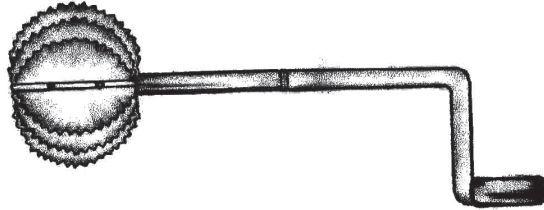

Fig. 4: Rating coconut kernel

and also have inserted the screw above this hole so that blade gets proper support. As we turn round these blade, we can very easily grate the coconut. Not only women can do, but also men can do this work easily.

(iv) Curd Churning Machine

Generally we use churning rod to churn the curd, but we need more efforts. So, we prepared a device as given below. We have fixed a screw at upper side of pressing churning rod and join it to piston in the machine. We have placed curd on the stand under the machine. Whenever we press the piston down, the churning rod deeps in the curd and starts churning. Therefore, we don't have to take efforts and can also finish work quickly.

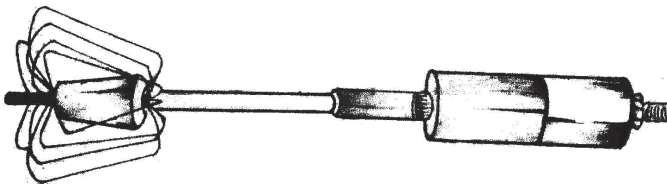

Fig. 5: Curd churning machine

(v) Juice Extraction Machine

In this equipment we have separated both parts of juice extracting device. Cutting some upper part we fixed screw in

it and now we can join these screw to piston. Similarly, in the downward part we have curved shape on plank and fitted to hold glass below these plank.

When we press piston, the lemon between these equipment is properly pressed and we can easily extract complete juice from it. Therefore we can extract juice of lemon, orange, sweet lemon, mango and apple very easily.

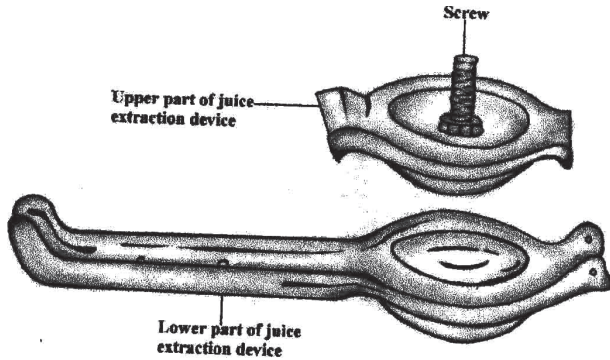

Fig. 6: Juice extraction machine

(vi) Cutter

We have made a cutter to cut vegetables and fruits in these machine. We used a metal blade and we have sharpen one side of this blade. We also, made a hole at one side and placed screw in it. We have to join one screw to piston and join the screw on machine to another hole of blade.

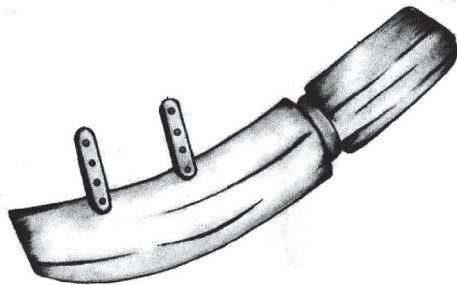

Fig. 7: Cutter

(vii) Cashew Cutter

Nowadays, cashew cutters are available in market but the height of this device is up to our chest and it has to be pressed with legs. So, we have prepared a cashew cutter here as shown in diagram below.

In this cashew cutter, to cut cashew we have to place cashew between the plates and press piston, thereby both plates

of cashew cutter come together and cashew easily cuts. To remove cashew from cashew nut pull the other piston. Using this method we can easily cut cashew nut.

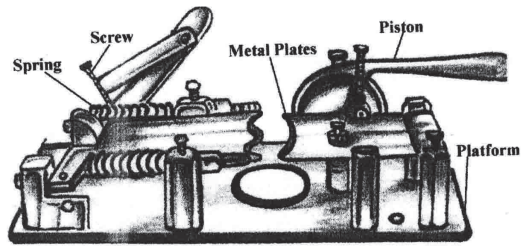

Fig. 8: Cashew cutter

(viii) Sifting Machine

Here, we have prepared a strainer by making wooden strips together and fixed it to machine by welding. Accordingly, the strainer is joined with cable and with help of pulley it is joined to piston. When we move this piston up and down, the strainer moves forward and backward and the pulses and grains in this strainer are shifted and dusts or wastes from it is separated.

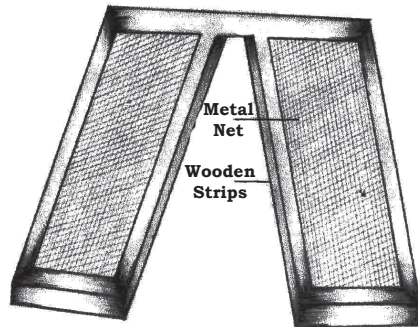

Fig. 9: Sifting machine

(ix) Ploughing, Showing Seeds and Covering Again with Soil

We have joined plough furrow at lower side of machine, also made arrangement for hinge and joined a pipe backside of plough furrow so that seeds fall on ploughed land. We have also joined a wooden plank with the help of hinge at backside of machine. At lower side of machine, wheels are fixed and in front side there is

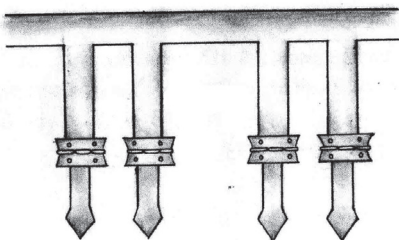

Fig. 10: Plough furrow

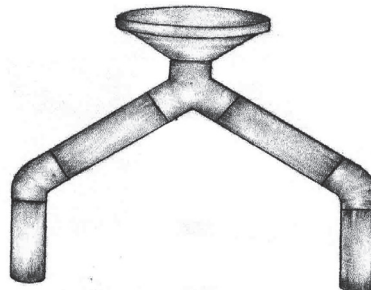

Fig. 11: Equipment to sow seed

chain so that we can easily pull this machine. Now we can see that how land is ploughed with plough furrow, seeds fall in one direction and wooden plank cover the land with soil again. At a time these 3 works are being done and as plough furrow has hinge it can be folded when no need.

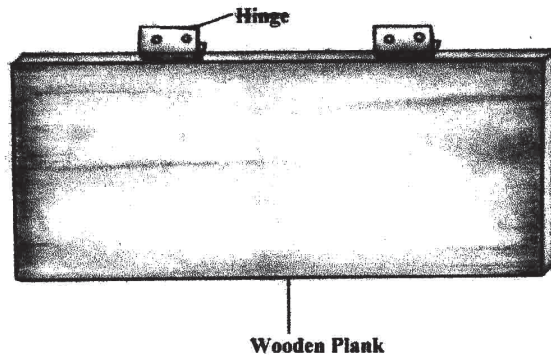

Fig. 12: Wooden plank to cover land again with soil

(x) Weeding Machine

To prepare this machine we used a metal hollow rod and fixed metal rod on both sides and fixed screws on all sides of rod. Moreover hinge is joined to this weeding machine and fixed these arrangement at bottom of machine.

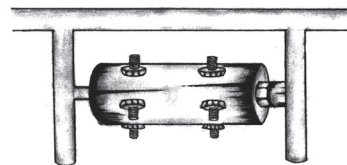

Fig. 13: Weeding machine

When we pull machine with the help of chain, weeding machine starts moving and weeds are removed with the help of screws. In this ways weeds can be removed from the field very easily.

(xi) Spraying Machine

We have placed two metal rods one in one. One rod is joined with pipe inserted in insecticides and the other rod is joined to pipe with spout and the pump is joined to piston with screw. When

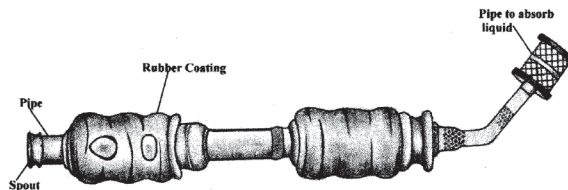

Fig. 14: Spraying machine

we pull the piston up and down, insecticides or water enter in the pipe and comes out through spout.

With the help of this pump we can spray insecticides in fields and farms.

APPLICATIONS

- i) We can easily get coconut water from tender coconut.
- ii) We can remove the cover of coconut in less time.
- iii) We can completely extract juice from fruits like lemon and orange.
- iv) We can churn curd and get buttermilk in less time.
- v) There is no risk of getting injured while grating coconut or cutting vegetables.
- vi) We can easily remove weed from farm.
- vii) Easily we can cut cashew with these machine.
- viii) We can easily spray insecticides or pesticides in field.
- ix) One person can easily handle these machine.
- x) We can easily move machine from one place to another.
- xi) It is also useful in hotels and also for housewives.

INSTRUMENT FOR CLIMBING ON THE POLE

STUDENT

Swapnil Subhash Sulunkhe

Awali High School,
Awali, Atpadi, Sangli,
Maharashtra**TEACHER**

Hegade Balu Yashwant

INTRODUCTION

Electricians have to climb on iron poles or cement poles for their duties. It is the most troublesome. If they are overweight, they are unable to climb on the pole easily. Due to tempest or cyclones during rainy season, the electric line gets faulty. The electricians often have to climb on the poles to find out the fault. The instrument that we have prepared will be useful for all the electricians appointed for the task. Due to this instrument they can climb on the poles without any trouble. They can complete their task without getting tired.

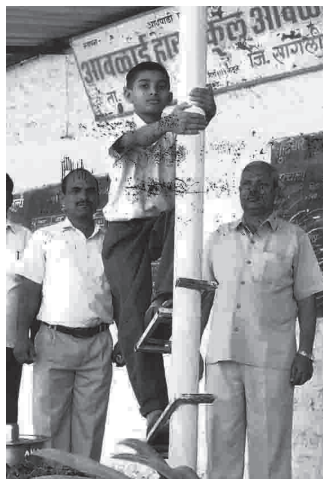

Fig.1: Climbing on pole

SCIENTIFIC PRINCIPLE INVOLVED

It works on the principle of Class I Lever. Fulcrum is placed between the effort and load. The load on one side is balanced by stationary pole.

MATERIAL REQUIRED

A four feet long (having a 0.75 square inch cross-section) pipe; two inch long four nut-bolts; and a pair of shoes.

CONSTRUCTION

First of all we have to cut pieces of requires size of square pipe for constructive the structure shown in the picture. Then these are to be welded. Afterwards we can fit slippers on this structure with the help of nut-bolts. Now our instruments is really for use.

FEATURES

- i) The cost is about ₹ 300.
- ii) It can be developed easily.
- iii) It can create employing opportunities.
- iv) The same instrument can be prepared for climbing the taller coconut trees etc.

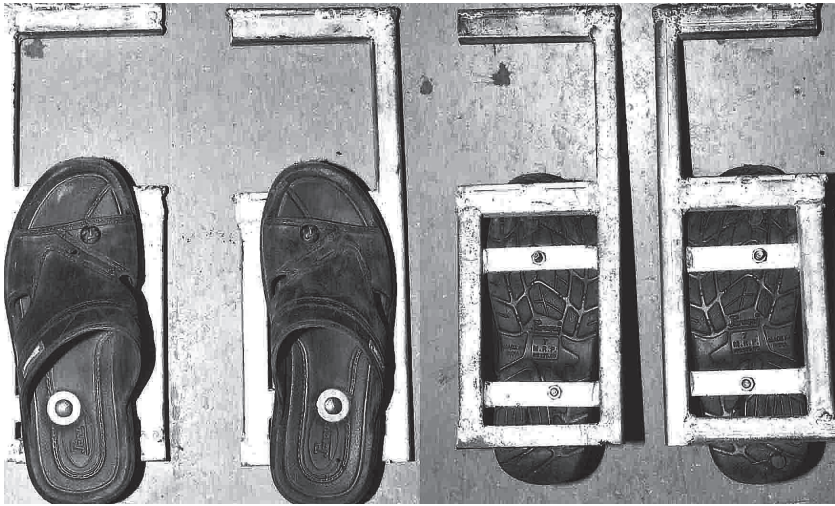

Fig. 2: Instrument for climbing on pole

APPLICATIONS

This instrument appears so simple but it is very useful not only for electricians but also for farmers to climb on the pole or coconut trees.

SOLAR MIXER MACHINE

STUDENT

Sweeta Thokchom

St. Mary's
High School,
Churachandpur,
Manipur**TEACHER**K. Meghachandra Singh

INTRODUCTION

Now a days there is limitation of sources of energy due to increase of human population and limitation of fossil fuels. The fossil fuel available on earth become more and more limited as crude oil from the earth is drawn out in million tonnes every day. We started using renewable source of energy like wind energy from running water, solar energy etc. The small force generated can be upgraded and the power can be increased several times by using gear wheel pulley systems of Archimedes and Pascal's law.

SCIENTIFIC PRINCIPLE INVOLVED

The small electrical energy produced by solar energy can be converted into big mechanical energy to perform useful work.

MATERIAL REQUIRED

An aluminium pot of five inch diameter, four plastic gear wheels, a tap record fly wheel, a thick wooden plank of 10 inches \times 6 inches \times 1½ inches, two pieces of wood of size ½ inches \times 2 inches \times 6 inches, a 1½ inches \times 2 mm \times 2 ft tin sheet, a 3 V electric D.C. motor, a set of battery clamps, a 3 V rechargeable battery, two 6 mL syringes and an IV set, a 6 V solar panel, four No. 8 nut bolt, flexible insulated copper wire-4 m, Some 1½ inches iron nails.

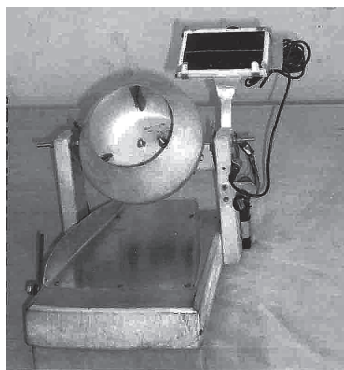

Fig. 1: Solar mixer machine

CONSTRUCTION AND WORKING

A thickened wooden plank of 10 inches × 6 inches × 1½ inches is taken as platform. The two pieces of wood of ½ inches × 2 inches × 6 inches are vertically fixed from both the sides of the plank. The 4 gear wheels of different sized are fixed in a piece of iron plate along with the 3 V D.C. motor, so that, the last gear wheel rotate one time when the motor rotate 30 times.

SOLAR MIXING MACHINE

MAIN THEME: SCIENCE AND
MATHEMATICS FOR INCLUSIVE
DEVELOPMENT
SUB THEME: RESOURCE
MANAGEMENT

NAME OF THE EXHIBITOR :
THOKCHOM SWEI & DEVI (CLASS 9)
NAME OF THE TEACHER GUIDE :
K. MEGHACJANDRA SINGH (B.Sc, B.Ed)
NAME OF THE SCHOOL :
ST. MARY'S HIGH SCHOOL, CHURACHANDPUR

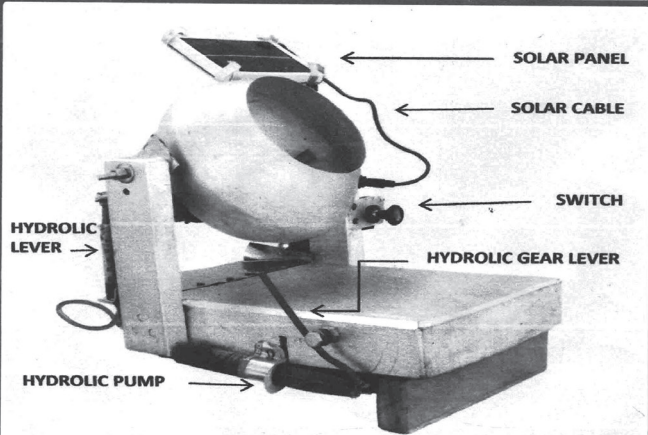
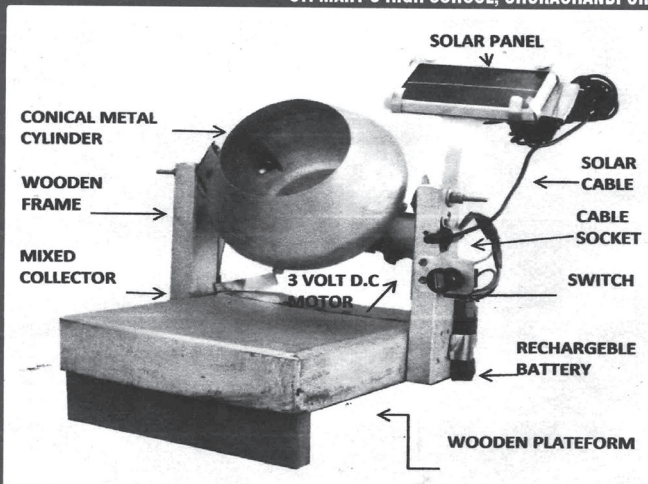

Fig. 2: Solar mixer machine

An aluminium pot of 5 inches diameter is fixed on the last plate gear wheel with the help of a tape record fly wheel. The whole set is fixed at the centre of two vertical or perpendicular wooden pieces so that it can move up and down the pot to pour out the mixing materials with the help of a hydraulic syringe pump. Solar cell and rechargeable battery are connected to the motor with the help of a switch.

The solar cell converts the light energy into electrical energy. The electrical energy stored in the battery is converted into mechanical energy by an electric 3 V motor. The motor is connected to the mixer through 4 different size gear wheel. Aluminium pot fixed on the last gear wheel rotates one time when the motor-axle rotates 30 times. The different material put inside the pot is mixed up by rotation of the pot and pouring out of the homogeneously mixed materials with the help of hydraulic syringes fixed at the side of the plate form.

ECO-FRIENDLY PLASTIC

STUDENTS

Sumana Biswas
Subhasrt Datta

Dhubulia Subhas
Chandra Balika
Vidyalaya, Nadia,
West Bengal

TEACHERS

Rajasree Ghosh
Mili Nath (Biswas)

INTRODUCTION

Plastic is the most widely use material in our day to day life. The conventional plastic that we use is most biodegradable and pollutes the environment. To solve the problem an eco-friendly plastic has been developed.

SCIENTIFIC PRINCIPLE INVOLVED

Starch (cornflower) reacts with acetic acid (vinegar) at 60–80°C and starch acetate is formed. Then glycerine is added to the mixture to obtain an eco-friendly plastic material.

MATERIALS REQUIRED

Cornflower, vinegar, glycerine, water, and an aluminium foil.

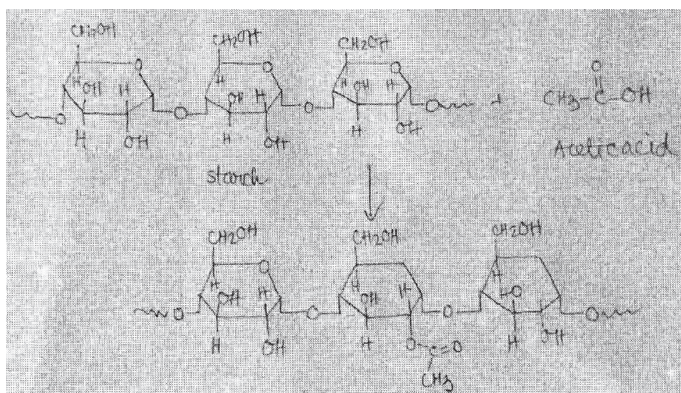
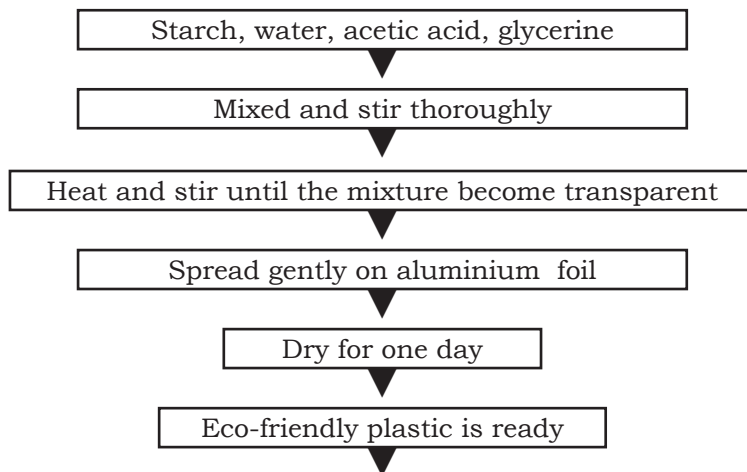

Fig. 1: Starch acetate

WORKING

Cornflower and water are mixed in 1:4 ratio. Then glycerine is added and mixture is stirred thoroughly. The whole mixture is heated to 60–80°C temperature. At such a temperature the mixture become transparent. The transparent mixture is spread on aluminium foil and allowed to dry for about one day. Then it is separated from the aluminium foil. Eco-friendly plastic is prepared.



APPLICATIONS

This mechanism is useful in preparing non-toxic biodegradable house-hold plastic equipments, plastic bags, and different non-toxic toys.

REFERENCES

- i) *Organic Chemistry* by A. L. Finar.
- ii) *Introduction to Organic Chemistry* by Wiley.
- iii) 'Starch-Vegetable fibre composites to produce products', carbohydrate polymer by Fama L, Gerschenson L, Goyanes, @2009, *Science Journal*.
- iv) *Science Experiments* by Robert whinstone.

AUTOMATIC STREET LIGHT

STUDENTS

Souvik Dey
Suvojit Halder

Sahapur Harendranath
Vidyapith (H.S.),
Kolkata,
West Bengal

TEACHER

Saikat Basu

INTRODUCTION

The conventional sources of energy (i.e. fossil fuels) are limited and will get exhausted with the time. We need energy mostly in the form of electricity. Ministry of power, Government of India reports that 22 – 25 per cent of total electricity consumption in India accounts for lighting (Ministry of Power (2010), The Economic case to stimulate LED lighting in India) Lighting accounts for nearly 6 per cent of global CO₂ greenhouse gas emission. A significant part of lighting is attributed to street light which sometimes is the largest expenditure of many urban local bodies (Municipalities, Municipal Corporations etc.).

The need of the hour is judicious use of energy and opting for energy efficient lighting technologies. Using LEDs in place of conventional street lights can cut CO₂ emissions by 50 per cent to 70 per cent and consume at least 50 per cent lesser electricity than conventional street lights, which thus saves both energy and money.

We have prepared a working model where LEDs have been used as street lights. We have made use of LDRs (Light Dependent Resistors) and transistors for automatic control (on/off) of the street lights in place of timer circuits or manual operations. This ensures lighting only when required. Thus it avoids wastage of energy.

The main focus of our working model is to incorporate a vehicle dependent brightness control system that generates full brightness from the LEDs on detecting a vehicle movement, otherwise minimal brightness level would be maintained when there is no vehicle movement. This saves a lot of electricity consumption at non-peak hours (late at night to dawn).

high enough to bring the transistor 1 in its saturation region. Now the transistor 1 acts as a closed switch and switches on the LED.

Left side of Fig. 2 shows the additional circuit for vehicle dependent brightness control arrangement that is used for enhancing and dimming the brightness of LED at non-peak hours. Light from a laser torch keeps falling on LDR₂ which lower the resistance and hence low voltage keeps the transistor 2 in switched off state. Whenever a moving vehicle comes in between the laser torch and LDR₂, it intercepts the light signal. Automatically, the sudden rise in voltage drop across LDR₂ switches on the transistor 2, which instantaneously enhances the brightness level of LED. This ensures sufficient bright light just in front of the vehicle for safe driving. Once the vehicle moves ahead, the laser-LDR₂ light is restored. Thus the voltage drop across LDR₂ falls significantly and once again makes the transistor 2 switched off. This results in dimming of LED. The laser-LDR₂ arrangement is kept in between consecutive lamp posts.

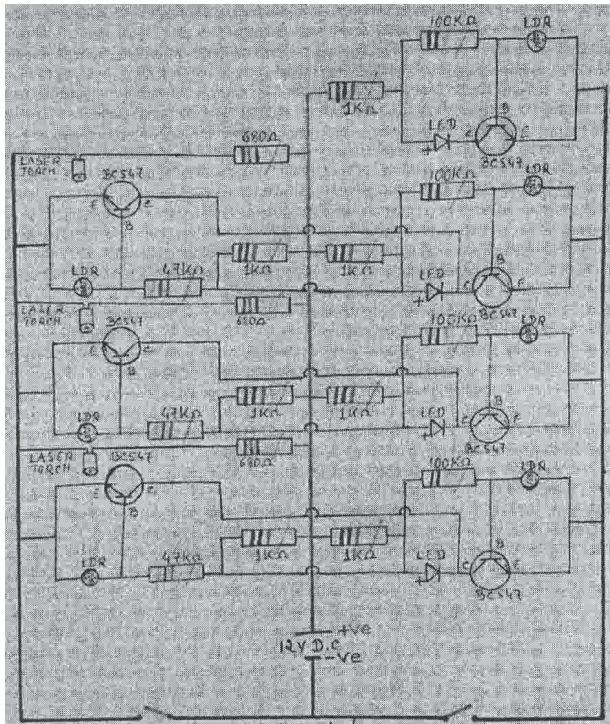

Fig. 2: Complete circuit diagram

CONCLUSION

Our circuit ensures automatic off/on of the street lights depending on the brightness level of the ambient light. This reduces energy consumption to a large scale. Existing timer circuit or manual operations of street lights do not detect the ambient light level and huge wastage of electrical energy is incurred thereby.

The incorporation of vehicle dependent brightness control arrangement in our model further avoids wastage of electrical energy at non-peak hours by auto dimming and enhancing the brightness level of LEDs as stated before. Our circuit is very simple, cost effective and components used are easily available. The Municipal Corporations can implement this concept through pilot project to ascertain and confirm energy savings potential of our concept.

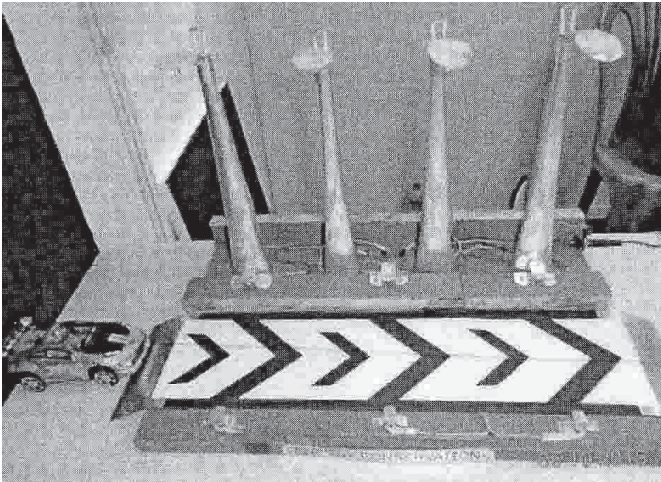

Fig. 3: *The exhibit*

APPLICATIONS

This concept can be used for street lights, highway lights, garden and park lights, office corridor lights etc.

WONDER WHEEL CHAIR

STUDENTS

Sailesh Ranjan Mohanty
Nirmal Kumar Mahapatra

Mother's Public School
Unit-I, Bhubaneswar,
Odisha

TEACHERS

Bivash Rath
Rosalin Patra

INTRODUCTION

People with disability face difficulty in moving. In this exhibit, a wheelchair have been designed that would help physically disabled persons in their locomotion according to their desire.

SCIENTIFIC PRINCIPLE INVOLVED

Infra Red (IR) sensors can be used in detecting white and black objects as white objects reflect more IR rays than the black. This concept is used in the project to detect the movement of the eyes (as all paralysed persons have the capability to move their eyes) and to move the wheel chair in the particular direction the disabled is looking.

MATERIAL REQUIRED

Three IR sensors and their modules, a 12 V, 7.3 Ah rechargeable battery, a sensor support holder or goggles, a wheelchair, a 12 V D.C. motor, and connecting wires.

CONSTRUCTION AND WORKING

(i) Mechanical Part

Two cranks are attached to a wheelchair besides the wheels by means of welding. The motors are attached vertically to the wheel using clamps. A chain is connected with another big crank to the small crank of the motors on both sides of the wheelchair. An iron plate is welded at the base of the wheelchair where a 12 V battery is installed. Now when the battery is connected to the motors the wheelchair would start to move. This wheelchair can support up to 100 kg.

(ii) Electrical Part

The electrical components are attached according to the circuit diagram illustrated below.

(iii) Sensor Support Holder

For making the sensor support holder, we moulded a plastic U-shaped head support and a thin goggles attached with it. This SSH (sensor support holder) would be worn by the paralysed person. Two pairs of IR LEDs are attached in front of the right eye glass of the goggles. Two 9 V batteries and an IR sensor

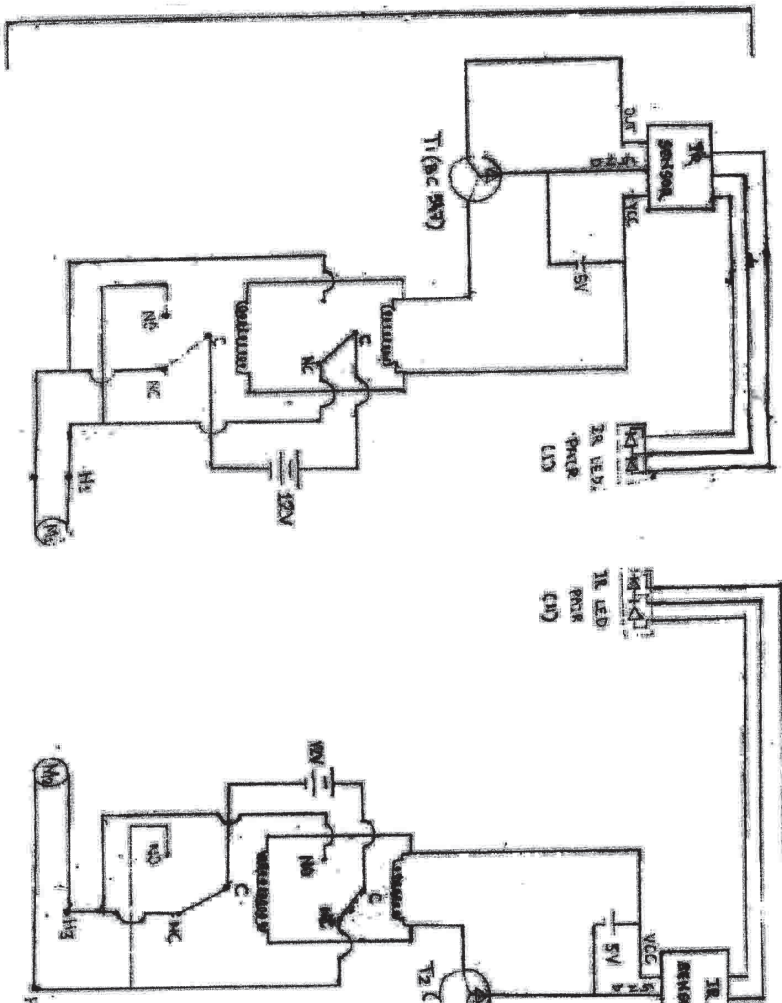

Fig. 1: Circuit Diagram

module are inserted in a printed circuit board in the head support. Six header pins are connected to the head support, out of which four headers are with motor terminals and two are with the battery terminals.

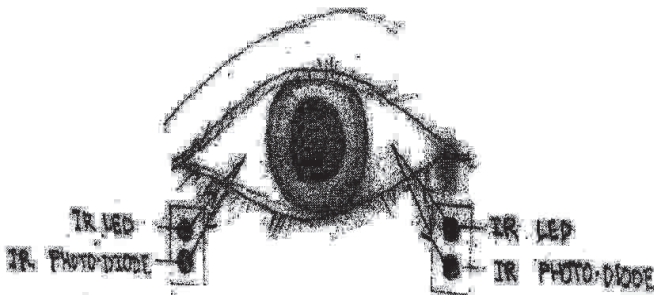

Fig. 2: Looking straight

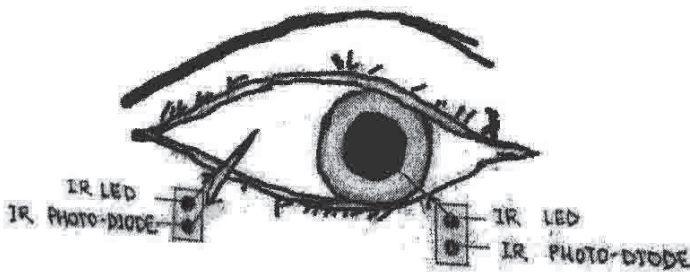

Fig. 3: Closing left

The IR LED pair which is attached side by side on the left eye glass detects the movement of the eye by differentiating the colour code of the eye. As we know that the eye of humans has main two colors which is the white part the sclera and the black part which is the iris. When we look towards left then the first IR LED pair detects the black code of the eye and the second pair detects the white code of the eye but when we look towards right the second IR LED detects the black code of the eye and the first one detects the white code. Like the way when we look straight both the pair detects the white code of the eye and when we close our eye the pair would detect nothing. According to this eye movement detection, signals are sent to the IR sensor module and then the signals are converted to electrical signals which make the motor to run and allows the wheelchair to move.

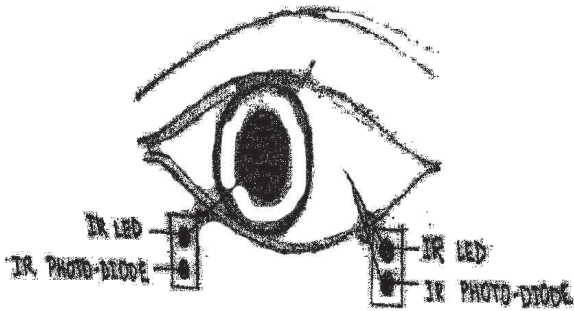

Fig. 4: Looking right

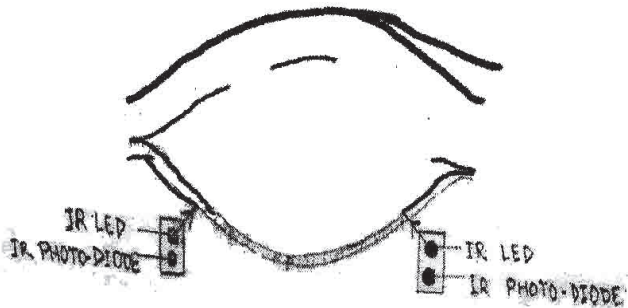

Fig. 5: Closing the eye

When the disabled after wearing the device looks straight then both the motors runs clockwise and the wheelchair goes straight. When he looks left then the right motor runs in the anti-clockwise direction but the left motor runs in the clockwise direction and the wheelchair turns left. When he looks right then the right motor runs in the clockwise direction but the left motor runs in the anti-clockwise direction and the wheelchair turns right. When he blinks his eye then both the motors runs in the anti-clockwise direction and the wheelchair goes back. To make the wheel chair stop the disabled has to close his eyes twice.

This modified wheelchair can be operated by a physically disabled person independently through his (or her) eye-movement.

REMOTE OPERATING AGRICULTURE MACHINE

STUDENT

Kunal

Arya Senior Secondary
School, G.T. Road,
Panipat, Haryana**TEACHER**R.K.Garg

INTRODUCTION

This exhibit presents a new composite machine that can be used for cultivating almost all the crops. This can be used for tilling, seeding, flattening fields, spraying pesticides etc. Presently separate machines are used for such purposes. This machine can also be manually operated.

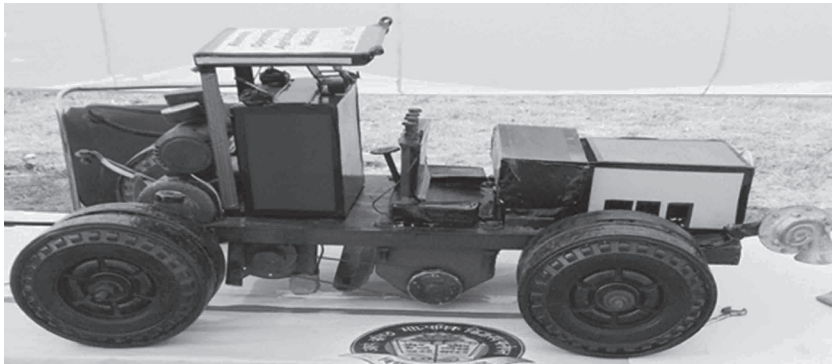

Fig. 1: Remote operating agriculture machine

SCIENTIFIC PRINCIPAL INVOLVED

This innovative machine makes use of the Principle of Bernoulli's theorem and transformation of energy.

MATERIAL REQUIRED

A half inch angle, nut-bolt and wires, an iron sheet, eight wheels, a cutter, a geared motor; an iron tank, a compressor, four ON/OFF switches, a remote control circuit, one light and a rotavator.

CONSTRUCTION

An angle iron of half inch size is used as the main frame base to construct a remote operating agriculture machine. Two iron rods are used as an axle under the main frame to derive the agriculture machine on wheels. An iron rod is connected to the gear motor. The gear motor is connected to a battery (12 V, 32 A). A seeds' chamber is built using an iron sheet. In this model a rotavator is prepared below the seeding pipes.



Fig. 2: Bottom view

Rotavator which is connected to the motor with a rubber belt, can be moved up and down. A leveller is adjusted behind the rotavator which is again made of iron sheet. Connecting to a plastic tank, an air compressor is adjusted behind the rotavator. All the connections are controlled by a remote. However, manual control can also be used.

WORKING

All agricultural activities can be performed using a remote system. First of the grass and weeds are separated from the field by an iron cutter. The roots are separated from the field by



Fig. 3: Water sprayer

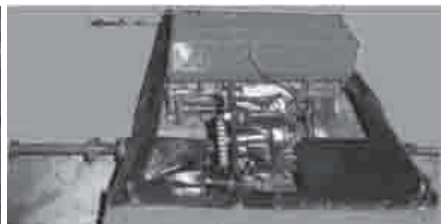

Fig. 4: Geared motor

the rotavator. By the help of seeds' chamber seeds are sowed in the given specific rows. Seeds are covered by the thin layer of soil by the leveller. Pesticides are sprayed from the tank at the time of sowing the crop with the help of the air compressor. All of these activities are performed at the same time by the this remote operating agriculture machine. A flash-light is used to work during and the horn is used to fly away the birds.

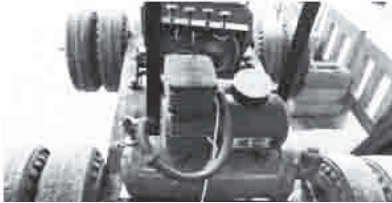

Fig. 5: Compressor



Fig. 6: Rotavator

This prototype machine costs about rupees two-thousands only. This machine can equally be used in hilly areas where the fields are often inclined.

MAT MAKING MACHINE FOR *DIVYANGS*

STUDENT

T. Tomuishang

Kakching Higher
Secondary School,
Kakching, Manipur**TEACHER**P. Sarju Singh

INTRODUCTION

Now-a-days a sizeable number of people are facing untold hardships in the struggle for existence in this scientific world. Particularly, the handicapped persons suffer a lot for lack of means to sustain themselves. They are discarded in the society since they remain out of work and unproductive as well as unaccountable.

However, in order to give them a new valued and productive life a machine called mat making machine for handicapped persons is invented.

SCIENTIFIC PRINCIPLE INVOLVED

This machine works on the principles of lever, crank, weave of wooden comb, moment of force etc. It can also produce a large quantity of mats during a short period of time.

WEAVING

Weaving is done by intersecting the longitudinal threads, the warp, i.e. "that which is thrown across" with the transverse threads, the weft i.e. "that which is woven".

KOUNA

Kouna are mostly found in the shallow lake and marshy land of Manipur valley where paddy cultivation are not suited at all. In Manipur, this plant is well adapted for making mats, cushions, domestic fancy items etc. In Manipur mat making has now become an indispensable item of furnishing the household and attract a huge foreign market.

CONSTRUCTION

This improvised mat making machine consists of a rectangular wooden frame with pillars. And a wooden axle is attached with two fixed small cranks and mounted on two pillars fixed on both sides of the rectangular frame. A small crank is connected with hard rod to a large crank attached with a hand lever and fixed at one pillar after wooden frame. The two sets of warps are also attached to two pulleys to keep it suspended from its wooden axle with the help of weight (wooden rod).

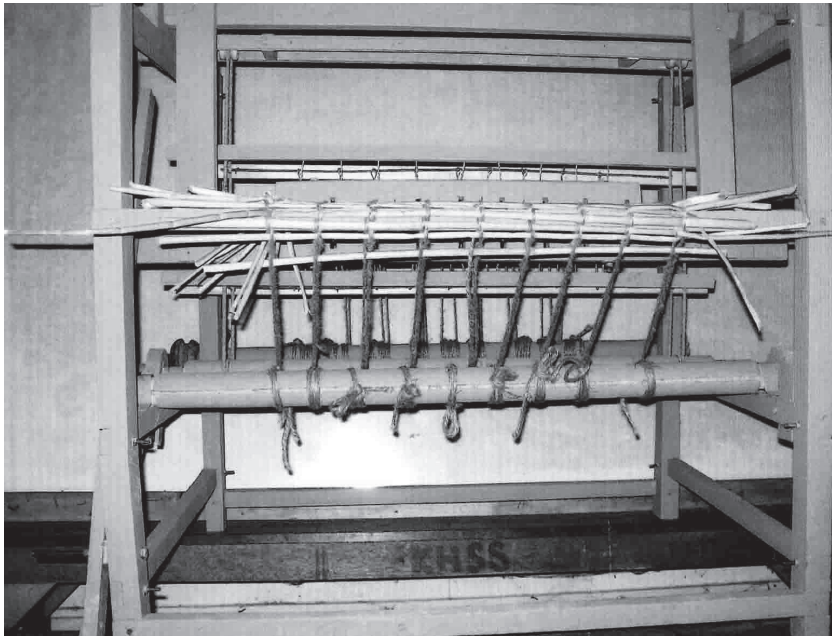

Fig. 1: Mat making machine for divyangs

SHEDDING

Shedding is the raising of part of the warp yarn to form a shed, through which the filling yarn, carried by the kouna can be inserted. The yarns are passed through the eye holes of the huddles, which hang vertically from the harness. The weave pattern determines the harness control which warp yarns, and the number of harnesses used depends on the complexity of the weave.

BATTENING

Between the huddles and the take-up roll, the warp thread pass through another frame called the reed. The portion of fabric that has already form. But not yet roll up on the take-up roll is called fell. After the kouna moves across the loom, the weaver use the reed to press each filling yarn against the fell.

WORKING

In this machine, a few twisted thread strings are fastened round it. Front roller and the thread strings come horizontal through the ring R_1 and R_2 again coming through the near frame on. Finally they reach the roller and gets fastened round it. The handle can be moved up and down and as a result these thread strings (a group up and a group down). The wooden comb can tighten the kouna by moderate strikes.

The machine can also be operated by a person having physical disabilities and even by a blind person. This innovative machine is better than the traditional machines in the sense that the later can mat in a particular pattern, whereas this compact and portable machine can be used to mat in different patterns.

SMOKE PURIFIER

STUDENTS

Manish Saini
Manik

Arya Senior
Secondary School,
Panipat, Haryana

TEACHER

R.K. Garg

INTRODUCTION

We know that air pollution is increasing day by day. Gases like carbon dioxide, carbon monoxide, nitrogen dioxide, sulphur dioxide and hydrocarbons etc. are very harmful for our environment and ecological system. Vehicles are increasing day by day, due to which the air pollution is increasing. This project called 'Smoke Purifier' is an attempt to solve the problem of high pollution in metro cities due to automobiles in heavy traffic areas.

SCIENTIFIC PRINCIPLE INVOLVED

- Cataphoresis involved in the separation of colloidal particles from aerosol of smoke.
- Sedimentation involved in the settle down of the heavy dust particle from smoke.
- Neutralisation of harmful gases by the reaction with alkali in the treatment chamber.

MATERIAL REQUIRED

Two litre capacity plastic bottles, two exhaust fans, alkali solution, a sprayer pump, a T-shape water pipe joint, an electric switch, three rechargeable batteries each of 4 V, stand, metal plates etc.

WORKING

In this project smoke is collected in the cataphoresis chamber, there the aluminium plates which creates charge on them attract the acidic/basic dust or harmful particles like carbon cations. In the sedimentation chamber the remaining dust particles are

separated by the exhaust fan which pushes the gases on a filter. Thus the heavy solid harmful particles settle down. Then the exhaust fan sucks the remaining harmful gases like NO_2 , CO_2 , SO_2 , CO etc. in the alkali treatment Chamber where the alkali reacts with harmful gases and make them neutral. There is a sprayer which sprays the NaOH on the nets of synthetic fibres after every two minutes. Finally, the fresh air with very low pollutants comes out and spreads out in the environment.

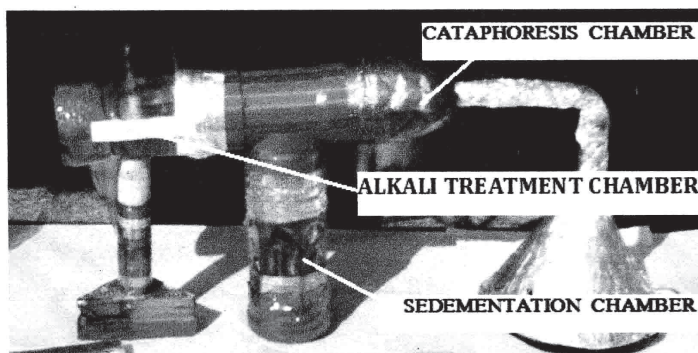
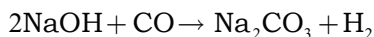
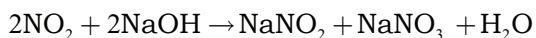
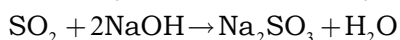
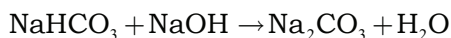
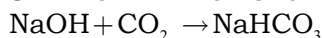

Fig. 1: Smoke Purifier

CHEMICAL REACTIONS INVOLVED



REMOVAL OF SEDIMENT PARTICLES/CHEMICALS

The nets of synthetic fibers can be taken out and then washed in alkali solution to remove solid sediments and harmful chemicals.

धुँए को वायुमण्डल में जाने से नियंत्रित करने हेतु विशेष चूल्हा

विद्यार्थी

सोनू राजपुरोहित

अध्यापक

संजय कुमार कपूर

राजकीय उच्चतर

माध्यमिक विद्यालय,

रासीसर, नोखा,

बीकानेर, राजस्थान

प्रस्तावना

गांवों में ज्यादातर लोग ईंधन के रूप में गोबर से बनी थैपड़ी का उपयोग करते हैं। लेकिन समस्या यह है कि थैपड़ी धुंआ अधिक देती है जिससे महिलाओं को दमा नामक बीमारी होने की संभावना बढ़ जाती है।

थैपड़ी के जलने से निकलने वाली ग्रीन हाऊस गैसों वायुमण्डल को प्रदूषित करती हैं जिसके कारण ग्लोबल वार्मिंग की समस्या भी बढ़ जाती है।

खाना बनाने के साथ-साथ पानी भी गर्म हो सके, इसलिए एक ऐसे चूल्हे की आवश्यकता महसूस होती है जो कि ग्रीन हाऊस गैस (धुँए) को चूल्हे से हटाकर वायुमण्डल में जाने से रोके तथा ईंधन की बचत हो सके।

सिद्धांत

1. यांत्रिक ऊर्जा को ऊष्मा ऊर्जा में बदलना।
2. धुँए का उपयोग करके रासायनिक पदार्थ बनाना।
3. धुआं आग बुझाने का कार्य करता है इसलिए चूल्हे से हटाना।

प्रयुक्त सामग्री

पुराने लोहे की चादर; पाईप; रोटरी; नपना जार; प्लास्टिक का पात्र; स्प्रिंग बैलेंस; चूना आदि।

कार्यप्रणाली

अनुपयोगी चादर लेकर एक डबल लेयर विशेष चूल्हा बनाया। चूल्हे के साइड से धुंआ बाहर निकालने के लिए चिमनी लगाकर पाईप की सहायता से एक प्लास्टिक के पात्र से जोड़ा तथा एक रोटर को जोड़कर विशेष चूल्हा बनाया।

विशेष चूल्हे के डबल लेयर (आयताकार पात्र) में ठण्डा पानी भरते हैं। थैपड़ी को जलाकर भोजन बनाते हैं। यहां भोजन बनने के साथ-साथ आयताकार पात्र में रखा पानी भी गर्म हो जाता है। इस प्रकार ईंधन की बचत हो जाती है।

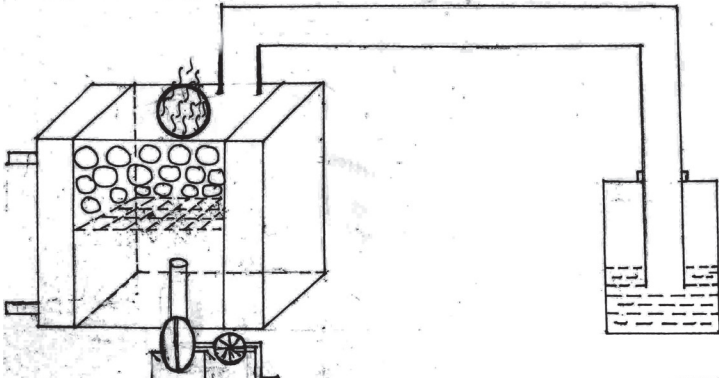

चित्र 1: विशेष चूल्हे का रेखा चित्र

थैपड़ी के जलने से बने धुंआ को चूल्हे से हटाने के लिए एक रोटर का उपयोग करते हैं, जिससे तेज गति से हवा आती है तथा धुंआ प्लास्टिक की पाईप की सहायता से एक प्लास्टिक के पात्र में स्थानांतरित कर देते हैं, जिसमें पहले से ही कार्बन डाई ऑक्साइड अवशोषक चूने का पानी/सोडियम हाईड्रॉक्साइड/सोडा लाईम रखा हुआ होता है जो कार्बन डाई ऑक्साइड का अवशोषण करके उसको कार्बोनेट में बदल देता है। इस प्रकार धुंआ चूल्हे से हट जाता है तथा महिलाओं को दमा नामक बीमारी से मुक्ति मिल जाती है साथ ही धुंआ वायुमण्डल में जाने से नियंत्रित हो जाता है जिससे वायु प्रदूषण व ग्लोबल वार्मिंग की समस्या पर नियंत्रण हो जाता है।

प्रयोग

एक पात्र में 100 g कैल्शियम ऑक्साइड लेकर इसमें 500 mL पानी लेकर 30 मिनट तक कार्बन डाई ऑक्साइड गैस प्रवाहित करने से 146 g कैल्शियम कार्बोनेट बनता है।

एक अन्य पात्र में 4 g सोडियम हाईड्रॉक्साइड लेकर 1000 mL पानी लेकर 30 मिनट तक कार्बन डाई ऑक्साइड गैस प्रवाहित करने से 5.630 g सोडियम कार्बोनेट बनता है।

एक अन्य पात्र में 100 g सोडलाईम लेकर 500 mL पानी लेकर 3 मिनट तक कार्बन डाई ऑक्साइड गैस प्रवाहित करने पर 122.2 g कार्बोनेट बनता है।

उपयोग

1. गर्म खाने के साथ-साथ गर्म पानी भी मिल जाता है, इस प्रकार ईंधन की बचत होती है।
2. धुँआ आग बुझाने का कार्य करता है, इसलिए रोटार से धुँए को चूल्हे से हटाने के कारण आग बुझती नहीं है।
3. कैल्शियम कार्बोनेट का उपयोग चॉक बनाने में प्राथमिक अभिकर्मक के रूप में किया जा सकता है।
4. कैल्शियम कार्बोनेट का उपयोग हड्डियों के इलाज हेतु दवाई बनाने में प्राथमिक अभिकर्मक के रूप में किया जा सकता है।
5. वायु प्रदूषण व ग्लोबल वार्मिंग से बचा जा सकता है।

सारांश

यह प्रदर्श रासायनिक परिवर्तन के सिद्धांत पर आधारित है। इस प्रदर्श में CO_2 अवशोषक CO_2 का अवशोषण करके एक रासायनिक पदार्थ बनाता है जिसके कई उपयोग हैं—जैसे कि चॉक और दवाईयाँ बनाने में, आदि। इस प्रकार CO_2 (ग्रीन हाऊस गैस) को वायुमण्डल में जाने से नियंत्रित किया जा सकता है तथा ईंधन की बचत भी हो सकती है।



विद्यया ऽ मृतमश्नुते



एन सी ई आर टी
NCERT

राष्ट्रीय शैक्षिक अनुसंधान और प्रशिक्षण परिषद्
NATIONAL COUNCIL OF EDUCATIONAL RESEARCH AND TRAINING