

41<sup>st</sup> Jawaharlal Nehru National  
Science, Mathematics and Environment  
Exhibition for Children  
**2014**

# Structure and Working of Exhibits



**11-17 November**  
**Chandigarh**



# Structure and Working of Exhibits

**41<sup>st</sup> Jawaharlal Nehru National Science,  
Mathematics and Environment Exhibition  
for Children**

**11-17 November 2014  
Chandigarh**



विद्यया ऽ मृतमश्नुते



एन सी ई आर टी  
NCERT

**राष्ट्रीय शैक्षिक अनुसंधान और प्रशिक्षण परिषद्  
NATIONAL COUNCIL OF EDUCATIONAL RESEARCH AND TRAINING**

November 2014  
Kartika 1934

**PD 5T MJ**

© **National Council of  
Educational Research and  
Training, 2014**

Published at the Publication  
Division by the Secretary,  
National Council of Educational  
Research and Training, Sri  
Aurobindo Marg, New Delhi  
110 016 and printed at .....

.....  
.....  
.....

**ALL RIGHTS RESERVED**

- ❑ No part of this publication may be reproduced, stored in a retrieval system or transmitted, in any form or by any means, electronic, mechanical, photocopying, recording or otherwise without the prior permission of the publisher.
- ❑ This book is sold subject to the condition that it shall not, by way of trade, be lent, re-sold, hired out or otherwise disposed of without the publisher's consent, in any form of binding or cover other than that in which it is published.
- ❑ The correct price of this publication is the price printed on this page. Any revised price indicated by a rubber stamp or by a sticker or by any other means is incorrect and should be unacceptable.

**OFFICES OF THE PUBLICATION**

**DIVISION, NCERT**

NCERT Campus  
Sri Aurobindo Marg  
**New Delhi 110 016** Phone : 011-26562708

108, 100 Feet Road  
Hosdakere Halli Extension  
Banashankari III Stage  
**Bangaluru 560 085** Phone : 080-26725740

Navjivan Trust Building  
P.O. Navjivan  
**Ahmedabad 380 014** Phone : 079-27541446

CWC Campus  
Opp. Dhankal Bus Stop  
Panihati  
**Kolkata 700 114** Phone : 033-25530454

CWC Complex  
Maligaon  
**Guwahati 781 021** Phone : 0361-2674869

**Publication Team**

Head, Publication : *N. K. Gupta*  
Division

Chief Production : *Kalyan Banerjee*  
Officer

Chief Editor : *Shveta Uppal*

Chief Business : *Gautam Ganguly*  
Manager

Editorial Assistant : *Mathew John*

**Cover**

*Girish Goyal*

## PREFACE

The learning of Science and Mathematics are instrumental in developing well-defined abilities and skills such as spirit of enquiry, creativity, objectivity, logical thinking and aesthetic sensibilities among children. Children learn through interactions with the environment around, nature, things and people. They actively engage with the world around them in exploring, responding, inventing, working things out and interpreting. Jawaharlal Nehru National Science, Mathematics and Environment Exhibition (JNNSMEE) for Children offers an opportunity to children to express and exchange their creative ideas with joy of scientific investigation. It helps them to learn the methods of science and mathematics, provide them with opportunity to develop their problem-solving skills and creative abilities.

The National Council of Educational Research and Training (NCERT) organises the Jawaharlal Nehru National Science, Mathematics and Environment Exhibition (JNNSMEE) for Children as an annual event in collaboration with a State or Union Territory. The JNNSMEE is the culminating activity of a series of exhibitions organised at school, zonal, district, regional and state levels. A large number of students and teachers participate in such events.

The present publication, 'Structure and Working of Exhibits' includes write-ups of a few exhibits selected for display in the 41<sup>st</sup> JNNSMEE-2014 which is being organised in Chandigarh during 11-17 November, 2014. Other materials like 'List of Exhibits' which contains the titles and synopsis of exhibits selected for participation in the JNNSMEE-2014 along with information brochures stating objectives and other details of the exhibition have also been published. It

is expected that these publications will motivate and help children to participate in future Exhibitions.

The write-ups included in the present publication were selected out of the entries received from all the states/UTs and other organisations. These were reviewed and edited by an expert committee in the Department of Education in Science and Mathematics, NCERT.

Completing the task related with the editing and publishing of this booklet has been possible because of the continuous efforts of my colleague Shri R.R. Koireng. I also thank Dr A.K. Shrivastava for his support. Further, I thank Ms. Meenakshi, Puneet Bholra and Ashutosh Kumar for helping the department in bringing out this booklet. We also thank the Publication Division, NCERT for their cooperation.

A.K. Wazalwar

*Professor and Head*

Department of Education in  
Science and Mathematics

New Delhi

1 November 2014

National Council of Educational  
Research and Training

# CONTENTS

PREFACE	<i>iii</i>
1 3D Stereoscopic Viewer	1
2 Nano in Human Health	6
3 Step Climbing Trolley	10
4 Reflected Altitude Triangle	13
5 New Paddy Thresher	16
6 Ningthiba Taijep	18
7 Phases of Moon	21
8 Solar Agriculture Equipments	24
9 R.C.M.A. Robo	30
10 Chakrabyuha	35
11 Multipurpose Qualities of Soapnut	43
12 Environmentally Safe Wood Stove	49
13 Pollution Free Cool House	51
14 Drowned Article Searcher	54
15 Intelligent Ambulance and Multipurpose Traffic Signal	56
16 Steps of Mathematical Modelling	62
17 Multipurpose Geothermal Plant	69
18 Air Thermometer	72
19 बहुस्तरीय भट्टी	76
20 रोबो आर्म	80



Nirmalya Chakraborty, College of Art, New Delhi

## 3D STEREOSCOPIC VIEWER

---

**STUDENT**

Vijenbhai Dineshbhai Patel

Government Higher  
Secondary School,  
Rakholi, Dadra and  
Nagar Haveli**TEACHER**Mandakini I. Chauhan

---

**INTRODUCTION**

Stereoscopes, also known as stereopticons or stereo viewers, were one of America's most popular forms of entertainment in the late 1800s and early 1900s. The first patented stereoscope was invented by Charles Wheatstone in 1838. Wheatstone had experimented with simple stereoscopic drawings in 1832, several years before photography was invented. Later, the two principles were combined to form the stereoscope.

However Wheatstone's stereoscope was not as popular as a later version, made by Oliver Wendell Holmes. Holmes stereo viewer was the most common type of stereoscope during 1881 to 1939.

**How it Works**

A stereoscope is composed of two pictures mounted next to each other, and a set of lenses to view the pictures through. Each picture is taken from a slightly different viewpoint that corresponds closely to the spacing of the eyes. The left picture represents what the left eye would see, and likewise for the right picture. When observing the pictures through a special viewer, the pair of two-dimensional pictures merge together into a single three-dimensional photography.

We can see a 3D picture through a stereoscope for the same reason a building appears three-dimensional. The right and left eyes see a slightly different version of the same scene, and taken together, we get an illusion of depth. This phenomenon had been known for quite some time, ever since the ancient Greek mathematician Euclid discovered the principles of binocular vision.

## **MATERIAL REQUIRED**

For making this exhibit (Fig. 1) we have used: two small pocket mirrors of same size; 2 pieces of thick plywood cut slightly smaller than mirrors; thick plywood for base; 4 rectangular wooden blocks; 2 strips of thinner wood or masonite about 12.5 cm × 3 cm; 4 metal L- shape brackets and screws to fit; 10 wood screw of 1 inch (2.5 cm) long and epoxy glue.

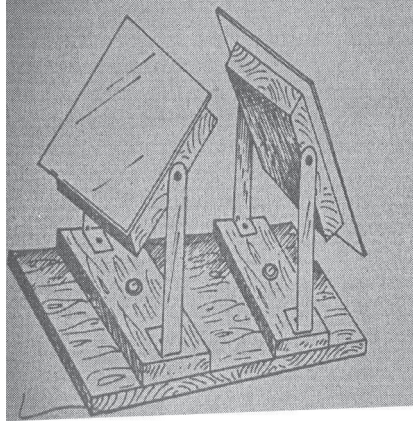

**Fig. 1: 3D Stereoscopic Viewer**

## **DEPTH PERCEPTION**

The best drawing or photograph does not reproduce the context as we see. The essential difference lies in depth perception. We can thank the combined efforts of both eyes for that. The brain receives two slightly different images from each eye and fuses them together to make one image. The result allows us to perceive our surroundings in perspective.

Using the same principle this stereoscopic viewer or stereoscope simulates depth perception using homemade drawings.

## **MAKING THE STEREOSCOPE**

To construct the mirror units of the stereoscope, centre and glue the plywood pieces to the back of the mirrors so that no more than a quarter inch of the mirror protrudes along each edge. Allow several hours for the glue to dry. Measure the longer sides of each plywood piece, and make a pencil mark along the edge at the midpoint. Screw the long end of each L-shape bracket to the pencil marks with the shorter ends to the wooden blocks. Make sure the brackets line up so that the mirrors are level.

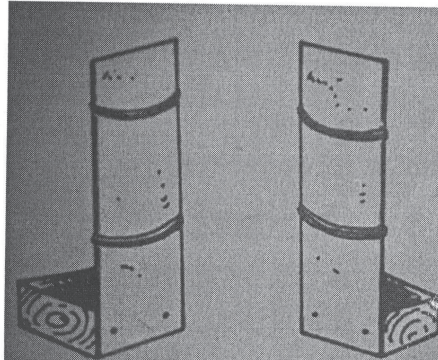

**Fig. 2: Mounting Boards**

Measure the long sides of the plywood base, and divide the surface into half with a line. On each side of that line and parallel to it, draw another line quarter inch away. Place the mirrors upside down, top edge against these outside lines, so that half an inch of space separates them. Mark the plywood base—both on the surface and along the edge—with x's where the brackets connect to the side of the mirrors.

Flip the mirror unit over, placing the wooden blocks between the x's and make sure the mirrors are no more than  $\frac{1}{2}$  inch apart when tilted perpendicular to their brackets.

Measure the length and width of each wood block, and mark the exact centre. Attach the blocks to the base with an inch wood screws through the marks making sure each block pivots freely from side to side. Both mirrors should also pivot between their brackets. This is important for making viewing adjustments later on.

To make the mounting boards for the stereoscopic picture, screw long strips of thin plywood or masonite against the side of the remaining wooden blocks. Stand the boards upright on their blocks, and loop two rubber bands around. Place the mounting boards at the opposite sides of the finished viewer. Each board should face a mirror from a distance of about 8 inches.

When the two drawings shown in Figure 3 are viewed through a stereoscope, they combine to form a single three-dimensional image. Notice the four planes of perspective in each drawing—fence, house, barn and clouds; and how the horse, barn and clouds have been moved to the right in Drawing-B.

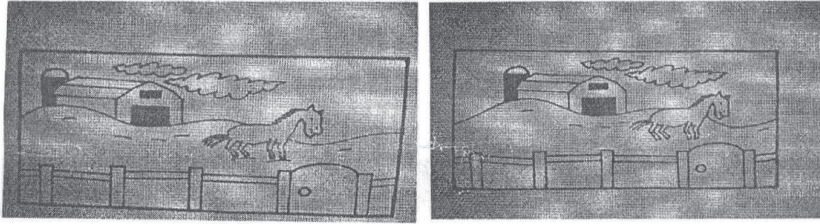

**Drawing-A**

**Drawing-B**

**Fig. 3: Farmscape**

These drawings make a stereoscopic pair. One can make choice of one's own object pairs. Objects such as low bushes, cows, distant trees, airplanes can be replaced by other objects. But the foreground, middle distance, background and distant background in the first drawing must exist.

Look again at the farmscape. Drawing-B was traced from Drawing-A in stages. The fence was traced exactly in position. Then tracing paper was moved  $\frac{1}{8}$  inch to the left, and the horse was traced. The barn was traces after moving the tracing paper another  $\frac{1}{8}$  inch to the left, and finally a fourth plane was added by moving the paper another  $\frac{1}{8}$  inch to the left and tracing the clouds.

Colour pencils can also be used for the drawings. Colour enhances perspective and often suggests its own perspective. Blue, for instance, appears to be behind red or yellow on a flat surface.

### **STEREOSCOPIC PHOTOS**

You can also create stereoscopic pair with two photos. For a close-up, still life, or portrait, take the first photo with the subject about 2 feet from the camera. Move the camera 3 feet to the right and take a second photo. The first photograph represents the left eye's view and second, the right eye's view.

For more distant subjects, estimate the distance between the camera and the nearest object, say a house and move the camera to the right about  $\frac{1}{8}$ th of that distance for the second photo. If the house sits 100 feet away, move the camera  $12\frac{1}{2}$  feet to the right for the next photo.

### **STEREOSCOPIC VISION TEST**

Attach a drawings to the mounting boards to test the viewer. Place on original drawing on the right board, securing it with rubber bands. Place the traced drawing on the left board, secured it the

same way. Position both drawings at the middle of the mounting board and brightly illuminate them with desk lamps.

Tilt the viewer's mirror away from each other at a 45 degree angle. Sit in front of the viewer and keep your head down over it, with one eye over each mirror, until you see two separate drawings completely filled the mirrors. Now carefully adjust the mirrors (remember, the mirrors pivot against their brackets as well as against the base) until the drawing overlap and the space between the mirrors disappears. The effect is miraculous.

You could draw the first half of many stereoscopic pairs and invite viewers to create the second half by tracing the first. Make sure that you have enough tracing paper and colour pencils to go around.

## NANO IN HUMAN HEALTH

---

### STUDENTS

Nafisa Mondal  
Firdous Biswas

Rashmoni Bailka Vidyalaya,  
Kolkata, West Bengal

### TEACHERS

Rinku Das Gupta  
Sutapa Pramanik

---

### INTRODUCTION AND SCIENTIFIC PRINCIPLE INVOLVED

This exhibit attempts to demonstrate the application of nano science in day-to-day life particularly in the field of medical science.

It can be inferred from scientific studies, experiments and observations that certain substances behave in unusual ways when they are broken down to nano size, i.e.  $10^{-9}$ m. In the field of medical sciences, this unusual behaviour has been utilised for the benefit of human beings. The nano particles help us to change pharmacokinetic properties of medicinal drugs without changing the active compound. The large surface area to volume ratio of the nano particles is one of the reasons responsible for this intrinsic characteristic. The targeted release of a drug in a controlled manner by using the surface functionalisation technique is possible with the help of nano particles.

### MATERIAL REQUIRED

In this exhibit we have used the following items to demonstrate the usefulness of gold nano particles in the field of oncology:

LED lights (different colours); one LED strip; 16 screws; 2 bakelite boards; Electrical wires; 2 two-pin switch; One three-pin switch; 2 transformers; 6 diodes; 2 capacitors and 2 resistors.

### CONSTRUCTION AND WORKING

Figure1 shows the construction of this model where the yellow LEDs represent the nano gold particles, the white LEDs represent the laser beam, the red LEDs represent the healthy body cells

and the green LED denote the burnt cancerous cells after treatment. The LED strip represents a thermometer. The injection of gold nano particles with the carrier molecules and its flow through our blood stream is represented by the blinking of the yellow LED lights and will reach the cancerous tumor represented by a hole which is surrounded by healthy cells represented by red LEDs.

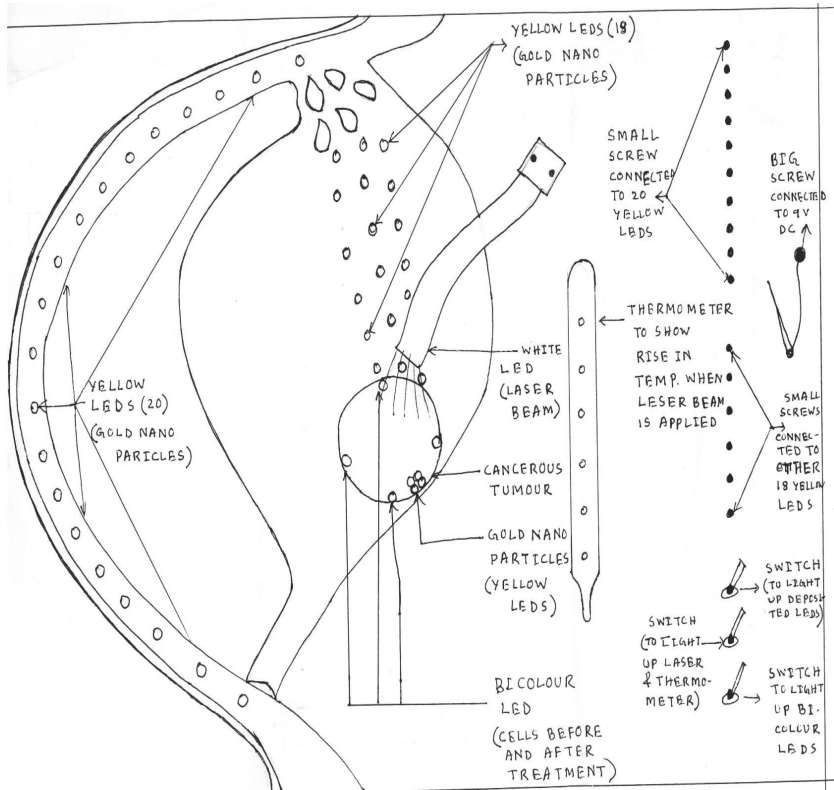

**Fig. 1: Labelled Diagram of the Model**

When laser beam, represented by white LED, is applied, the nano gold particles appear to be heated up. The rise in temperature is shown by the blinking of the LED strip. The gold nano particles burn and destroy the cancerous cells and is represented by green LEDs. The green LEDs then change to red LEDs which signify that the burnt cancerous cells have been replaced by healthy cells.

## APPLICATIONS

This technique can be used for precise detection of cancerous cells and destruction of the same leaving behind the normal healthy cells. This can solve the problems faced by the usual practice and side effects of chemotherapy wherein both the cancerous as well as healthy cells are destroyed.

The properties of nano particles are also useful to cure different other ailments like alzheimer, diabetes, etc. Use of buckyballs (Fullerenes – C60) in medical science has helped doctors to cure a lot of dreadful diseases. The anti-bacterial of nano silver particle is used for treatment of cuts and wounds, bone cementing, HIV, etc.

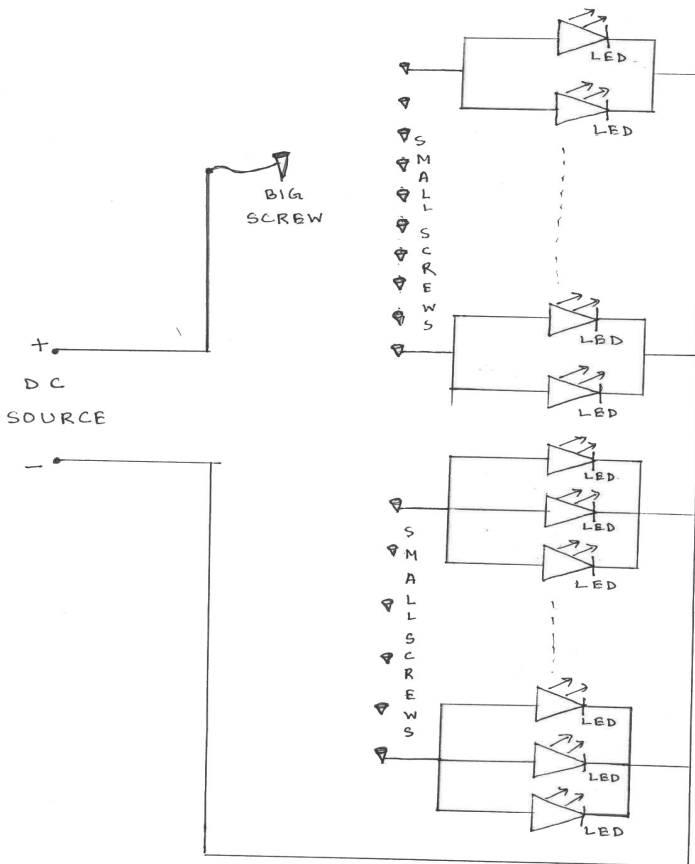

**Fig. 2: Circuit Diagram**

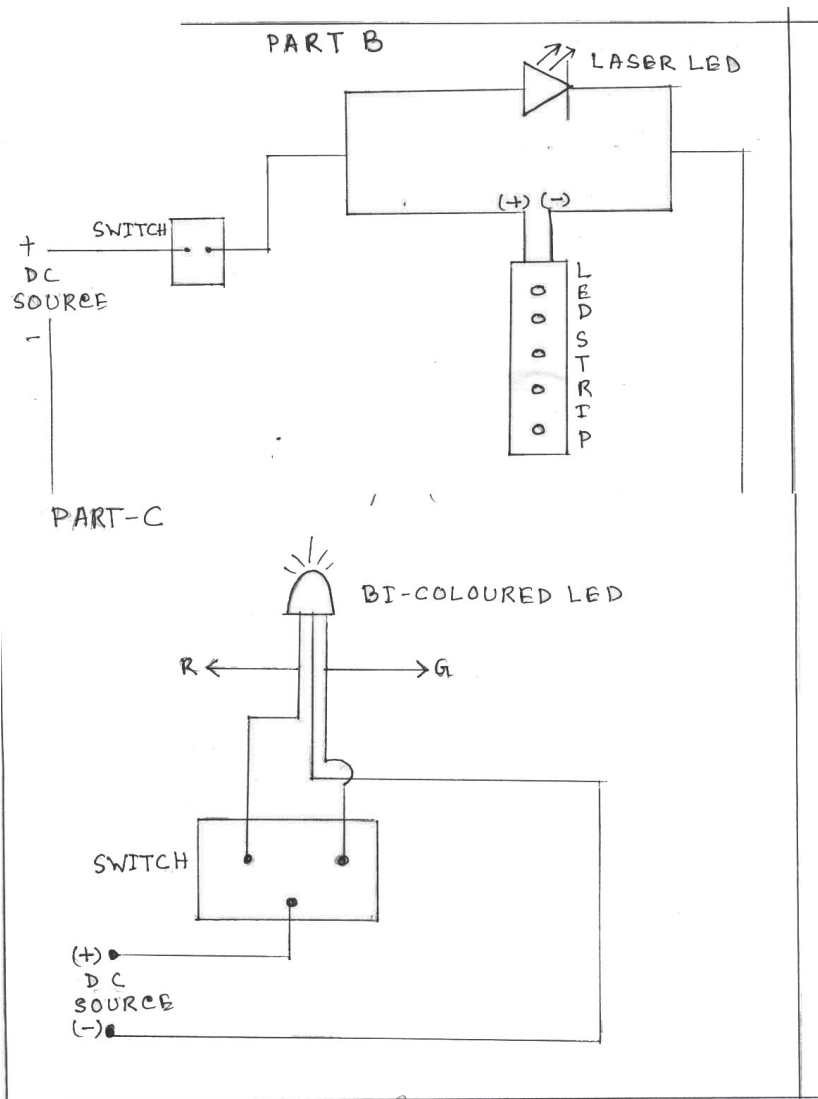

**Fig. 3: Circuit Diagram**

## STEP CLIMBING TROLLEY

---

---

**STUDENT**

Abhijit Vargese

Jawahar Navodaya Vidyalaya  
Palakkad, Kerala**TEACHER**

Saji P.C.

**INTRODUCTION**

During journey most of us use trolley bags nowadays which can pull heavy luggage easily. But this trolley can be used only in plane surfaces. While climbing stairs and over bridges in railway stations it is very difficult to carry the luggage as it cannot be pulled along the stairs. We observed that many people, especially aged and ladies find difficulty in carrying trolley through these steps. This made us to think of a solution for this problem.

**SCIENTIFIC PRINCIPLE INVOLVED**

- (i) Rolling friction reduces effort.
- (ii) Less effort is required in pulling than pushing.
- (iii) Curved arm can easily moved through irregular surfaces.

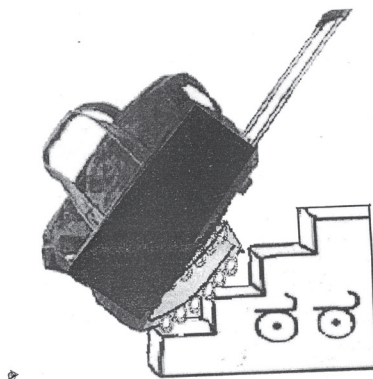

**Fig. 1: Step Climbing Trolley**

## CONSTRUCTION AND WORKING

We observed that in war field, tanks can move through any surfaces due to the arrangement of its wheels.

Also we watched in TV that the arms of skater are curved which help in moving through irregular surfaces. We combined both the ideas together. Then we made curved arm on which a number of wheels are attached. So we used a number of ball bearings and fixed them together on a curved arm. With the help of this structure we can pull the trolley through the steps. This is a model of step climbing trolley.

The arrangement should be in such a way that it should protrude out in a particular angle while pulling through the steps. In this way we made the arrangement with a handle to pull.

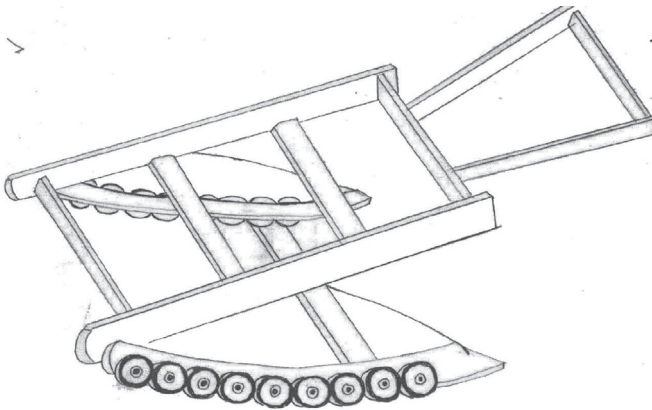

**Fig. 2. Wheels on Curved Arm**



**Fig. 3. Trolley through the steps**

### **SCOPE FOR IMPROVEMENT**

There is further scope for improvement for this model. Instead of wood we can use light materials like aluminium rod and the whole structure can be concealed inside the bag. Sensors can be used to detect the steps. On detection of the steps, the curved arm with wheels will come out automatically and the person can pull the trolley easily through the steps. When the steps are over, and the trolley reaches the plane surface, this curved structure will go inside and the person can pull the trolley as normal trolley.

## REFLECTED ALTITUDE TRIANGLE

---

### STUDENTS

P. Meghana  
D. Nikhitha  
D. Vamshi

Paramita High School,  
Karimnagar, Andhra Pradesh

### TEACHER

Lalit Mohan Sahu

---

### INTRODUCTION

The aim behind the construction of this exhibit is to prove the minimum property of the altitude triangle which states that the perimeter of the altitude triangle is less than the perimeter of any other inscribed triangle in an acute angled triangle.

### SCIENTIFIC PRINCIPLE INVOLVED

The scientific principle involved to prove the minimum property of altitude triangle is the reflection property of altitude triangle which states that "At each vertex, the two sides of the altitude triangle make equal angles with sides of original triangle and this angle is equal to the angle at the opposite vertex of the original triangle".

### MATERIAL REQUIRED

Wooden sticks; nails; woollen threads; chart paper; card sheet, etc.

### CONSTRUCTION AND WORKING

In order to construct the model 'reflected altitude triangle' first of all an acute angled triangle (ABC) is taken and its altitude (AP, BQ, CR) are drawn with the help of the foot points of altitude and triangle called altitude triangle (PQR) is drawn. Again other than altitude triangle (PQR), another inscribed triangle (LMN) is drawn. Now the original triangle contains two triangles, altitude triangle (PQR) and an inscribed triangle (LMN).

Now reflect the whole figure first in the side AC of ABC, then reflect the resulting triangle in its side AB, then in BC and then again in AC and finally in AB. In this way we obtain altogether six congruent triangles each with the altitude triangle and the other one inscribed.

In the first reflection, BC is rotated clockwise through an angle  $2C$ , then through  $2B$  clockwise. In the third reflection, it is not affected, in the fourth it rotates through  $2C$  counter clockwise, and in the fifth through  $2B$  counter clockwise. Thus the total angle through which it has turned is zero. Therefore the side BC of last triangle is parallel to the original triangle BC.

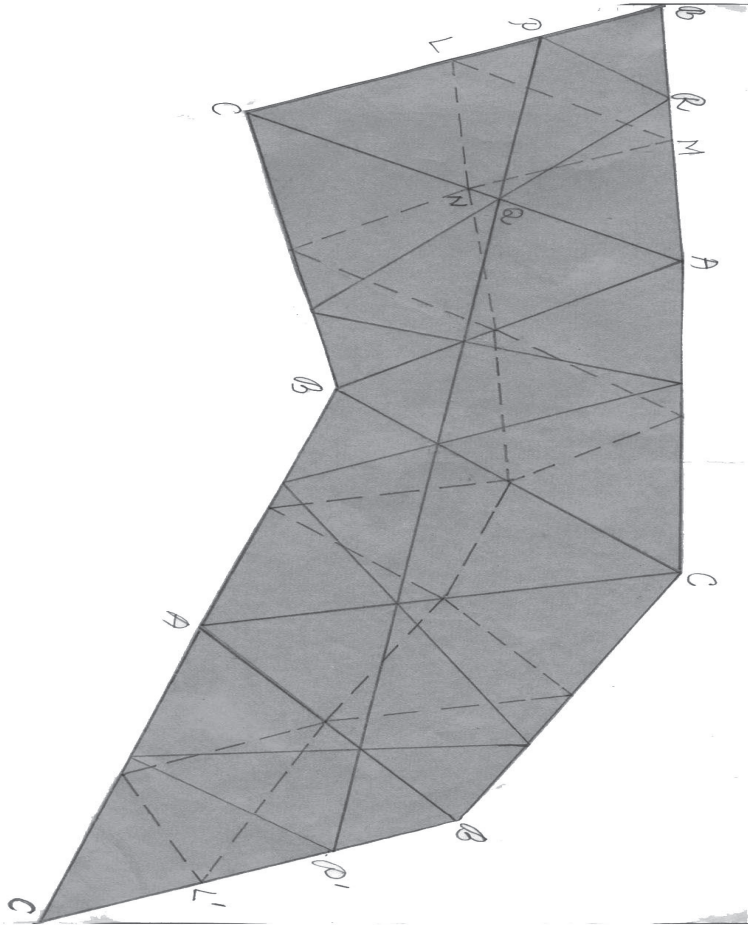

**Fig. 1: Design of the Model**

Due to reflection property of the altitude triangle, the straight line segment  $PP'$  is equal to twice the perimeter of the altitude triangle; for  $PP'$  is composed of six pieces that are in turn, equal to the first, second and third side of the triangle, each side occurring twice. Similarly the broken line from  $L$  to  $L'$  is twice the perimeter of the other inscribed triangle. This line is not shorter than the straight line segment  $PP'$ . Since  $PP'$  is not parallel to  $LL'$ , the broken line from  $L$  to  $L'$  is not shorter than  $PP'$  and therefore the perimeter of the altitude triangle is the shortest possible for any inscribed triangle as was to be proved.

Thus we have shown that the perimeter of altitude triangles is minimum as compared to any other inscribed triangle of that triangle. No other triangle with perimeter equal to that of the altitude triangle will be seen.

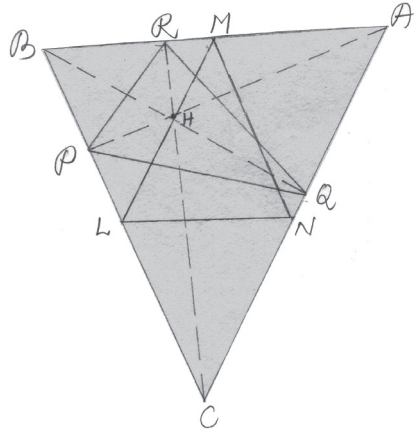

**Fig. 2: Altitude Triangle**

### APPLICATIONS

This exhibit has a wide range of applications and practical utility. These are as follows:

- (i) The model is very useful to understand and internalise the minimum property of altitude triangle practically and easily.
- (ii) The model is useful to find the minimum distance between congruent triangular places with net angle rotation of zero degree.
- (iii) This model is useful to understand the basic concepts of congruency and symmetry.
- (iv) This model is also helpful to understand the basic concepts of altitude, orthocentre, median and centroid etc.
- (v) The model is very helpful to prepare different types of pyramids and to prove Euler's rule for polyhedron.
- (vi) This model can also be used to prepare localized boats.

## NEW PADDY THRESHER

---

**STUDENT**

Akoijam Kheroda Devi

Anand Purna School,  
Thoubal District, Manipur**TEACHER**

T. Robindro Singh

---

**INTRODUCTION**

In most of the agricultural land area of Manipur, people mainly cultivate paddy. Agriculture sector contributes a major share to the total state domestic product. It provides employment to about half of the total farmers in Manipur. During harvest, farmers spend a lot of money as labour charges to thresh the paddy. In view of this, an eco-friendly machine (model) called 'New Paddy Thresher' is developed. 'New Paddy Thresher' is a manual threshing machine. It can thresh the paddy plants without cutting the straws. Such an eco-friendly machine will help the poor farmers of the country in general and farmers of Manipur in particular to improve their economy.



**Fig. 1: New Paddy Thresher**

**MATERIAL REQUIRED**

The material used in this exhibit are: U-shape beating rods; Bearing; Crank shaft; Iron chain; Wood; Bolts and nuts; Paddle; Paddy straw fixer.

### **SCIENTIFIC PRINCIPLE**

'New Paddy Thresher' is based on the principle of pulley and Lever system.

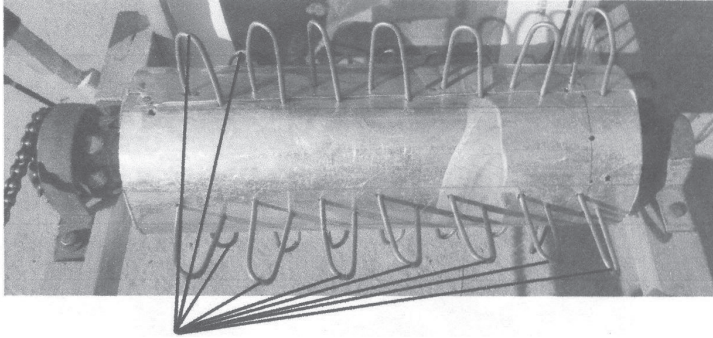

**Fig. 2: U-Shape Beating Rods**

### **CONSTRUCTION AND WORKING**

Four rows of U-shape beating rods are fixed on a cylinder. The two end of the beating cylinder are fixed by two bearing so as to rotate freely. A pulley is fixed on one end of the beating cylinder and joins the crank shaft with the iron chain. In one complete rotation of the crank, the beating cylinder rotates twice. An arm-ful of paddy straw can be beaten eight times in one complete crank rotation. Three crank rotation is enough for threshing one arm-ful of paddy.

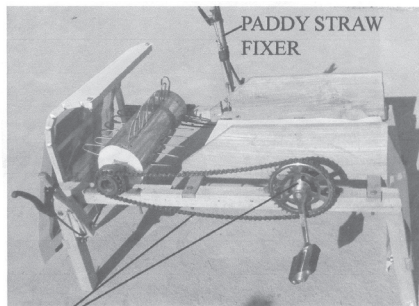

**Fig. 3: Crank Shaft with the Iron Chain**

### **ADVANTAGES**

- (i) It is low cost and portable.
- (ii) It is an eco-friendly machine.
- (iii) A farmer can save labour and money by using this thresher.

## NINGTHIBA TAIJEP

---

**STUDENT**

Sanjenbam Bony Singh

Ananda Purna School,  
Thoubal, Manipur

**TEACHER**

Sapam Swaminath

---

**INTRODUCTION**

“Taijep” is an indigenous fishing implement of Manipur which is widely used to trap fishes in the lakes, ponds, rivers, drains and even in paddy fields where fresh water is available in plenty. A traditional Taijep is a tetragonal shaped body having approximate dimensions of 8” × 10” × 24” with an entrance called “Shou”. In Manipur, most of the people engaged in agriculture are mainly accustomed to catch fish, which contributes to their income and food security.

Fishermen use different types of indigenous implements such as Net, Een, Loo, Longoop, Kao, Long, Taijep etc. for trapping different fishes. Among these, Taijep is widely used to catch fishes in any season.

Ningthiba Taijep is an innovative fishing implement which is modified from the traditional Taijep. It has a tetragonal shape having dimension of 1.5’ × 1.5’ × 2’. Four valves (Shou) are fixed on the four lateral surfaces. A cylindrical shaped body called “Pajeng” (feeding area) is also fixed at the center of it so as to be targeted by the fishes. It has four entrances. Ningthiba Taijep, an improved device for fishermen has been designed and dedicated to the fishermen community of the nation to improve the overall socio-economic conditions in rural areas and the state as a whole.

## MATERIAL REQUIRED

- (i) Bamboo
- (ii) Binding Plastic

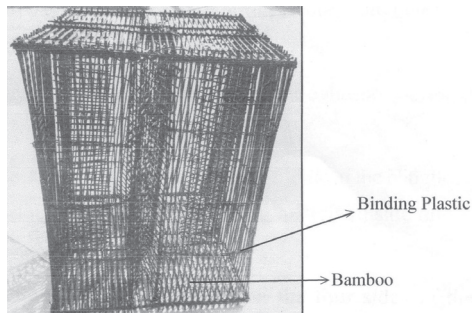

**Fig. 1: Ningthiba Taijep**

## CONSTRUCTION

- (i) In “Ningthiba Taijep”, bamboos are cut at different heights, i.e. 2 feet and 1.5 feet.
- (ii) Again cut the bamboo pieces lengthwise to make *Payas* (twig of bamboos) of around 5mm diameter.
- (iii) 138 pieces of *Payas* are collected and arranged in a rectangular form. The *Payas* are bound by using binding plastic which gives it a fixed shape.
- (iv) A cylindrical shape body is also fixed in the middle of the Ningthiba Taijep (feeding area). A feeding material is put inside this to attract fishes.
- (v) The valves (shou) on the four sides of the ‘Ningthiba Taijep’ are fixed.

## WORKING

- (i) We should immerse this implement fully in water.
- (ii) As fishes are of different kinds, their movements are also different. Some fishes like to move towards the direction of the water current, some like to move opposite to the direction of the water current and some fishes like to move in stagnant water. To catch all such types of fishes simultaneously, we put such four valves on all the four sides.

- (iii) In the middle of “Ningthiba Taijep” is a fixed cylindrical shape body (feeding area) where feeding material is placed to attract fishes.

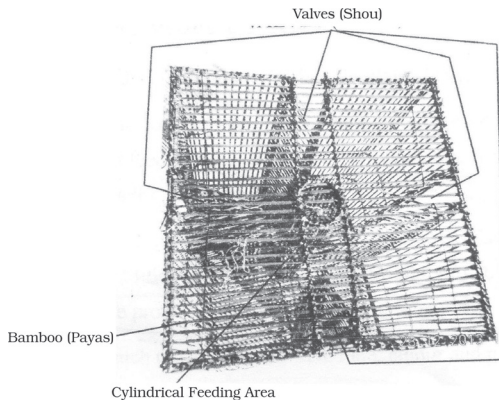

**Fig. 2. Feeding Area of Ningthiba Taijep**

### **DIFFERENCE BETWEEN INDIGENOUS FISHING IMPLEMENT (TAJEP) AND NINGTHIBA TAJEP**

- (i) A traditional Taijep is a tetragonal shaped body having approximate dimensions of 8” × 10” × 24” with one entrance called “Shou” whereas “Ningthiba Taijep” has also a tetragonal shaped body having dimension of about 1.5’ × 1.5’ × 2’ but the entrance are provided on all the four sides.
- (ii) In “Ningthiba Taijep” there is a cylindrical shaped body (feeding area) where as in traditional Taijep there is no such cylindrical shaped body.

### **ADVANTAGES OF NINGTHIBA TAJEP**

- (i) It can trap different kinds of fishes simultaneously.
- (ii) Since it has four valves (shou) around the fixed cylindrical transparent feeding area, it enables to trap more fishes than the traditional one. This can solve the problem of food security in Mainpur.
- (iii) One can save time, labour and money by using this implement.

### **DISADVANTAGES OF NINGTHIBA TAJEP**

Ningthiba Taijep has larger dimension than the indigenous ones.

## PHASES OF MOON

---

### STUDENTS

Manveer Kaur  
Japendra Singh Bhatia

P.M.L.S.D. Public School  
Sector 19- C, Chandigarh

### TEACHERS

Ishani Sharma  
Saraswati Sharma

---

### INTRODUCTION

Every night, the Moon shows a different face in the night sky. On some nights, we can see its entire face; sometimes a part of it and sometimes it is not visible. These are the phases of the Moon which changes throughout the month.

As the Moon travels in its 29 days orbit, its position changes daily. So, a different section of the Moon's face is lit up by the Sun, causing it to show different phases.



**Fig. 1: Design of the Model**

### SCIENTIFIC PRINCIPLE INVOLVED

The revolution of the Moon around the Earth makes the Moon appear as it is changing shape in the sky. Moon does not produce its own light. We see the Moon because the sunlight falling on it gets reflected towards us. We, therefore see only that part of the Moon from which the light of the Sun is reflected towards us. The Moon phases are produced by the alignment of the Moon and the Sun with respect to the Earth in the sky.

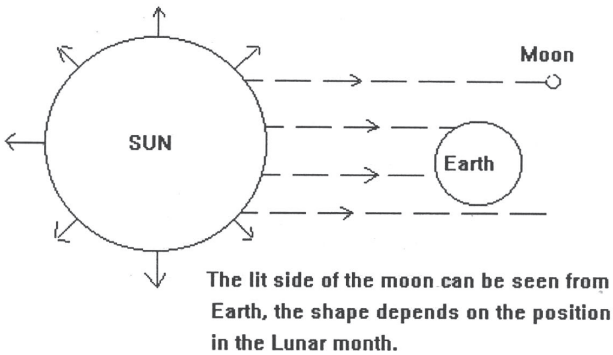

**Fig. 2: Sunlight falling on the Moon**

### MATERIAL REQUIRED

Cardboard, red and black chart papers, thermocol, fevicol, a small ball, thread, scissors and torch.

### CONSTRUCTION

- (i) One cardboard for base.
- (ii) Black chart papers and cardboard to show Earth (at night).
- (iii) Thermocol to show different phases of Moon.
- (iv) A ball to show Moon.

### WORKING

We take two black chart papers. We divide both of them horizontally in two equal parts. Now one by one we divide the upper portion of the chart paper into four equal rectangles. These four rectangles are taken at an equal distance from one another and then we cut them out. Now, we attach both the

chart papers with each other and fold them into a cylindrical shape. We cover the upper and lower portion of this cylinder by black chart papers. At the centre of the upper cover we attach a white ball whose height is equal to the square window. It represents our Moon. When light from one of the windows that represent the source of light, i.e. Sun, falls on the inner ball that represents Moon, then from each rectangular window we can see different phases of Moon.

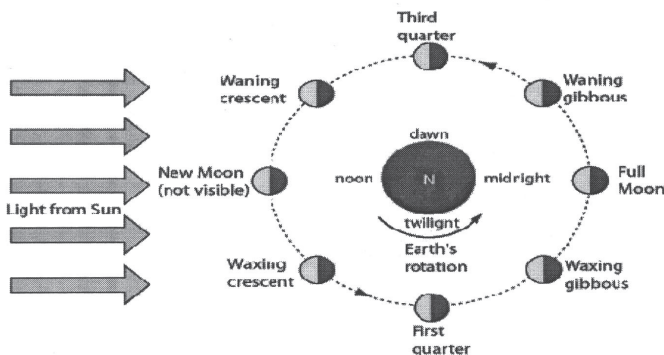

**Fig. 3: Phases of Moon**

### **ADVANTAGES**

- (i) Phases of the Moon can be explained easily with the help of this model.
- (ii) Easy to understand.

### **APPLICATION**

This model is used to represent different phases of moon. Due to revolution of Moon around Earth, we see different phases of Moon.

## SOLAR AGRICULTURE EQUIPMENTS

---

**STUDENT**

Keshav G. Patil

Sri Rukmangad High School,  
Bijapur, Karnataka**TEACHER**

Laxman H. Kulkarni

---

**INTRODUCTION**

The over exploitation of fossil fuel like petroleum has led to environment degradation and energy crisis. Petroleum is a non-renewable source of energy, so we need to conserve it. At the same time burning of petroleum releases oxides of carbon, nitrogen and sulphur that are released on burning petroleum are acidic oxides. They lead to acid rain which affects our water and soil resources. In addition to this, the green-house effect of gases like  $\text{CO}_2$  is increasing at an alarming rate. In order to avoid this, alternate source of energy like the solar energy can be used in the field of agriculture. The use of solar energy in agriculture not only reduces our dependence on the fossil fuels, but also protects our environment from pollution and is also economical. Development of solar agriculture equipments is a step towards better, economic and eco-friendly agriculture. This project is an attempt to solve the problems arising due to environment degradation and energy crisis. In the present model we have suggested a series of six agricultural equipments which work on solar energy. These equipments are: (i) Solar electric grain separator, (ii) Solar electric crop cutting machine, (iii) Solar electric tractor, (iv) Solar electric mixer, (v) Solar electric spray machine, and (vi) Solar electric fence. These equipments use solar energy thereby saving diesel and conventional electricity.

**SCIENTIFIC PRINCIPLE INVOLVED**

The Solar panels convert sunlight into electricity in accordance with the principle of 'photo electric effect' and the electric energy is converted into mechanical energy.

The electric energy is used to run Tractor, Grain separator, Crop cutting machine, Spray machine, Farm fence and Grain mixer.

### **MATERIALS REQUIRED**

Five 12V D.C. motors; gear wheels; axels; plywood wheels and a rubber wheel; solar panel; motor pulleys; Z-type plate; metal rod; book bracket; two sharp scissors; 12V battery; copper wire for fencing; amplifier; speaker; plastic cup; plastic pipes; plastic boxes and nickel blades, etc.

### **CONSTRUCTION AND WORKING**

The present exhibit (working model) consists of the following six agriculture equipments.

#### **(A) SOLAR ELECTRIC GRAIN SEPARATOR**

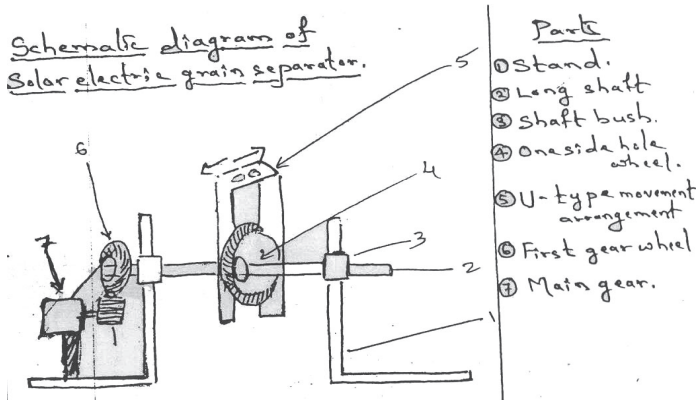

**Fig. 1: Solar Electric Grain Separator**

Two plastic plates with a guage at the centre are mounted on a rectangular wooden plane. The working mechanism consists of a 12V D.C. motor fitted to a shaft and gear system. The crank arrangement converts the rotational motion into linear motion. The motor is connected to the Solar panel. The sunlight falling on the Solar panel produces electricity and thus the motor starts working. The guage plate makes 'to' and 'fro' motion and hence the grains are separated from their mixture with fodder and other waste particles.

## (B) SOLAR ELECTRIC CROP CUTTING MACHINE

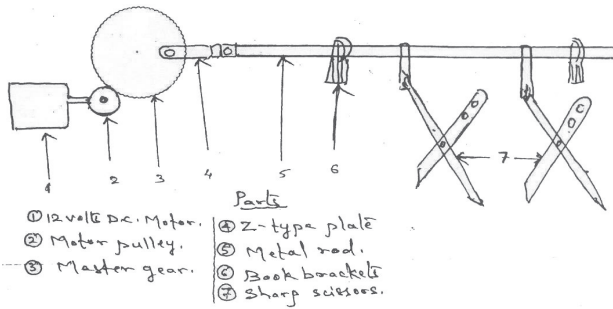
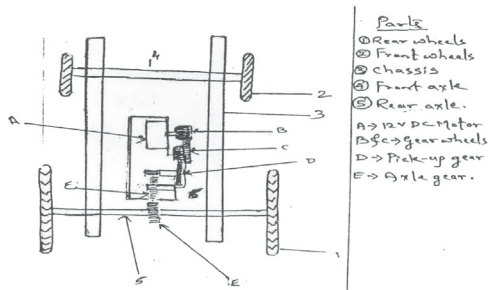

**Fig. 2: Solar Electric Crop Cutter**

A 12V D.C. motor is fitted to Z-type metal strip via two gears. The metal strips is connected to two sharp scissors. Electricity is generated when the input terminals are connected to the solar panel. This makes the motor to work and thereby the Z-plate starts moving in forward and reverse directions. The Scissors connected to this Z-plate start operating and hence the cutting process starts. The whole cutting machine is mounted on a plywood plate. The cutter is provided with a handle at the top and a switch just below the handle and a single rubber wheel at the front side, which helps us to move it very easily in the field.

## (C) SOLAR ELECTRIC TRACTOR

The whole model of tractor is prepared from the rectangular plastic strips. The working mechanism consists of a D.C. motor (12V) connected to a gear system. The gear system in turn is



**Fig. 3: Solar Electric Tractor**

connected to the rear wheels made of plywood. Power supply terminals of the motor are connected to a solar panel. When the sunlight falls on the solar panel, electricity is generated and when it is passed through the motor, the tractor moves. The tractor is fixed with the seed sowing and mud loosening mechanism at the rear side.

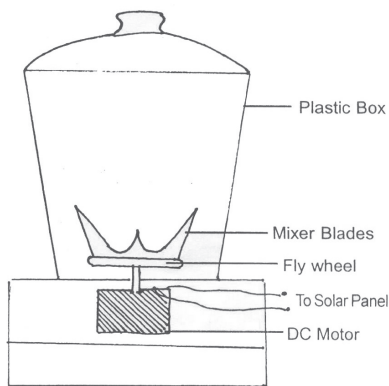

**Fig. 4: Solar Electric Mixer**

#### **(D) SOLAR ELECTRIC GRAIN MIXER**

A small 12V D.C. motor is fitted inside a plastic box. A blade set made from a nickel plate is fixed at the shaft of the motor. Another plastic box with a lid is fixed above the box with motor in it.

When the motor is connected to the solar panel kept in sunlight, the motor begins to rotate and hence the mixer starts working.

Solar electric mixer is used in different agricultural activities like mixing and grinding of seeds and grains.

#### **(E) SOLAR ELECTRIC SPRAY MACHINE**

A 12V D.C. motor is fixed at the front side of the shaft. The motor is then connected to a plastic wheel. The shaft is provided with a handle and a switch is provided just near the handle. A plastic water bottle fitted with a saline pipe should be kept above the level of the shaft. The motor when connected to the solar panel, starts working. When it starts working, the plastic wheel connected to it starts rotating and at the same time, water or liquid coming from the bottle via saline pipe spills on the rotating plastic wheel and hence it gets sprayed.

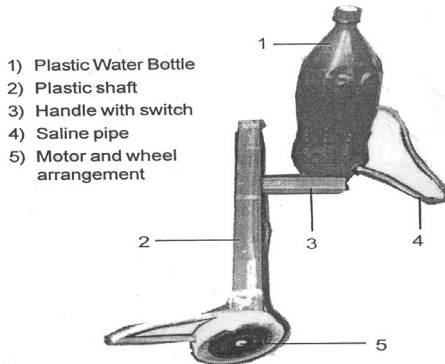

**Fig. 5: Solar Spray Machine**

**(F) SOLAR ELECTRIC FENCE**

The whole model is mounted on a wooden plate of size 3' × 1'. The connections are made as shown in Fig. 6. The positive and negative terminals of a 12V battery are connected to the copper wire wound around the border of the wooden plate (i.e., field). The wire is also connected to a speaker (buzzer) through an amplifier. The positive and negative terminals (wires) act as switches. When an animal touches these wires, circuit gets completed and that animal experiences a light shock and at the same time the buzzer begins to make sound. After hearing the sound the farmer comes out of his house and drives away the animals.

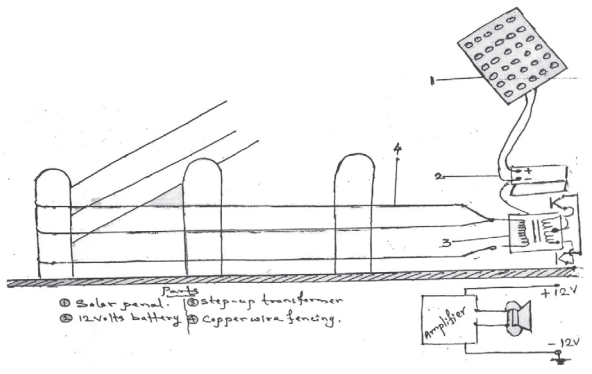

**Fig. 6: Solar Electric Fence**

**ADVANTAGES AND APPLICATIONS**

- (i) The present model ensures safe, economic and ecofriendly method of conserving energy resources (i.e., fossil fuels like diesel).

- (ii) The working models suggest an action plan to use the abundantly available and renewable source of energy like solar energy.
- (iii) In hot areas like our district Bijapur, Gulbarga, Raichur, Bidar and others these Solar agricultural equipments are very useful.
- (iv) Solar electric fence ensures safe way of protecting the crops from grazing animals.
- (v) The solar electric mixer can be easily used in different agricultural activities like mixing and grinding of seeds or grains.
- (vi) The solar electric tractor (sowing machine) can be used to sow the seeds and also to loosen the mud.
- (vii) The solar electric crop cutter can also be used to cut the unwanted plants and weeds of different heights.
- (viii) Grains like jawar, wheat, green grams and others can easily be separated from the unwanted mixture of grass, leaves and other dust particles.

**R.C.M.A. ROBO**

---

---

**STUDENTS**

Bagual Karan  
Mahale Vinit Sham

Madhya Railway Madhyamik  
Vidyalaya and Uchcha Madh.  
Vidyalaya. Manmad, Nasik,  
Maharashtra

**TEACHERS**

Dharrao Dhanjay Kedurao  
Kaarole Pravin Kumar Ram Chandra

---

---

**INTRODUCTION**

The word robot was coined by a Czech novelist Karel Capek in a 1920 play titled Rassum's Universal Robots (RUR). Robot in Czech is a word for worker or servant. A robot is a reprogrammable, multifunctional manipulator designed to move material, parts, tools or specialized devices through variable programmed motions for the performance of a variety of tasks: The introduction of robots can help in the development of sustainable agriculture to tackle the high costs of production that derive from increased labour costs and the observed shortage of labourers.

Developed agriculture needs to find new ways to improve efficiency. One approach is to utilise available information technologies in the form of more intelligent machines to reduce and target energy inputs in more effective ways than in the past.

The advent of (R.C)M.A. ROBO system gives us the opportunity to develop a complete new range of agricultural equipment based on small smart parts that can do the right thing, in the right place, at the right time in the right way.

The idea of robotic agriculture is not a new one. Many engineers have developed driverless tractors in the past but they have not been successful as they did not have the ability to embrace the complexity of the real world. Most of them assumed an industrial style of farming where everything was known before hand and the machines could work entirely in predefined ways, much like a production line.

The approach is now to develop smarter machines that are intelligent enough to work in an unmodified or semi natural

environment. These machines do not have to be intelligent in the way we see people as intelligent but must exhibit sensible behaviour in recognised contexts. In this way they should have enough intelligence embedded within environment, while carrying out a useful task.

The approach of treating crop and soil selectively according to their needs by small (R.C)M.A. ROBO system is the natural next step in the development of Precision Farming by taking a system approach, in which we consider a system in terms of its actions, interactions and implications. We have developed a new mechanisation system that collectively deals with all the crop's agronomic needs in a better way. To do this we must stop defining plant care in terms of the current mechanisation but in terms of what the plant needs. When we have defined the actual plant requirements we are then free to design a better way of dealing with them.

### **SCIENTIFIC PRINCIPLE INVOLVED**

- (i) Rotational motion is converted into mechanical energy. This mechanical energy is utilized for sprinkling pesticides and fertilizers along with sufficient amount of water.
- (ii) Solar energy is converted into electrical energy (solar energy is stored in 12V battery) where solar modules use light energy., i.e photons from the sun to generate electricity through the photovoltaic effect.

### **MATERIAL REQUIRED**

Used and recycled material such as bucket, tiffin box, funnel, tires, acrylic sheet, wooden frame, wire, plastic box, buttons, PVC pipes, solar panel, fan, battery, marker, salt bottle, lid, etc. used for making this exhibit.

### **CONSTRUCTION**

- (i) Four motors forming wheels for movement.
- (ii) A wooden frame as a base.
- (iii) A bucket where water is stored in a bottle.
- (iv) PVC pipes show movement due to which pesticides are sprayed.
- (v) Marker at the top acts as a sprinkler.
- (vi) Motor is used for lifting water.
- (vii) Hair dryer for dusting, fitted on wooden frame.

## WORKING

A Solar panel converts light energy into electrical energy where it is stored in 12V battery. This stored energy is used to operate motors fitted to wooden box by remote control. As the movement proceeds the another button of remote is operated at the same time for sprinkling of pesticides and fertilizers. Thus chemicals are sprayed to each and every plant so as to minimize its loss. When a motor starts rotating a hair dryer fitted at the back side of the robot, dust pesticides kill pest present on leaves as well on the plants. The cutters attached to the wheels start cutting weeds spreaded in the field since weeds also affects the growth of the plants.

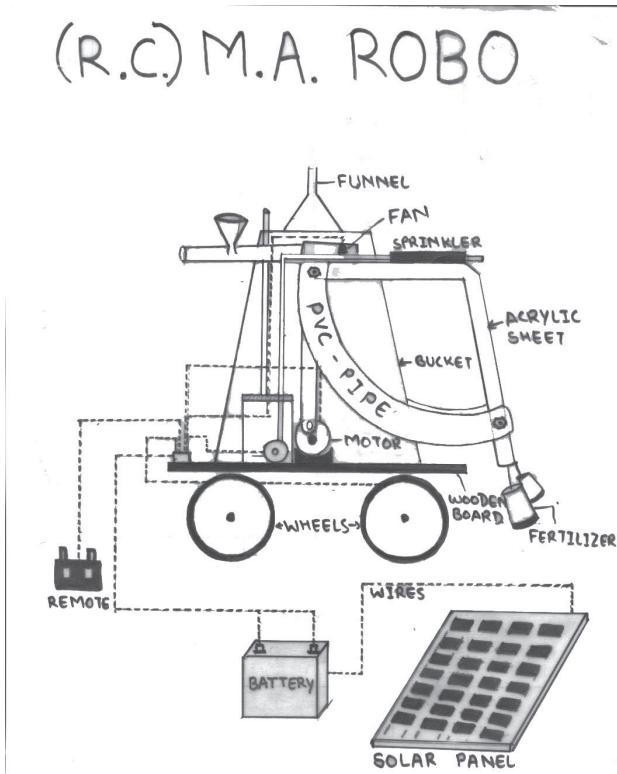

**Fig. 1: (R.C.) M.A. ROBO**

## **ADVANTAGES**

- (i) It saves time and money.
- (ii) Higher productivity.
- (iii) Eco-friendly.
- (iv) Easy to operate.
- (v) Inexpensive to use.
- (vi) Labour saving.

## **APPLICATIONS AND ECONOMIC PERSPECTIVES**

**General aspects:** Recently, the development of robotic systems in agriculture has experienced an increased interest, which has led many experts to explore the possibilities to develop more rational and adaptable vehicles based on a behavioural approach.

- (i) A combined application of new sensor systems, communication technologies, have enabled to develop new autonomous vehicles.
- (ii) The robots safety system would have to be reliable enough for it to operate autonomously and unattended.
- (iii) The small vehicles may also have less environmental impact replacing the over-application of chemicals and fertilizers, requiring lower usage of energy with better control that matched to requirements, as well as causing less soil compaction due to lighter weight.

## **Objectives**

Three main groups of field operations have been identified to be the first potential practical applications:

- (a) Crop establishment
- (b) Plant care
- (c) Selective harvesting.

Focus will be on potential labour cost savings, farm structure implications and sizes for operation, daily working hours, potential environmental impact, energy costs and safety issues.

## **Micro Spraying**

- (i) Micro spraying takes the concept of a spray boom down to the centimetre level it applies highly targeted chemicals and can treat small areas by selectively switching the jets on and off.
- (ii) It is part of a larger system that can recognise individual weed plants and locate their leaves for treatment. Trials

have shown that when herbicide is targeted in the right way at the right time, the usage can be drastically reduced.

- (iii) If this same approach can be carried out by an autonomous micro sprayer then there will be significant economic and environmental advantages.
- (iv) Within the close-to-crop area, great care must be taken not to damage the crop nor disturb the soil. The use of a micro spray that delivers very small amounts directly on to the weed.
- (v) Machine vision can be used to identify the position of an individual weed plant and a set of nozzles mounted close together can squirt a herbicide on to the weed.

## **CONCLUSIONS**

- (i) An initial outcome from this study indicates that most of these autonomous systems are more flexible than conventional systems and may reduce labour costs and restrictions on the number of daily working hours significantly.
- (ii) The initial investments and annual costs for expensive GPS systems are still relatively high but it seems possible to design economically viable robotic systems for grass cutting, crop scouting and autonomous weeding.
- (iii) Findings show that there is a significant potential for applying these systems if it is possible to impose adequate control and safety regulations systems at reasonable costs.

**CHAKRABYUHA****STUDENT**

Pinku Dash

Government Panchayat  
High School,  
Kushang, Bolangir,  
Odisha

**TEACHERS**

Bhagabatia Sahu  
Sarjan Negi

**INTRODUCTION**

Mathematics is not a difficult subject. Through regular practice, it can be applied in different fields as a result it will be easy, simple and funny as well as creates interest and curiosity.

Students show irritation towards Co-ordinate Geometry. As they think it is a difficult branch of mathematics. But a simple application of Co-ordinate Geometry can be seen in the “MAHABHARATA”. The “CHAKRABYUHA”, created by Guru Dronacharya, reflects an application of Co-ordinate Geometry. There is a model of “CHAKRABYUHA” situated in ancient ‘Shiv Temple’ of “Ranipur Jhariel” in Balangir District.

To introduce this ancient theory in the modern age of science and technology, we represent a mathematical project, that is: “APPLICATION OF CO-ORDINATE GEOMETRY IN CHAKRABYUHA”.

**OBJECTIVES**

To create interest of pupil in Co-ordinate Geometry and to inform public about the relationship between “CHAKRABYUHA and CO-ORDINATE GEOMETRY”.

**MATERIAL REQUIRED FOR GEOMETRICAL REPRESENTATION**

Plywood 2' × 2'; LED Ball – 300 nos.; Resistance – 60 nos; Transformer – 1 no.; Capacitor – 1 no.; Wire – 10 metres; Switch – 11 nos.; Diode – 4 nos.

## MATERIALS REQUIRED

Plywood —  $2' \times 2'$ ; Magnet 8 pieces; Dolls 9 and 9 Carts for Abhimanyu, Saptarathi and Jayadratha; Plastic Sticks - 2 packets.

## CONSTRUCTION OF CHAKRABYUHA BY USING CO-ORDINATE GEOMETRY

'X' and 'Y' axes are drawn on a graph paper and intersecting at origin 'O'.

The point 'P' and 'R' are taken in X- axis, and 'Q' and 'S' are in Y- axis

The Co-ordinates of 'P' is (2, 0)

The Co-ordinates of 'R' is (-2, 0)

The Co-ordinates of 'Q' is (0, 3)

The Co-ordinates of 'S' is (0, -2)

In 1st quadrant A,B,C

2<sup>nd</sup> quadrant D, F2, F, C1

3<sup>rd</sup> quadrant GHIP<sub>14</sub>

4<sup>th</sup> quadrant J,K,L points are taken and their co-ordinates have been marked as:

A = (2, 3)	G = (-2, -1)
B = (2, 2)	H = (-2, -2)
C = (2, 1)	I = (-2, -3)
D = (-2, 3)	P <sub>14</sub> = (-2, -4)
E = (-2, 2)	J = (2, -1)
F = (-2, 1)	K = (2, -2)
C1 = (-1, 3)	L = (2, -3)

Here we have to observe that:-

The points A, B, C, P, J, K, L lie on the equation of the graph L<sub>1</sub>, where X=2, Similarly the points D, E,F,R,G,H,I,P<sub>14</sub> lie on the equation of the graph 'L<sub>2</sub>' where X=-2, and the points D, C1, Q, A lie on the equation of the graph L<sub>3</sub>, where Y=3

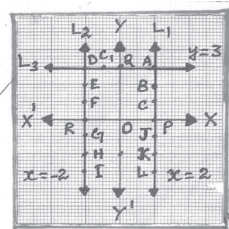
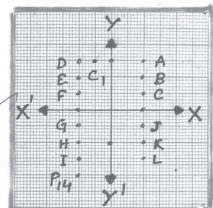
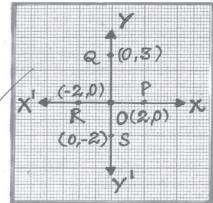
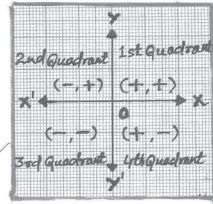

By taking B as centre  $\widehat{AC}$  semicircle

By taking E as centre  $\widehat{DF}$  semicircle

By taking H as centre  $\widehat{GI}$  semicircle

By taking K as centre  $\widehat{JL}$  semicircle

By taking  $C_1$  as centre semi circle are drawn

The points of the equation of the graph  $Y=3$ ,  $C_2, P_1, P_2, P_3, P_4, P_5, P_6, P_7, P_8, P_9, P_{10}, P_{11}, P_{12}$  and  $P_{13}$  are taken on the line  $L_3$ . The Co-ordinates of these points are given below:

Points	Co-ordinate
$C_2$	$(-1/2, 3)$
$P_1$	$(-3, 3)$
$P_2$	$(-4, 3)$
$P_3$	$(-5, 3)$
$P_4$	$(-6, 3)$
$P_5$	$(-7, 3)$
$P_6$	$(-8, 3)$
$P_7$	$(-9, 3)$
$P_8$	$(3, 3)$
$P_9$	$(4, 3)$
$P_{10}$	$(5, 3)$
$P_{11}$	$(6, 3)$
$P_{12}$	$(7, 3)$
$P_{13}$	$(8, 3)$

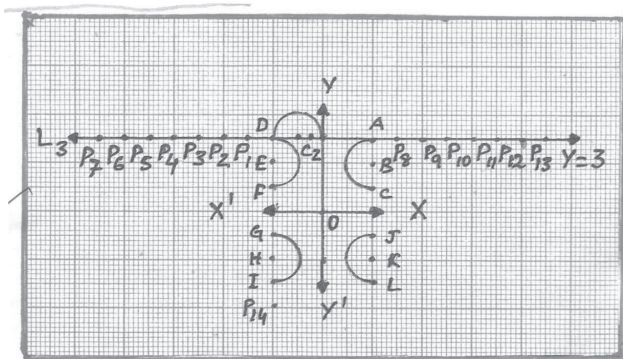
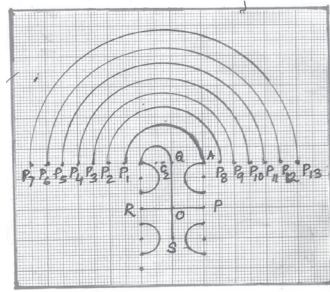

The semicircles

- $\widehat{P_1, A}$
- $\widehat{P_2, P_8}$
- $\widehat{P_3, P_9}$
- $\widehat{P_4, P_{10}}$
- $\widehat{P_5, P_{11}}$
- $\widehat{P_6, P_{12}}$
- $\widehat{P_7, P_{13}}$

are drawn by taking 'C<sub>2</sub>' as centre.

The arc

- $\widehat{B P_8}$
- $\widehat{C P_9}$
- $\widehat{P P_{10}}$
- $\widehat{J P_{11}}$
- $\widehat{K P_{12}}$
- $\widehat{L P_{13}}$

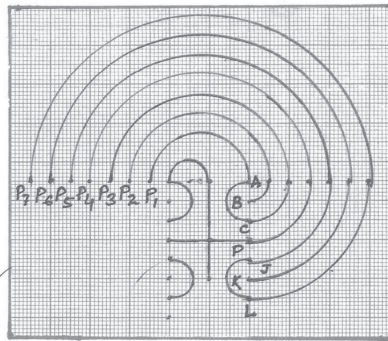

are drawn by taking 'A' as centre.

The arc

- $\widehat{E P_1}$
- $\widehat{F P_2}$
- $\widehat{R P_3}$
- $\widehat{G P_4}$
- $\widehat{H P_5}$
- $\widehat{I P_6}$
- $\widehat{I P_7}$
- $\widehat{P_7 P_{14}}$

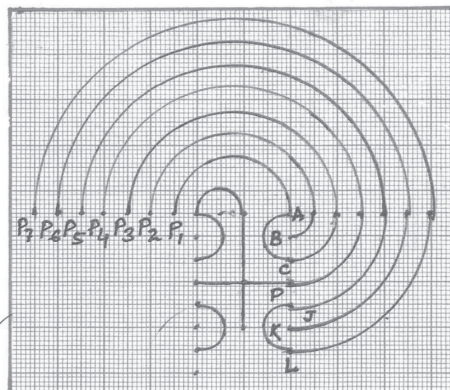

are drawn by taking 'D' as centre.

At last in 3rd quadrant arc  $\widehat{P_{14}S}$  is drawn by taking 'H' as centre for completion of CHAKRABYUHA.

### **Construction for Geometrical Representation**

The diagram of Chakrabyuha is drawn on (2' x 2') Plywood. The LED balls are arranged on the line of the diagram, for every 5 LED balls one resistance is connected. In this way, 300 LED balls are arranged for smooth functioning of the model. One transformer (12 volts), one capacitor (1.5 microfarad) and 4 diodes are connected. There are 11 Switches  $S_1, S_2, S_3, S_4, S_5, S_6, S_7, S_8, S_9, S_{10}$  &  $S_{11}$  connected to operate this model.

### **FUNCTION OF SWITCH**

When  $S_1$  switch is on, all the balls of X and Y axis glow.

When  $S_2$  switch is on, A, B,C,D,E,F,G,H,I,J,K,L and  $P_{14}$  balls glow.

When  $S_3$  switch is on, balls of the semicircles  $\widehat{AC}, \widehat{DF}, \widehat{DQ}, \widehat{DG}, \widehat{GI}$  and  $\widehat{JI}$  glow.

When  $S_4$  switch is on, ball of the point  $P_1, P_2, P_3, P_4, P_5, P_6, P_7, P_8, P_9, P_{10}, P_{11}, P_{12}$  and  $P_{13}$  glows.

When  $S_5$  switch is on, ball of the semicircle  $\widehat{P_1A}$  glows.

When  $S_6$  switch is on, balls of the semicircle  $\widehat{P_2P_8}, \widehat{P_3P_9}, \widehat{P_4P_{10}}, \widehat{P_5P_{11}}, \widehat{P_6P_{12}}$  and  $\widehat{P_7P_{13}}$  glow.

When  $S_7$  switch is on, balls of the arc  $\widehat{BP_8}$  glow.

When  $S_8$  switch is on, balls of the arc  $\widehat{CP_9}, \widehat{PP_{10}}, \widehat{JP_{11}}, \widehat{KP_{12}}$  and  $\widehat{LP_{13}}$  glow.

When  $S_9$  switch is on, balls of the arc  $\widehat{EP_1}$  glow.

When  $S_{10}$  switch is on, balls of the arc  $\widehat{FP_2}, \widehat{RP_3}, \widehat{GP_4}, \widehat{HP_5}, \widehat{IP_6}$  and  $\widehat{P_{14}P_7}$  glow.

When last switch ' $S_{11}$ ' is on, balls of the arc  $\widehat{P_{14}S}$  glow.

In this way all the balls of the Chakrabyuha are glown by operating all switches.

### **CONSTRUCTION OF CHAKRABYUHA**

Plywood (2' x 2') is kept horizontal to the plane. There is a picture of Chakrabyuha drawn on the plywood. The Plastic sticks are

arranged as security on the line of the diagram as like soldiers. Chariot of Jayadratha is kept at the entrance of the Chakrabyuha, the north-pole of the magnet is kept in front of the chariot of the great warriors Drona, Karnna, Shalya Krupacharya, Bhumishrabe, Duryodhan and Ashwatthama, both the north-pole of magnet repel due to the chariot of Abhimanyu and other seven warriors come face to face. Abhimanyu's chariot shows greater repulsive force because it has high magnetic substance. So all chariots go backward when Abhimanyu's chariot comes closer to them.

### **Entry of Abhimanyu in Chakrabyuha**

- When Abhimanyu passes through the entrance he faces Jayadratha at origin  $O(0,0)$ . Abhimanyu defeats Jayadratha in the battle and host his flag of victory on his locus. In the end Hayadratha closed the entrance of CHAKRABYUHA.
- Abhimanyu faces the 1<sup>st</sup> Rathi, Drona at point  $(-1, 9)$  of Cartesian plane, on continuing their fight Drona moves backward by Abhimanyu's attack.
- The Abhimanyu faces the 2<sup>nd</sup> Rathi, Karnna at the point  $(-1, 10)$ , from that point both Drona and Karnna fight with Abhimanyu and they also move backward.
- Then Abhimanyu faces the 3<sup>rd</sup> Rathi Shalya at the point  $(-1, 11)$ , from that point Drona, Karna and Shalya are defeated by Abhimanyu and move backward.
- Then Abhimanyu faces the 4<sup>th</sup> Rathi, Krupacharya at the point  $(-1, 8)$  and from that point Drona, Karnna, Shalya and Krupacharya are defeated by Abhimanyu and move backward.
- Then Abhimanyu faces the 5<sup>th</sup> Rathi, Bhumishraba at the point  $(-1, 5)$ , from that point Drona, Karnna, Shalya, Krupacharya and Bhumishraba are defeated by Abhimanyu and move backward.
- Then Abhimanyu faces the 6<sup>th</sup> Rathi Duryodhan at the point  $(-1, 6)$  from that point Drona, Kranna, Shalya Krupacharya, Bhumishraba and Duryodhan are defeated by Abhimanyu and move backward.
- Abhimanyu faces the 7<sup>th</sup> Maharathi Ashwatthawa at point  $(-1, 7)$  of  $X = -1$  equation, from that point the SAPTA RATHI are defeated by Abhimanyu and move backward.

- In such a way, Abhimanyu reaches the Centre place of the Chakrabyuha. However, Abhimanyu didn't know how to come out, but it was known to the Saptarathi, so they took Abhimanyu in a wrong path. In the end they closed the return path by standing at a line between the points (-2,0) and (-2,1).
- By standing together
  - » Their confidence level increases.
  - » By the command of Duryodhan they attack Abhimanyu.
- Through which point Abhimanyu enters to the Charkrabyuha at the same point, i.e. the origin (0,0) he is killed by the "SAPTARATHI".
- If Abhimanyu knew that 'X' and 'Y' axis intersect each other at the one and only one point 'O', then he would have displayed a soldier at that point and come out from the "CHAKRABYUHA" through entrance.

### **CO-ORDINATES OF THE SAPTARATHI AND JAYADRATHA**

- The Co-ordinates of the SAPTARATHI are taken in equation  $X=-1$ .
- The Co-ordinate of the JAYADRATHA is taken in the midpoint of P and J.
- The symbol  $\rightarrow\rightarrow\rightarrow$  are taken as the locus of Abhimanyu which is given in the table.

<b>Sl.No.</b>	<b>Name of the great Warrior</b>	<b>Co-ordinates of the great warrior in the equation <math>X=-1</math></b>
1	Drona	(-1,9)
2	Karnna	(-1, 10)
3	Shalya	(-1, 11)
4	Krupacharya	(-1,8)
5	Bhurishraba	(-1,5)
6	Duryodhan	(-1,6)
7	Ashwatthama	(-1,7)
8	Jayadratha	(2, -1/2)
9	The Great Abhimanyu	$\rightarrow \rightarrow \rightarrow$ Locus

# Construction of CHAKRABHYUHA

Application of  
Co-ordinate  
Geometry and  
locus

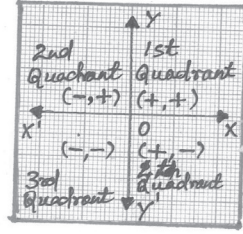

Construction of x - a xis , y-axis and origin in a plane

Construction of CHAKRABHYUHA by the help of plane, Co-ordinate, Geometry, arc and the eqn. of X and Y

By taking 'D' as Centre EP<sub>1</sub>, FP<sub>3</sub>, EP<sub>3</sub>, GP<sub>1</sub>, AP<sub>6</sub>, IP<sub>6</sub>, P<sub>7</sub>, P<sub>14</sub>  
 By taking 'A' as Centre BP<sub>8</sub>, CP<sub>9</sub>, PP<sub>10</sub>, JP<sub>11</sub>, KP<sub>12</sub>, LP<sub>13</sub>  
 By taking 'H' as Centre P<sub>14</sub>S Arc are drawn for the construction of Complete.  
**CHAKRABHYUHA**  
 The Co-ordinates of SAPTARATHI are taken in Y = -1 eqn.  
 And The Co-ordinates of JAYADRATHA in taken in mid - point of pond J,

Plane is a set of infinite points  
 $\Rightarrow \{(x, y) | x, y \in \mathbb{R}\}$   
 There is a order pair of every point in the Co-ordinate plane  
 $\Rightarrow \{(x, y) \in \mathbb{R}^2\}$

Accesible

Observation

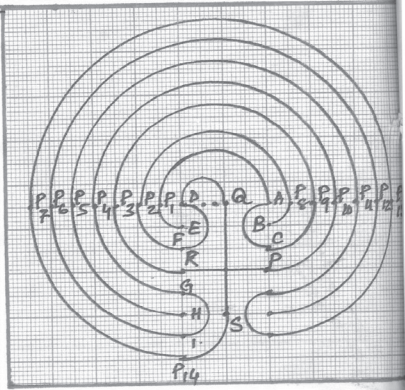

Not Accesible

Limitation of CHAKRABHYUHA  
 Equality of no. of soldier and no. of points.  
 $\propto \rightarrow \text{nts} = \infty \text{ Soldier}$   
 Accuracy of Co-ordinates of the SAPTARATHI

Construction of Geometrical Figure  
 By the help of Co-ordinates

Real fact

## MULTIPURPOSE QUALITIES OF SOAPNUT

---

---

### STUDENTS

Nabadeep Borgohain  
Mukunda Madhab Boruah

Kiran Academy,  
Dhemaji, Assam

---

---

### INTRODUCTION

The rich biodiversity of the earth gives us food, shelter and nourishes all. But, some people don't realise this and exploit her for urbanisation, agriculture and poaching, etc. As a result, the existence of plants and animals are always vulnerable to extinction. The traditional methods of acquiring essential goods from nature don't pose any threat to nature. But the unplanned methods of acquiring the natural goods pose great threat to her. Besides this, due to the ignorance and lack of awareness on the conservation policies the biodiversities of the world have been exploited beyond its sustainability.

So, in regard to these things we decided to prepare a project on "SOAPNUT TREE".

We have surveyed 30 people dividing into three age groups each of 10 people, i.e 10-30 years, 30-60 years, 60-100 years.

Generally SOAPNUT tree is a wild tree and they are used in various applications. People plant them in their homes. Once this tree was found in every house of Assam, but now they are on the verge of extinction.

Through our survey we found the medicinal as well as economical importance of this tree. The probable economic benefits and other some uses of this tree are given below:

- **TONSIL:** Dry powder of Soapnut tree is mixed with half boiled water and gargled to get rid of tonsil.
- **SKIN DISEASE:** Dry powder of Soapnut is mixed with water and applied on the skin to cure any skin disease.

- **DANDRUFF:** Shampoo of Soapnut is used to get rid of dandruff.
- **ASTHMA:** Seed of Soapnut is used with black paper, “manimuni”, honey and a special kind of earthworm found inside the bark of bheem banana tree to get rid of asthma.
- **PESTICIDES:** The CEPNINE material present in the seed of Soapnut reacts with lower classes of organism, it can be used as a pesticide.
- **SOME OTHER USES:** Detergent can be made from the seed of Soapnut. Bark of the Soapnut tree can be used as a fertilizer. The seed of Soapnut can also be used as tooth powder.

This tree with great economic and medicinal use is now on the way of extinction. So, in our surveyed areas we request all the people and “NGO” to take steps for the conservation of Soapnut tree. We hope this small step will help in the conservation of this tree.



**Fig. 1: Soapnut Tree**

### **PROCEDURE**

We decided to prepare our project in experimental and survey method. We prepared some questions for our survey. These are given below:

1. Have you ever seen a soapnut tree?
2. Do you have soapnut tree in your house?
3. Is it wild or people planted tree?

4. Does it blooms flower?
5. Do you know about the great uses of the soapnut tree in our day-to-day life?
6. Do you know the tree of Soapnut and for what purposes the seed is being used?
7. Do you know that some useful products can be made at home for our daily use?
8. Do you know about the economic importance of this tree?
9. Do you think this tree can help in sloving the problem of unemployment in our society?
10. Do you know that the tree can be used as a fuel as well, and we get a very good quality of coal?
11. Do you think that things such as shampoo, detergent, toothpowder can be prepared from the seed of Soapnut?
12. Do you think that bark of Soapnut tree can be used as a fertilliser?
13. Do you know about the medicinal uses of this tree?
14. Is the ancient use of this tree known to you?

### **RESULT (SURVEY)**

The details of survey result is given below:

#### **List: 1 (Age 10 -30 years)**

1.	i.	Yes	1	10%
	ii.	No	9	90%
2.	i.	Yes	0	0%
	ii.	No	10	100%
3.	i.	Wild	0	0%
	ii.	People Plant	1	10%
	iii.	Do not Know	9	90%
4.	i.	Know	9	10%
	ii.	Do not Know		90%
5.	i.	Yes	0	0%
	ii.	No	10	100%
6.	i.	Yes	0	0%
	ii.	No	10	100%
7.	i.	Yes	0	0%
	ii.	No	10	100%
8.	i.	Yes	0	0%
	ii.	No	10	100%

9.	i.	Yes	0	0%
	ii.	No	10	100%
10.	i.	Yes	5	50%
	ii.	No	5	50%
11.	i.	Yes	0	0%
	ii.	No	10	100%
12.	i.	Yes	0	0%
	ii.	No	10	100%
13.	i.	Yes	0	0%
	ii.	No	10	100%
14.	i.	Yes	1	10%
	ii.	No	9	90%

**List: 2 (Age 30-60 years)**

1.	i.	Yes	6	60%
	ii.	No	4	40%
2.	i.	Yes	0	0%
	ii.	No	10	100%
3.	i.	Wild	4	40%
	ii.	People Plant	2	20%
	iii.	Do not Know	4	40%
4.	i.	Yes	6	60%
	ii.	Know	0	0%
	iii.	Do not Know	4	40%
5.	i.	Yes	6	60%
	ii.	No	4	40%
6.	i.	Yes	6	60%
	ii.	No	4	40%
7.	i.	Yes	6	60%
	ii.	No	4	40%
8.	i.	Yes	6	60%
	ii.	No	4	40%
9.	i.	Yes	5	50%
	ii.	No	5	50%

10.	i.	Yes	6	60%
	ii.	No	4	40%
11.	i.	Yes	6	60%
	ii.	No	4	40%
12.	i.	Yes	3	30%
	ii.	No	7	70%
13.	i.	Yes	0	0%
	ii.	No	10	100%
14.	i.	Yes	6	60%
	ii.	No	4	40%

**List: 3 (Age 60-100 years)**

1.	i.	Yes	9	90%
	ii.	No	1	10%
2.	i.	Yes	2	20%
	ii.	No	8	80%
3.	i.	Wild	5	50%
	ii.	People Plant	4	40%
	iii.	Do not Know	1	10%
4.	i.	Know	9	90%
	ii.	Do not Know	1	10%
5.	i.	Yes	9	90%
	ii.	No	1	10%
6.	i.	Yes	9	90%
	ii.	No	1	10%
7.	i.	Yes	9	90%
	ii.	No	1	10%
8.	i.	Yes	6	60%
	ii.	No	4	40%
9.	i.	Yes	5	50%
	ii.	No	5	50%
10.	i.	Yes	7	70%
	ii.	No	3	30%
11.	i.	Yes	8	80%
	ii.	No	2	20%

12.	i.	Yes	6	60%
	ii.	No	4	40%
13.	i.	Yes	8	80%
	ii.	No	2	20%
14.	i.	Yes	10	100%
	ii.	No	0	0%

From our surveyed report we came to know some facts and ancient uses of this tree and from the surveyed knowledge we tried and prepared some products. The methodologies of these products are given below:

**Dry Shampoo:** In preparing dry shampoo, 30gm of dry powder of Soapnut tree is mixed with 10gm of peak of China Rose and for better smell of the shampoo, 5 gm of sandalwood or bokul flower is mixed. We have to keep this shampoo dry in order to keep it away from fungus.

**Detergent:** In preparing detergent, 30gm of dry powder of soapnut tree is mixed with 5 gm of sandalwood or bokul flower for better smell of the detergent.

**Pesticides:** Peel of the Soapnut seed can be used as a pesticide instead of DHUNA.

**Tooth Powder:** In order to prepare tooth powder, 20 gm dry powder of soapnut tree is mixed with 5 gm of JASTHA MADHU for the sweet taste.

We got the following results after using the products.

- (i) After using the shampoo we made, the hair became softer and stronger. We also found the hair become dandruff free.
- (ii) When we used the pesticides we found that insects, lizard were in much less number compared to before the experiment. Also the smell of this pesticide is better than other pesticides available in the market.
- (iii) The detergent of the Soapnut tree is found to be of good quality, and also it can be used for washing gold and other metallic ornaments.
- (iv) The toothpowder made from Soapnut tree is found to be a better toothpowder and it also cures various tooth problems and also helps to cure tonsil.

## ENVIRONMENTALLY SAFE WOOD STOVE

---

### STUDENTS

Kavya S. Kumar  
Jhanavi H.B

Empress Government  
P.U. College,  
Tumkur, Karnataka

### TEACHER

A. Ramaswamy

---

### INTRODUCTION

Indoor air pollution emitted from traditional fuels and cooking stoves possesses health hazard for rural people. Over 72 per cent of all households in India and 90 per cent of households in the country's poor, rural areas use traditional solid fuels such as crop residue, cowdung and firewood to meet their cooking needs (Census of India, 2001). The burning of solid fuels indoors, in open fires or traditional cooking stoves (*chulhas*) results in high levels of toxic pollutants in the kitchen area. As such, the use of these fuels are considered a major risk factor for lung cancer as well as cardiovascular and respiratory disease. The emissions rates of pollutants from traditional stoves are extremely high.

The smoke from burning solid fuels also produces many other pollutants including particulate matter (PM) and carbon monoxide (CO), that are known to be highly toxic.

The burning of solid fuels produces these matters due to imbalance between supply of air and rate of combustion. Supply of sufficient air in wood stove leads to complete combustion and reduces particulate matter and carbon monoxide.

We have designed a wood stove for complete combustion of wood by supplying additional air.

### CONSTRUCTION AND WORKING

The wood stove consists of two concentric cylindrical tin chambers with open lids, which are separated by 3 to 5 mm gap between them. Inner cylindrical combustion chamber placed on circular ring in the bottom of the outer cylinder. Few holes are

made on the side wall of the inner cylinder at a height of 3cm above its bottom.

A side tube in the outer chamber at its bottom is fitted with a fan with a D.C motor.

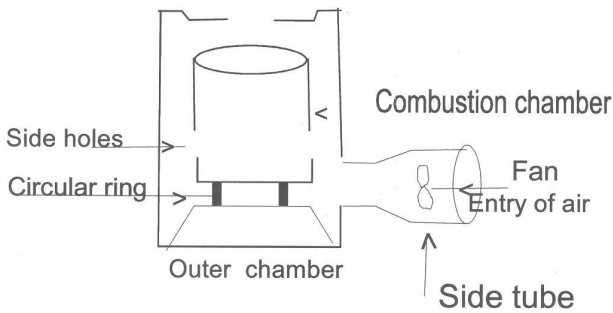
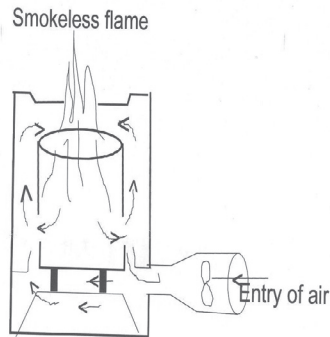

**Fig. 1: Combustion Chamber**

The air from fan does not enter directly into the combustion chamber but rises in the gap between chambers. The fast moving air from the fan creates negative air pressure in the gap between the boxes. This sucks the wood gas from the combustion chamber. Wood gas mixes with the incoming air. Mixture of air and wood gas moves up in the gap to the top of combustion chamber and burns with smokeless flame at the top.

**ADVANTAGES**

- (i) This model is low cost, uses locally available materials, simple technology and maintenance free.
- (ii) It is a boon for rural areas using wood for cooking purpose.
- (iii) It is eco-friendly, makes use of renewable source of energy and also saves forest.



**Fig. 2: Wood Stove**

## POLLUTION FREE COOL HOUSE

---

**STUDENT**

Sanjib Bora

Garigaon High School,  
Golaghat, Assam**TEACHER**Hema Kt. Gogoi

---

**INTRODUCTION**

Climate change has become the most important subject for human being in this modern world. Global warming is one of the main causes of this climate change. If human beings do not resist this, then it seems that the world is going on the path of devastation.

Some kind of gases have been unnaturally added in air as human beings have been emitting it without much deliberation for their own comforts. Among these are Green house gases such as Carbon dioxide ( $\text{CO}_2$ ), Methane ( $\text{CH}_4$ ), Nitrous oxide ( $\text{N}_2\text{O}$ ), Chlorofluorocarbon (CFC) etc.

This project attempts to prepare a pollution free cool house. Through this project, we want to show how we can keep our rooms cool without producing Green House Gas thereby leading our environment to a sustainable path.

**SCIENTIFIC PRINCIPLE INVOLVED**

*Cooling Effect Due to Evaporation:* The molecules of a liquid are always in a state of random motion. They collide with each other and they may or may not change their respective kinetic energies. Due to collisions certain molecules may acquire more energy than the average energy with which it is held. As soon as this happens the molecules leaves the liquid surface. This is called evaporation. When the molecules of the liquid transforms into gaseous state, they have to absorb heat energy from the surroundings. As a result the temperature of the surroundings decreases. Here wind energy provides energy for evaporation of liquid present in the thread, for which temperature of the room becomes lower as compared to outside.

## POLLUTION FREE COOL HOUSE

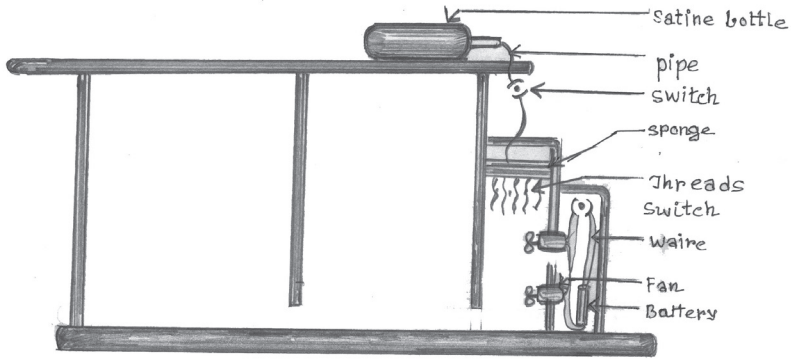

**Fig. 1: Pollution Free Cool House**

### **MATERIAL REQUIRED**

A fish keeping box of thermocol; A piece of thermocol; Battery; Electric Motors; Fans; Conducting wire; Scissor; Blade; Gum; Sponge; Switch; Bamboo sticks; Threads; Needle; A saline bottle with pipe.

### **CONSTRUCTION AND WORKING**

To prepare this project, a fish box of thermocol is cut with measurement and it is stuck by gum in the model of RCC house. The model is separated into two parts by cutting a piece of thermocol, on one side a small air cooler room is prepared and two holes are made on the two walls. Two fans are connected to two electrical motors and these are kept on the outside of the wall of the aircooler room and it is connected with wire, switch and battery. Two sticks are stuck on the upper side of the motor and a sponge is kept there and some threads are hanging from it.

A saline bottle with a pipe is kept on top of the model. The pipe directly comes to the sponge and through the pipe water flows from the bottle and it wets the sponge and threads. For this, the open side of the pipe was closed and on the sponge side, holes were made with the help of needle. A controller is fitted on the pipe of the saline bottle to control the water flow through the sponge and the threads. The droplets of water are

made to flow into the room with the help of the fans. The air in the room becomes damped with water vapour. The air which is saturated with water vapour moves to the other room through the two holes and the room becomes cooler.

### **APPLICATIONS**

Pollution free cool house has applications for various purposes. These are listed below:

- (i) It can be used in household purpose in our daily life.
- (ii) Pollution Free Cool House can be used in the classroom of a school.
- (iii) It can also be used in meeting, gathering, auditorium or hall etc.
- (iv) It can be put in automobiles, vehicles, etc.

## DROWNED ARTICLE SEARCHER

---

---

**STUDENT**

Sarkar

South Jumerdhepa  
High Arjun School,  
Sonamura Sepahijala,  
Tripura

**TEACHER**Amit Kumar

---

---

**INTRODUCTION**

If any valuable object/article is lost in water of a tank or pond it is very troublesome to search it out. For this, an instrument have been developed which make it possible to search out the lost article easily. Naturally the water of different tanks become muddy when we start searching. As a result light cannot pass through muddy water and the drowned article becomes invisible. If we immerse a tube filled with air in water fitted with LED light then the lost article can be made visible through the tube.

**CONSTRUCTION AND WORKING**

We take a pipe which is one feet longer than the depth of water. A convex lens and an LED are fitted in one end of the pipe. The convex lens must be fitted in such a way that water cannot enter into the pipe when the pipe is immersed in the water. The LED light can be controlled from outside the water, i.e. from upper portion of the pipe with the help of switch. Now the article under the water will be visible if we immerse the lens attached side of the pipe under water after switching on the light. When we look through the upper portion of the pipe, the article under the water becomes visible.

**DISCUSSION**

While discussing regarding the passing of light through different mediums, our teacher one day said- 'The muddy water is not transparent and light cannot pass through it'. After that I seriously thought about the matter. Besides, one day I lost my bicycle key in the water of a pond of 'Nandipara' in the village

Jumerdhepa. The need for developing some kind of instrument came in my mind while I was thinking to search the key. Then I made this instrument and on the next day I searched the key and found.



**Fig. 1: Drowned Article Searcher**

#### **ADVANTAGES**

- (i) It is a very low-cost instrument ( ₹ 85 only).
- (ii) The drowned valuable articles (Jewels etc.) can be recovered by a simple method which is also low cost.
- (iii) It is pollution free instrument.
- (iv) Very low energy is needed for this instrument.
- (v) This instrument is made up of simple technology.

# INTELLIGENT AMBULANCE AND MULTIPURPOSE TRAFFIC SIGNAL

---

**STUDENTS**

Jaya Krishnan  
Sooraj Tom  
Neeraj Ramchandra  
Nithin M. Thomas

Jawahar Navodaya  
Vidyalaya, Vadavathoor,  
Kottayam, Kerala

**TEACHER**

V. Ramdas

---

**INTRODUCTION**

The intelligent traffic control system (ITCS) and multipurpose traffic signal (MPTS) is developed mainly for reducing traffic problems faced by emergency services such as ambulance, fire engine, etc. Although this ITCS/MPTS will be effective in all cities, it will have more utility in metro cities where there is huge traffic congestion.

**OBJECTIVE**

The project is aimed at:

- (i) Improvising 'ambulance services (emergency services)/ traffic control system' (ITCS) to ensure a clear traffic free road, and
- (ii) Developing a traffic signal which is better than the existing one, durable, easy to use and operate and having variety of functions/applications.

**MATERIAL REQUIRED****Ambulance Alert**

Diodes-IN4148 – 4 nos; Transistors (BC547) – 4 nos; Resistors –270k $\Omega$ , 220k $\Omega$ , 56k $\Omega$ , 18 $\Omega$  – 1 no. each; 330 $\Omega$ , 10k $\Omega$  – 2 no. each; 1k  $\Omega$  – 1 no; Capacitors – 100nF, 47nF, 1000 $\mu$ F – 1 no. each; 10nF – 2 no; 8 $\Omega$  speaker; Red LED – 3V; 9V battery; 12V Relay, etc.

### **Burglar alert**

IC-NE555 – 1 no; Soft touch switch – 2 no; LED-3V – 1 no; Buzzer-6V – 1.

### **Fire Alert**

Transistor (BC547) –1 no; Resistors – 47K $\Omega$ , 4.7K $\Omega$  – 1 no each; 1 K $\Omega$  –2 no; Capacitors – 100 $\mu$ F –1; 10nF –2; Diode (IN4148); IC-NE555; 8 $\Omega$  Speaker; 9V Battery –1.

### **Emergency Notification**

IC-NE555 –1 no; Soft touch switch –2 no; LED-3V –1 no; Buzzer –6V –1no.

## **USES AND APPLICATIONS OF VARIOUS COMPONENTS**

1. Metal detector – to detect the arrival of the ambulance.
2. 12V Relay – to switch between the red and green signals.
3. Fire alarm – to detect fire in the building.
4. NE555 Switching circuit – to detect any emergency situation (burglary) inside the ATN counter and to trigger alarm at the PCR from the traffic signal.

### SCHEMATIC DIAGRAMS/ CIRCUITS

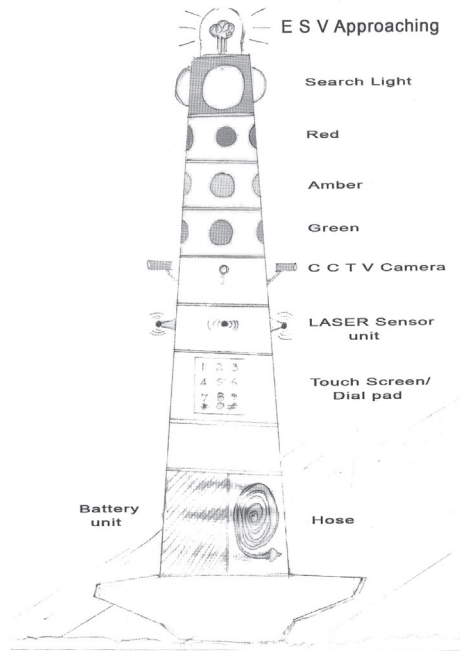

**Fig. 1: Schematic Circuit Diagram**

## WORKING

The driver of an emergency service vehicle (ESV) will activate the ITCS/MPTS on his route, which in turn will alert the PCR as well as the police personnel around the activated ITCS/MPTS. The ITCS/MPTS will glow RED in all four directions. The traffic in all the directions are regulated or controlled and the ESV can travel freely towards its destination.

After the ESV passes one ITCS/MPTS, now the job of activating the subsequent ITCS/MPTS is taken over by the PCR who is able to view the movement of the ESV.

In the case of a burglary or fire in a building/shop/ATM counter around a particular ITCS/MPTS, the ITCS/MPTS gets activated, the search lights turn on, a siren is automatically switched on, an alert is received at the PCR and the police personnel on duty in the area near the activated ITCS/MPTS can be alerted. The area where an untoward incident has taken place can be easily located and the spot can be reached and rescue operations can be initiated without wasting much time.

Multifunction of ITCS/MPTS

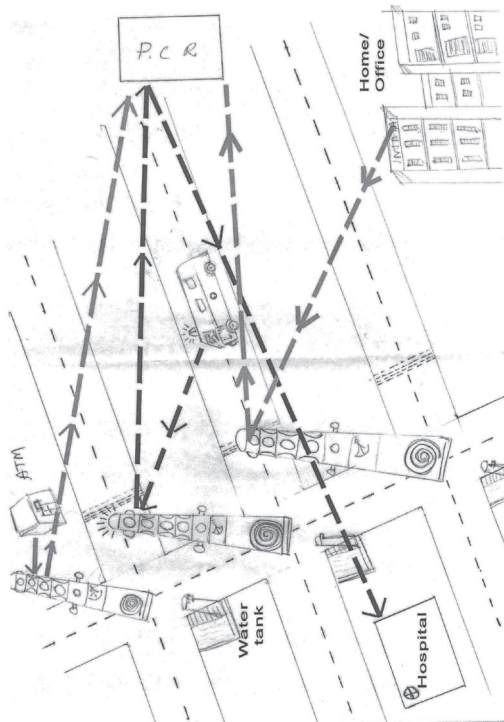

**Fig. 2: Multifunction of ITCS/MPTS**



**Fire Alert:** The house is fitted with a zener diode. Whenever there is a fire, the zener diode triggers the circuit. The circuit forwards the warning to the PCR and necessary actions can be taken immediately.

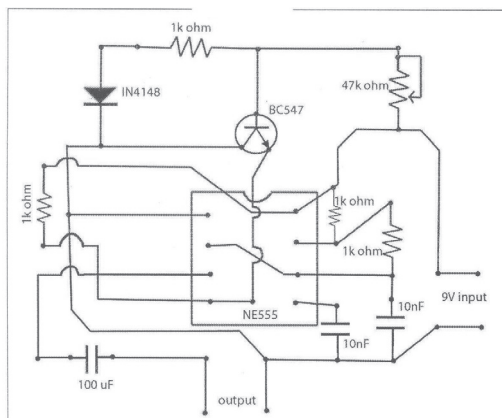

**Fig. 5: Fire Alert Circuit**

**Burglar Alert:** The ATM counter is fitted with a soft touch switch which is connected to the 'trigger' pin of NE555 IC. As soon as the switch is pressed, it triggers an alert in the PCR, and a siren is raised at the traffic signal. The alert can be reset only by a reset button provided at the PCR.

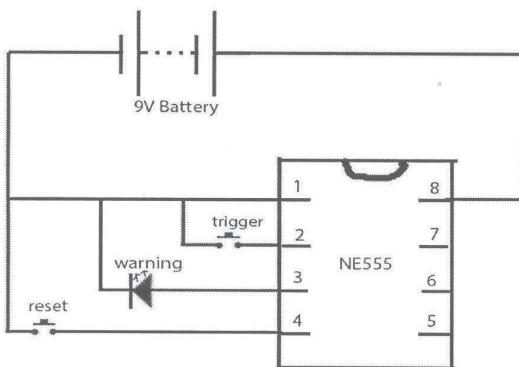

**Fig. 6: Burglar Alert Circuit**

**Emergency notification:** The traffic signal has a soft touch switch on it which is connected to the 'trigger' pin of NE555 IC. Whenever the switch is pressed, the PCR gets alerted.

## **ADVANTAGES**

- (i) This ITCS/MPTS is durable, easy to use and handle.
- (ii) The ITCS/MPTS can also be used as a fire extinguisher in emergency situations.
- (iii) A laser installed in the ITCS/MPTS keeps track of the speed of the vehicles as well as those vehicles that jump the traffic signal.
- (iv) The ITCS/MPTS is provided with search light and a siren which would get activated under emergency situations.
- (v) The ITCS/MPTS can be used to notify any emergency situation around it to the PCR.

## **APPLICATIONS**

- (i) The traffic flow can be efficiently regulated and a lot of time can be saved.
- (ii) Loss of precious lives and destruction to property can be minimized to a greater extent.
- (iii) Unnecessary burden on the police personnel is greatly reduced.
- (iv) Better means of checking traffic violations without disturbing other travellers.
- (v) Offices, ATM's and houses can be more secure.

## **CONCLUSION**

The improvement of town traffic condition is largely dependent on the modern ways of traffic management and control. Advanced traffic signal controllers and control system contribute to the improvement of the traffic problem. It is observed that the proposed ITCS/MPTS is more efficient than the conventional controller in respect of efficient operation during emergency mode. Moreover, the designed system has simple design, fast response time, energy efficiency, durability, user friendliness, multipurpose functions and scope for further expansion. Being technologically advanced, it uses less man power.

## STEPS OF MATHEMATICAL MODELLING

**STUDENT**  
Benish Darik

Jawahar Navodaya Vidyalaya,  
Dhemaji, Assam

**TEACHER**  
Rabinder Nath Kakarya

### INTRODUCTION

This model is developed to make the community aware of the use of mathematical modelling for displaying in our daily life situations. Here the usefulness of mathematical modelling for displaying the advertisement sign boards across the highways or in shopping areas are discussed. Fig.1 shows the steps used that need to be taken while developing a mathematical model.

### STEPS OF MATHEMATICAL MODELLING

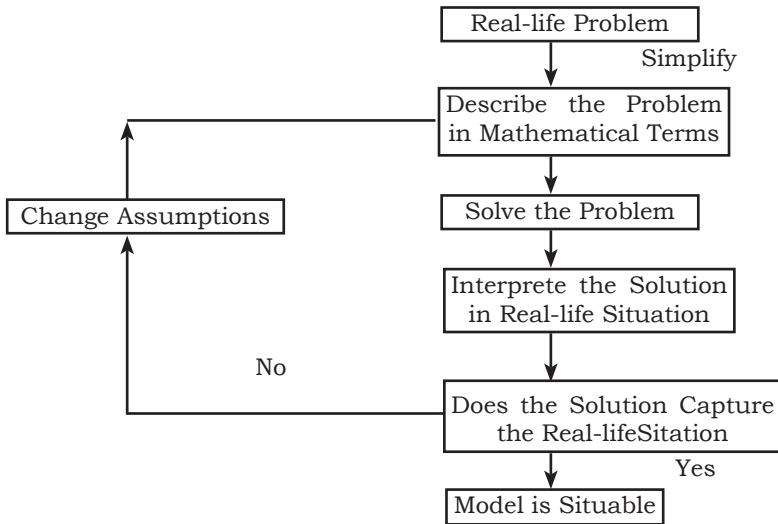
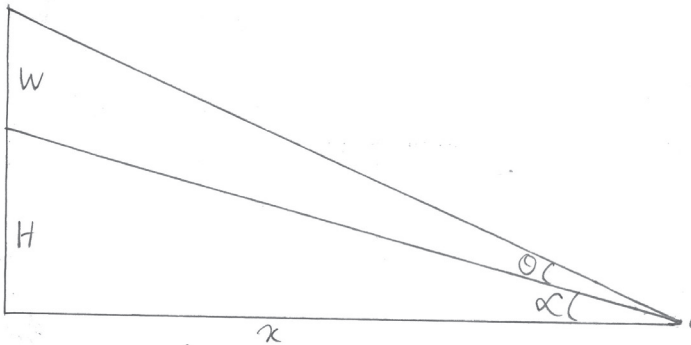

**Fig.1: Various Stages in Mathematical Modelling**

### SPECIFIC PROBLEM TAKEN

To place a sign board or advertisement board of given width and given height, at a distance which may be viewed vividly.

A specific board situation as explained in Fig. 2 is taken here.



**Fig.2: Observer View**

A board width 'W' = 15 ft, and its bottom at a height, H = 40 ft, above the ground level is placed at a distance x ft, from the observer in the ground level.

Let,  $\theta$  = viewing angle of the board, and  $\alpha$  = viewing angle of the 'H'.

Various experimentally determined observations are given in table 1, Fig. 3 and Fig. 4.

Experimentally, we find viewing angle ( $\theta$ ) of the board, by changing distance x.

For experiment, we take a board of width 15cm and height 40 cm. [it will not deviate our result as we are taking similar triangles, angle will not be affected].

**Table 1**

Distance, measured manually (in cm)	Viewing angle of the Board (in degree)
30	8.3
33	8.6
36	8.8
39	8.9
42	8
45	9.1
48	9.1
51	9.1

54	9
57	8.9
60	8.8
63	8.7

**OBSERVATION**

We observe that if the distance is far away from the board, the viewing angle is small and if we move nearer and nearer viewing angle increases and then decreases when we move very near to the board.

Graphically, we find as follows:

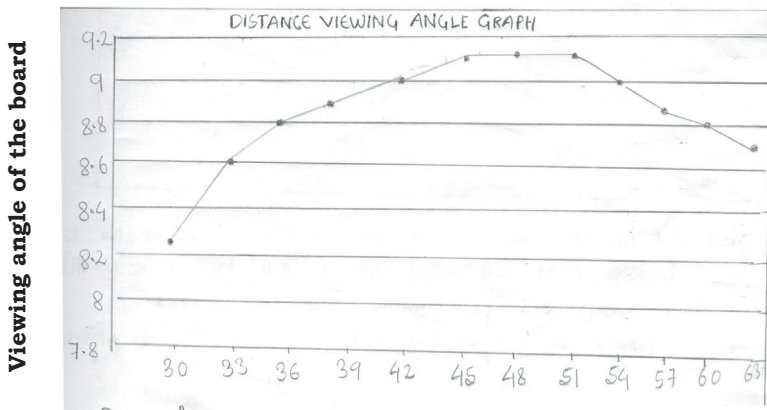

**Fig. 3: Distance of the foot of the board from observer Line Graph**

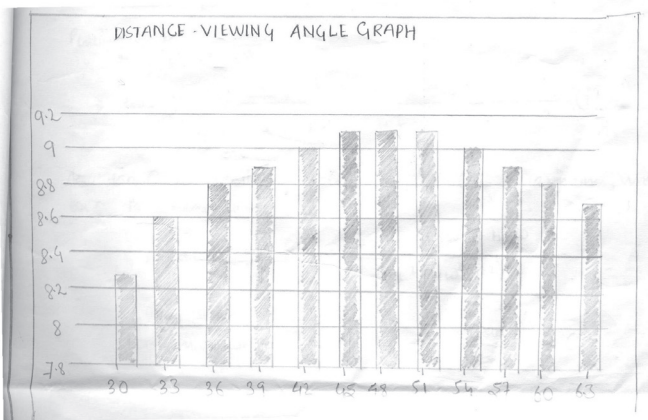

**Fig.4: Bar Graph**

## MATHEMATICAL FORMULATION OF THE PROBLEM

Let us consider Fig. 2 and 'w' be the width of the board. Let 'H' be the height of the bottom of the board from the level ground.

Let 'θ' be the viewing of the Board. Let 'α' be angle of elevation of the bottom of the board.

$$\tan \alpha = \frac{H}{x}$$

$$\text{and } \tan(\theta + \alpha) = \frac{W + H}{x}$$

$$\Rightarrow \frac{\tan \theta + \tan \alpha}{1 - \tan \theta \tan \alpha} = \frac{W + H}{x}$$

$$\text{Putting, } \tan \alpha = \frac{H}{x}$$

$$\tan \theta = \frac{Wx}{x^2 + HW + H^2}$$

As  $\tan \theta$  is positive in  $0^\circ$  to  $90^\circ$ ,  $\theta$  is maximum, when  $\tan \theta$  is maximum.

$$\text{Now, } \frac{d(\tan \theta)}{dx} = \frac{x^2 w + Hw^2 + H^2 w}{x^2 + HW + H^2}$$

$$\text{for maximum value of } \tan \theta, \quad \frac{d(\tan \theta)}{dx} = 0$$

$$\text{which implies 'x' = } \sqrt{HW + H^2}$$

$$\text{Again, } \left( \frac{d^2(\tan \theta)}{dx^2} \right) \text{ at } x = \sqrt{HW + H^2} \text{ is } \frac{-2xW(x^2 + HW + H^2)}{(x^2 + HW + H^2)^4}$$

which is negative.

Hence,  $\tan\theta$  is maximum, when  $x = \sqrt{HW + H^2}$ , that is  $\theta$  is maximum when  $x = \sqrt{HW + H^2}$

**APPLICATION OF THE MATHEMATICAL SOLUTION TO OUR REAL-LIFE SITUATION**

In our experiment,  $w = 15$  ft. And  $H = 40$  ft., then the distance from which advertisement board can be viewed vividly is

$$\sqrt{40 \cdot 15 + 40^2} = 46.90 \text{ ft (approx)}$$

The results are given in Fig. 5 and 6. The validity of the attempt is also shown in the Figure.

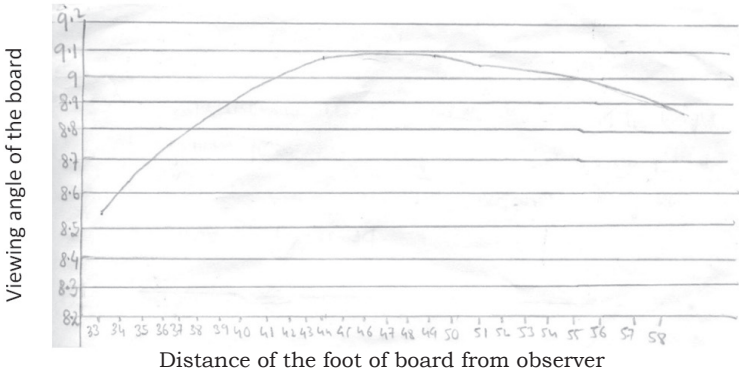

**Fig. 5: Line Graph**

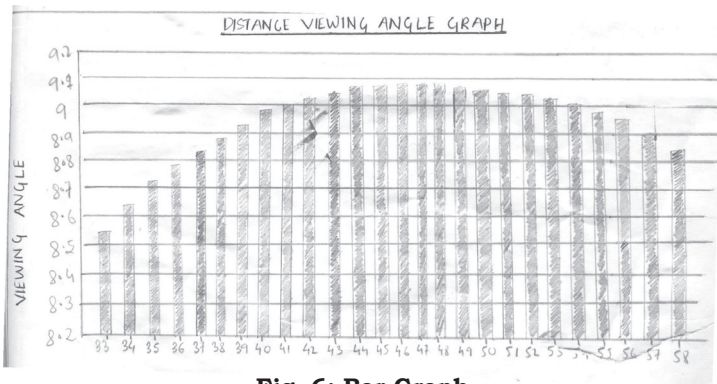

**Fig. 6: Bar Graph**

### VALIDITY OF THE MODEL

Mathematical solution obtained is matched with the experiment conducted, as maximum value is in the range 45 to 51cm. Further, let us compare the names obtained with the formula with the experiment.

H = 40, W= 15 (as it involve ratio unit of length is neglected)

**Table 2**

Measurements by using formula		
Distance	$\tan \theta = \frac{Wx}{x^2 + HW + H^2}$	Values of $\theta$ by using table
30	0.1452	8.2616
31	0.1471	8.3682
32	0.1489	8.4691
33	0.1505	8.5588
34	0.152	8.6428
35	0.1533	8.7156
36	0.1545	8.7828
37	0.1555	8.8387
38	0.1564	8.889
39	0.1572	8.9338
40	0.1579	8.9729
41	0.1585	9.0065
42	0.1589	9.0288
43	0.1593	9.0512
44	0.1596	9.0679
45	0.1598	9.0791
46	0.1599	9.0847
47	0.1599	9.0847
48	0.1599	9.0847
49	0.1597	9.0735
50	0.1596	9.0679
51	0.1593	9.0512
52	0.1591	9.04
53	0.1587	9.0176
54	0.1583	8.9953

The graph drawn from experimental value and the graph drawn with values of the formula have same optimal solution, thus our formula is valid for use.

### **CONCLUSION**

An advertisement board of width “w” and its height of bottom from the level ground “H”, must be placed at a distance

$\sqrt{HW + H^2}$  so, that it may be seen vividly by crowd.

## MULTIPURPOSE GEOTHERMAL PLANT

---

### STUDENTS

Pratheeksha Praveen  
Zayana Ali

Providence Higher School,  
Calicut, Nadakkavu, Kerala

### TEACHERS

Anitha Kumary C  
Sajima Beegam M.P

---

### INTRODUCTION

The topic Multipurpose Geothermal Plant that we have selected is very relevant in today's context. The reason behind the selection of this topic were some thoughts that have flashed through our mind. On a daily basis, we hear of burning issues and crises and one among them is the energy crisis which people are facing. Though India is said to be a developing country it is still lagging when it comes to conservation of energy. If this state continues it will not only affect the economic, commercial and social sector but also the scientific world. We agree that the major milestone in the history of science includes the discovery of electricity, which is the major source of energy and the same has helped man to explore the vast mysteries of science. For an upcoming young scientist, this energy crisis will surely be a gaping question in our future. This crisis is going to affect people from the lowest rung of the society to the highest. This clearly underline the fact that mankind will face catastrophe. So, we are initiating a small valuable suggestion to overcome this crisis through this exhibit which we believe will take a mighty step.

### SCIENTIFIC PRINCIPLE INVOLVED

Energy Conversion (mechanical energy to electrical energy);  
Electromagnetic induction;  $\Delta G = \Delta H - T\Delta S$ ; Adsorption; Electrolysis.

## MATERIAL REQUIRED

In order to represent this model we used simple PVC pipes, cardboard pieces, boxes, straw, papers, thermocol, thread, small plants, colors, pins, metal wires. By using these materials we construct a simple and an attractive model through which we have conveyed our idea effectively and clearly.

## CONSTRUCTION AND WORKING

The working of geothermal power plant is based on natural phenomenon. There is no usage of artificial chemicals/pollutants in this method. At first underground water gets heated directly through magma convection and then it is sent to a steam turbine, where the thermal energy is converted to electricity with a generator through a phenomenon called electromagnetic induction. The next step in the cycle is cooling the fluid and sending it back to the heat source.

Water that has been seeping into the underground over time has gained heat energy from the geothermal reservoirs. There is no need for additional heating as we would expect with other thermal power plants. Heating boilers are not present in geothermal power plants and no heating fuel is used. The whole process is carried out by using the natural heat produced inside the earth. In the beginning, production well are used to lead hot water or steam from the reservoirs into the power plant. Injection well

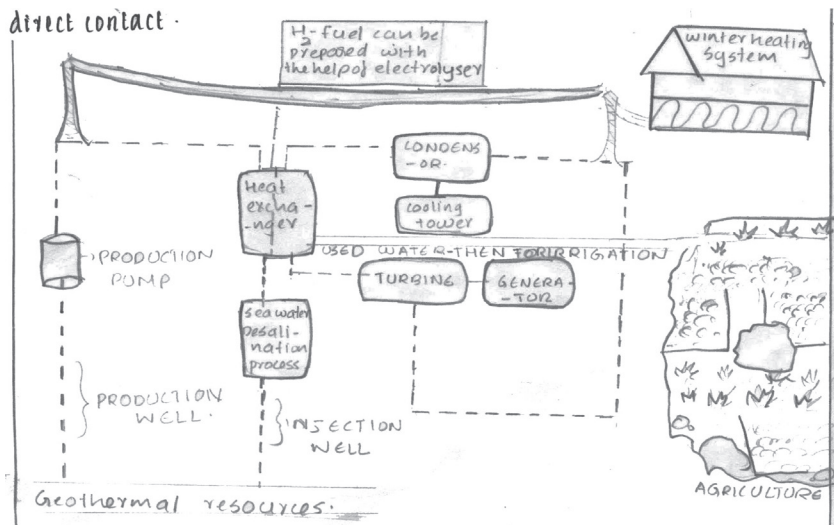

Fig. 1: Geothermal Plant

ensures that the water that is drawn up from the production well return to the geothermal reservoir, where it regains the thermal energy, that we have used to generate electricity. Condensers are used to effect condensation of steam and other condensable vapours by means of direct contact with condensing water. Here cooling lowers the heat and removal devices are used to transfer process waste heat to the atmosphere, through the cooling of a water stream to a lower temperature. Heat exchanger used here is a piece of equipment built for efficient heat transfer from one medium to another. The media is separated by a solid wall to prevent mixing and direct contact.

In the heat exchanger we can use isopropane/isobutene/  $\text{NH}_3$  water/water. Among this we prefer water due to its availability and it causes no pollution.

### **APPLICATIONS**

We agree that some geothermal power plants are existing in different parts of the world. But our idea and the model we have created is something entirely different from those. The geothermal power plant that we have created has multipurpose utilities. The wide applications of our geothermal power plant are listed below.

- (i) It can be used in industries, farms, heating and cooling purposes.
- (ii) The water that is stored in the heat exchanger can be sent to farms for agricultural purpose when it is replaced (replacement is necessary only in an interval of two-three years).
- (iii) Hydrogen fuel is considered to be the future fuel, which is a very efficient fuel. But hydrogen fuels are not widely produced or used in our country. So our geothermal plant provides a chance to obtain hydrogen from the thermal decomposition of water stored in gas exchanger, with the help of an electrolizer. This hydrogen can be obtained whenever necessary and transported according to our needs.
- (iv) Used in sea water desalination- Sea water desalination is the most promising field for the application of geothermal energy due to the coincidence of water scarcity, sea water availability and geothermal potential.

## **CONCLUSION**

There are states in our country which have potential for the development of geothermal power production process. But they are not aware about their own natural resources and other possibilities. We are very hopeful that through this exhibit, it can bring many changes in our society.

## AIR THERMOMETER

### STUDENT

Basharat Shafi Najar

Hanfia Model Higher  
Secondary School, Kreeri  
Zone, Wagoora, Baramulla,  
Jammu and Kashmir

### TEACHER

Fayaz Ahmad Wali

### INTRODUCTION

Usually, thermometers make use of expansion of a liquid (mercury or alcohol) to measure the temperature. But an air thermometer makes use of air expansion for temperature measurement. Due to the rise in temperature, the air expands by which a liquid is pushed down in a tube. The tube which is calibrated with the markings of temperature scales, indicates the temperature at a particular moment.

### SCIENTIFIC PRINCIPLE INVOLVED

The instrument works on the principle of Charles law, which states that at constant pressure, the volume of a given mass of a gas increases or decreases by  $1/273$  of its volume at  $0^\circ\text{C}$  for each one degree rise or fall in temperature. For one degree rise in temperature,

$$\text{Volume increase} = V_0 \times 1/273$$

For “t” degree rise in temperature

$$\text{Volume increase} = V_0 \times 1/273 \times t$$

$\therefore$  Volume at  $t^\circ\text{C}$

$$V_t = \text{Initial volume} + \text{Increase in volume}$$

$$= V_0 + V_0 \times t/273$$

$$\text{Or } V_t = V_0 [1+t/273]$$

Where  $V_0$  is volume of given mass of gas at  $0^\circ\text{C}$

Charles law may also be stated as:-

The volume of a given mass of a gas is directly proportional to the absolute temperature at constant pressure.

If  $V_1$  is volume of a certain mass at temperature  $T_1$  and  $V_2$  is

volume of the same mass of the same gas at temperature  $T_2$  at constant pressure, then according to Charles law,  $V_1/T_1 = V_2/T_2$ .

### **MATERIAL REQUIRED**

For preparing this exhibit we require one plastic sphere of known volume; one transparent glass tube of known diameter about 20-30 cm long; a suitable stand; one mercury thermometer and one small plastic half bottle to carry water.

### **CONSTRUCTION AND WORKING**

The transparent tube is fitted on one side with the plastic sphere through a hole and covered with a paste (m-seal) in order to make it air tight. The other side of tube is put into a jar or plastic half bottle which contain coloured water.

The plastic sphere is slightly warmed by rubbing with hands or some other source to make the air expand. Some air will bubble out through the water. One cooling, the water from the jar will rise into the glass tube. Now, we paste a white cardboard behind the glass tube and mark it at liquid level in glass tube.

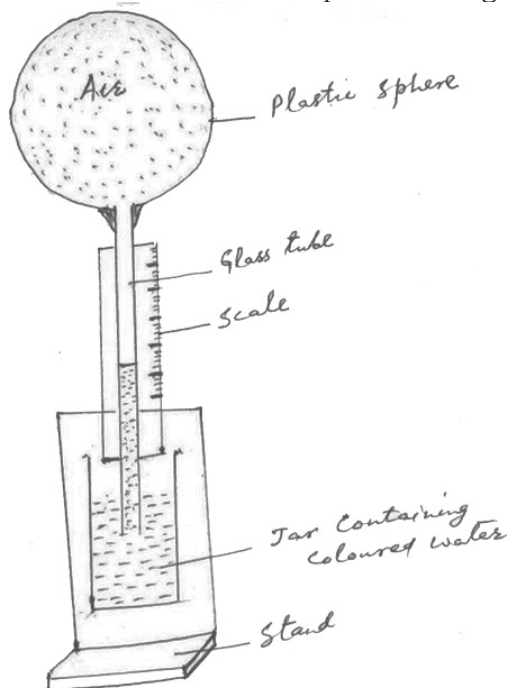

**Fig. 1: Air Thermometer Apparatus**

Note the temperature at the same place with the help of mercury thermometer.

Now put the air thermometer in a cold room and mark another line on the cardboard and also note temperature by mercury thermometer. Divide the space between the two markings in equal parts to prepare a scale.

### **MERITS AND ADVANTAGES**

- i. As the properties of gas remain unchanged over a wide range of temperature, a gas thermometer is more suitable than a liquid thermometer for a wide range.
- ii. As gases expand more than liquids, an air thermometer is more sensitive than liquid thermometer.
- iii. It is cheaper than liquid or mercury thermometer.
- iv. Mercury is a toxic metal and have chances of accidents.

### **APPLICATIONS**

- i. This model can be used to measure temperature at any place, in laboratories, at home, etc.
- ii. The model can be used to verify Charles law.

## बहुस्तरीय भट्टी

### विद्यार्थी

कृति श्रीवास्तव

आर्य महिला इण्टर कॉलेज  
चेतगंज, वाराणसी, उत्तर प्रदेश

### अध्यापक

शिल्पी साहू

### प्रस्तावना

हमारे दैनिक कार्यों को पूरा करने के लिए हम जिस शक्ति का उपयोग करते हैं वही ऊर्जा है। हमने देखा है कि ग्रामीण लोग भट्टी पर एक समय में केवल एक ही भोजन पका सकते हैं जिससे समय तथा ऊर्जा दोनों की ही एक बड़ी मात्रा नष्ट हो जाती है।

इसी ऊर्जा का उपयोग करने के लिए हमने एक नयी प्रकार की भट्टी बनायी है जिसमें हम उतने ही कोयले में एक साथ एक से अधिक कार्य कर सकते हैं।

इस प्रकार इस भट्टी का प्रयोग गरीब लोग भी आसानी से एवं कम लागत में कर पायेंगे। इससे उनके धन और समय के साथ ही साथ ऊर्जा की भी बचत होगी।



चित्र 1

## परियोजना शीर्षक चुनने का कारण

कुछ गाँवों में सर्वेक्षण करने के पश्चात हमें यह ज्ञात हुआ कि गाँव में लोग कोयला अधिक महँगा हो जाने के कारण इसे अधिक मात्रा में खरीदने में सक्षम नहीं होते हैं जिस कारण उन्हें काफी परेशानियों का सामना करना पड़ता है। हमारी इस परियोजना शीर्षक चुनने का कारण भी यही है कि हम इन परेशानियों को दूर कर सकें।

इसलिए हमने एक नयी प्रकार की भट्टी का मॉडल तैयार किया है जिसमें हम एक साथ उतने ही कोयले में एक से अधिक काम कर सकते हैं। इस प्रकार ग्रामीण लोगों की परेशानियों को दूर करने के साथ ही हम समय तथा ऊर्जा की एक बड़ी मात्रा को व्यर्थ होने से बचाने का प्रयास कर सकते हैं।

इस भट्टी को बनाने में लागत भी बहुत कम लगती है।

## सर्वेक्षण

सर्वप्रथम हम लोगों ने इस विषय को चुनने के बाद अपने क्षेत्र के गाँव में जाकर सर्वेक्षण किया कि किन लोगों के पास भट्टी है और किन लोगों के पास नहीं है। यदि है तो चल रही है या बन्द है। यदि बन्द है तो क्यों? इन सभी बातों का सर्वेक्षण करके हमें यह पता चला कि जो भट्टी बन्द थी उनके निम्न कारण हैं-

1. एल.पी.जी. चूल्हा उपलब्ध होने के कारण।
2. कभी-कभी मिट्टी की भट्टी टूट जाती है, तो उसे बार-बार जोड़ना पड़ता है।
3. भट्टी के कारण घर में धुँआ हो जाता है।
4. भट्टी में भोजन पकाने में अधिक समय लगता है।

## उद्देश्य

प्रयोग से संशोधित भट्टी द्वारा कोयले की खपत को कम करना तथा लोगों को जागरूक करना।

## सामग्री

पुरानी भट्टी, मिट्टी, लोहे की छीलन,  $MgO_2$  लोहे की प्लेट, सिरैमिक, कोयला, इत्यादि।

## वैज्ञानिक सिद्धांत

इस मॉडल का प्रयोग करने से भट्टी के नीचे की तरफ की उष्मा व्यर्थ नहीं जाती तथा इसका उपयोग करने से भोजन पकाने के साथ ही साथ हम पानी इत्यादि भी गर्म कर सकते हैं।

## संरचना

सर्वप्रथम हमने पुरानी भट्टी में ही कुछ संशोधन करके एक नए प्रकार की भट्टी बनायी जिसमें लोहे की छड़ के स्थान पर लोहे की प्लेट लगायी तथा इसमें तीन स्तर हैं। सबसे निचले स्तर में दो से ढाई लीटर के डिब्बे में पानी गर्म कर सकते है। मध्य स्तर में हम भोजन को गर्म कर सकते हैं तथा सब्जियों को भून सकते हैं। प्रथम स्तर पर सामान्य प्रकार से भोजन पका सकते हैं।

इसमें अन्दर की ओर एक परत सिरैमिक की लगायी जो कि उष्मा का सुचालक है जिससे भट्टी का ताप अधिक समय तक बना रहता है। इसके पश्चात मिट्टी, गोबर एवं भूसी के मिश्रण की दूसरी परत लगायी। भट्टी के बाहर की ओर मिट्टी, गोबर, भूसी एवं लोहे के छीलन के मिश्रण की मोटी परत लगायी।

## परीक्षण

प्रयोग के द्वारा हमने पाया कि पुरानी भट्टी में एक किलो कोयले के प्रयोग से हम चार लोगों का खाना बना सकते हैं, जबकि संशोधित भट्टी में उतने ही कोयले के प्रयोग से हम सात लोगों का खाना बना सकते हैं।

## पुरानी भट्टी तथा संशोधित भट्टी की दक्षता में तुलना

क्रम संख्या	ईंधन की मात्रा	पुरानी भट्टी में प्रति घण्टे तैयार भोजन (सदस्य की संख्या)	संशोधित भट्टी में प्रति घण्टा (सदस्य की संख्या)
1.	1 किग्रा.	4	7
2.	2 किग्रा.	6	10
3.	3 किग्रा.	9	12

## निष्कर्ष

इस मॉडल का प्रयोग करने से भट्टी के नीचे की तरफ की उष्मा व्यर्थ नहीं जाती तथा इसका उपयोग भोजन पकाने में होता है। इससे कोयले एवं समय की बचत होती है।

## सामाजिक प्रभाव

यह एक आसान और सुलभ मार्ग है जो ऊर्जा की अधिक खपत को कुछ कम कर सकता है। इसके उपयोग से सबसे बड़ा फायदा यह है कि इसमें एक साथ एक से

अधिक कार्य हो सकता है। इसमें उपले और लकड़ी के उपयोग के कारण यह गरीब वर्ग के लोगों के लिए वरदान सिद्ध हो रही है। इस मॉडल के प्रयोग से समाज पर कोई बुरा प्रभाव नहीं पड़ रहा है।

### **उपयोग**

1. इससे समय की बचत होती है।
2. इससे कोयले की बचत होती है।
3. सबसे महत्वपूर्ण बात यह है कि इस मॉडल का उपयोग करके हम उर्जा की एक बड़ी मात्रा को व्यर्थ होने से बचा पाते हैं।
4. इस मॉडल का प्रयोग गरीब वर्ग के लोग भी आसानी से कर सकते हैं क्योंकि इसको बनाने में लागत कम लगती है।

**विद्यार्थी**

निशान्त गौड़

बेसिक पब्लिक स्कूल,  
सरदारशहर, राजस्थान**अध्यापक**

बजरंगलाल सोनी

**भूमिका**

मानव हमेशा से ही अपने ज्ञान के विकास के साथ-साथ नित नये वैज्ञानिक सिद्धान्तों की खोज करता रहता है तथा इन सिद्धान्तों पर आधारित आविष्कार करता रहता है। पहिये का आविष्कार, जीन थ्योरी, पेन्सिलीन का आविष्कार, तथा गुरुत्वाकर्षण सिद्धान्त, सापेक्षतावाद, प्रकाश विद्युत प्रभाव आदि इन्हीं आविष्कारों में से एक है क्रेन का आविष्कार। इस आविष्कार ने विज्ञान के अन्य आविष्कारों के लिए आधार का कार्य किया है। एक सरल उत्तोलक से विकसित होती हुई क्रेन अब विभिन्न प्रकार के कार्यों को करने में सक्षम हो गई है। ऐसे बहुत से काम जो मनुष्य अपने हाथों से आसानी से नहीं कर सकता था उन कार्यों में भी इसने बहुत सहायता की है। इस प्रदर्श में एक संवधिति क्रेन को दर्शाया गया है जिसकी सहायता से विभिन्न प्रकार के कार्यों में सुविधा हो सकती है।

**वैज्ञानिक सिद्धान्त:** इस प्रदर्श को बनाने में कई वैज्ञानिक सिद्धान्तों का उपयोग किया गया है-

1. सरल उत्तोलक का सिद्धान्त;
2. चुम्बक के आकर्षण व प्रतिकर्षण का सिद्धान्त;
3. विद्युत चुम्बकीय प्रेरण का सिद्धान्त; और
4. सेमीकन्डक्टर इलेक्ट्रॉनिक्स व इलेक्ट्रीसिटी के सामान्य सिद्धान्त।

## आवश्यक सामग्री

एल्युमीनियम, लकड़ी, प्लाई, रबड़, धातु की चादर, विद्युत मोटर, प्रतिरोध, संधारित्र, आई.सी., एल.ई.डी., स्विच, ट्रांसफार्मर आदि। इसके साथ-साथ वीडियो कैमरा तथा टी.वी. का भी उपयोग किया गया है।

## कार्य प्रणाली

इस प्रदर्श में क्रेन माडल के साथ इलैक्ट्रॉनिक परिपथों का संयोजन किया गया है तथा दृश्य के लिए एक सी.सी.डी. कैमरा और टी.वी. को भी व्यवस्थित किया गया है। इसको चलाने हेतु विशेष रूप से विद्युत मोटर तथा खराब टेबल घड़ी से बनाया गया गियर बाक्स लगाया गया है। प्रत्येक दिशा में मूवमेंट के लिए एक मोटर तथा गियर बाक्स का प्रयोग किया गया है। प्रत्येक मोटर अलग-अलग स्विचों से नियंत्रित होती है।

मोटर को फारवर्ड तथा रिवर्स चलाने के लिए टागेल स्विचों का प्रयोग किया गया है जिससे डी.सी. विद्युत धारा की दिशा बदली जाती है। इसकी भुजा को भी ऊपर-नीचे, दाएँ-बाएँ व आगे-पीछे इन्हीं स्विचों द्वारा किया जाता है। विशेष परिस्थितियों में (जैसे विस्फोटक पदार्थों को उठाना आदि) में इसे रिमोट द्वारा भी संचालित किया जा सकता है तथा रिमोट द्वारा संचालन में क्षेत्र के सही ज्ञान के लिए कैमरे का भी प्रयोग किया गया है।

## उपयोग

1. साधारण परिस्थितियों में इसे एक सुयोग्य क्रेन के रूप में उपयोग किया जा सकता है। इसका उपयोग कृषि, उद्योग, भवन निर्माण, दैनिक कार्यों में सामान को हटाने व अन्यत्र ले जाने आदि के लिए भी किया जा सकता है।
2. इसमें इलैक्ट्रॉनिक परिपथ का समावेश होने के कारण इस उपकरण का उपयोग बारूदी सुरंगों को हटाने के लिए किया जा सकता है।
3. जटिल, जहरीली रासायनिक अभिक्रियाओं के पदार्थों को मिलाने तथा उनको नियंत्रित करने के उद्देश्य से भी इसका उपयोग किया जा सकता है।
4. विशेष प्रकार के उद्योगों में जहाँ हाथ अथवा हाथ से नियंत्रित औजारों का उपयोग करना निषेध हो, ऐसे स्थानों पर इसका उपयोग किया जा सकता है।
5. कई परिस्थितियों में यह एक सुपर क्रेन की तरह कार्य कर सकता है।

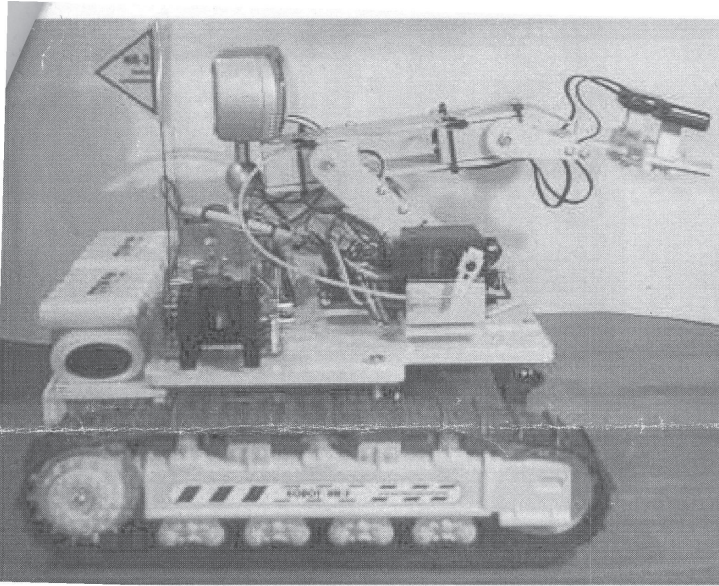

चित्र - 1

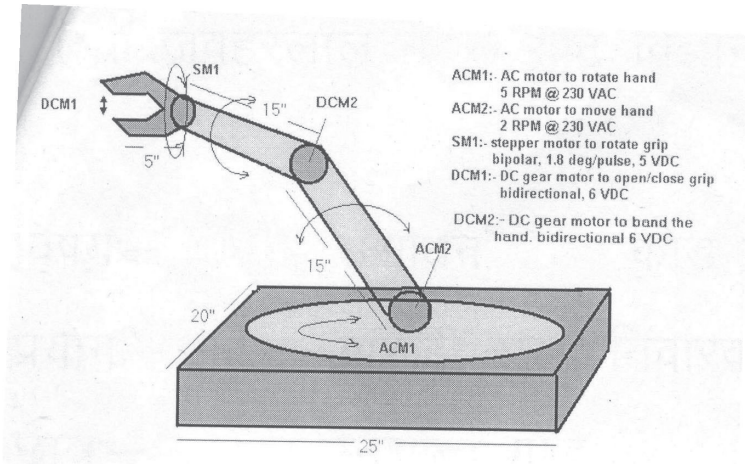

चित्र - 2

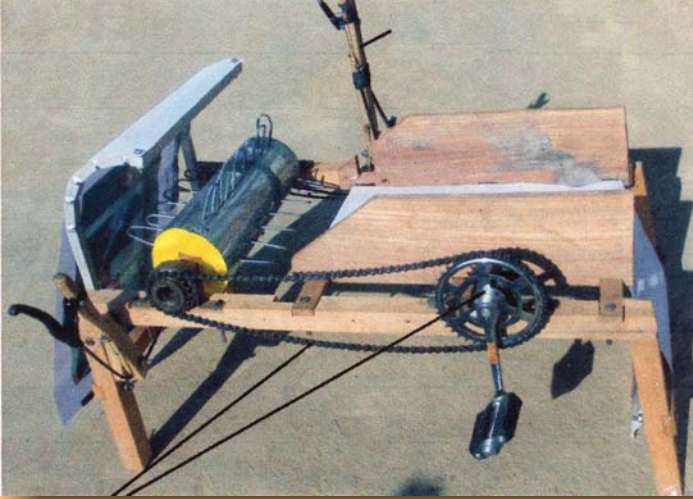

विद्यया ऽ मृतमश्नुते



एन सी ई आर टी  
NCERT

राष्ट्रीय शैक्षिक अनुसंधान और प्रशिक्षण परिषद्  
NATIONAL COUNCIL OF EDUCATIONAL RESEARCH AND TRAINING