

Structure and Working of Science Models



36TH JAWAHARLAL NEHRU
NATIONAL SCIENCE EXHIBITION
FOR CHILDREN

Kolkata, West Bengal

विद्यया ऽ मृतमश्नुते



एन सी ई आर टी
NCERT

2009

Structure and Working of Science Models 2009



राष्ट्रीय शैक्षिक अनुसंधान और प्रशिक्षण परिषद्
NATIONAL COUNCIL OF EDUCATIONAL RESEARCH AND TRAINING

November 2009
Agrahayana 1931

PD 5T RNB

© National Council of Educational Research and Training 2009

Publication Team

Editorial : R. N. Bhardwaj

Production : Atul Saxena

Cover : D. K. Shende

Published at the Publication Department by the Secretary,
National Council of Educational Research and Training,
Sri Aurobindo Marg, New Delhi 110 016 and printed at :

.....

PREFACE

The learning of Science is instrumental in developing well defined abilities and skills such as spirit of enquiry, creativity, objectivity and aesthetic sensibilities in young minds. Experiments are the hallmarks of science and its learning, they are essential. Rigid and theoretical lessons of the formal system, and often inadequate demonstrations and experiments do not provide opportunity to the naturally curious children to indulge in the joy of scientific investigation. Science Exhibitions offer an opportunity to the students to express and exchange their creative ideas, help them to learn the methods of science, provide them with opportunity to develop their problem solving skills and creative abilities.

With these aims, the National Council of Educational Research and Training (NCERT) organises the Jawaharlal Nehru National Science Exhibition for Children (JNNSEC) as an annual event in collaboration with a State or Union Territory on rotation basis. The JNNSEC is the final activity of a series of exhibitions organised at zonal, district, regional and state levels and a large number of students and teachers participate in such events.

The present publication includes write-ups of a few exhibits selected for display in the 36th JNNSEC being organised in Kolkata, West Bengal. Other materials like List of Exhibits which contains the titles and synopsis of almost all the exhibits selected for JNNSEC – 2009 along with Folder stating objectives and other details of exhibition have also been published. It is expected that these publications will motivate and help children to participate in future Science Exhibitions.

The write-ups included in this publication were selected and edited by Professor B.K. Tripathi, Dr V.P. Singh, Dr Gagan Gupta, Dr Alka Mehrotra, Shri R. Joshi, Dr Shashi Prabha, Dr Anjani Koul, Dr P. K. Chaurasia and Ms Sunita Varte of the Department of Education in Science and Mathematics (DESM) of NCERT, I appreciate their sincere efforts. I thank Dr Dinesh Kumar also who started the work of the exhibition this year.

I specially thank Professor B. K. Tripathi for Coordinating the 36th JNNSEC–2009 and seeing this manuscript through the press. I also thank the Publication Department, NCERT for the cooperation in bringing out this publication and for the excellent production quality.

New Delhi
20 October 2009

HUKUM SINGH
Professor and Head
DESM
National Council of Educational
Research and Training

CONTENTS

PREFACE	iii
1. Floating Houses for Flood Affected Areas	1
2. Simple and Low Cost Solar Water Heater	5
3. Eco-friendly Cost Effective Thermo Electricity at the Blast Furnace Site of Steel Plants	8
4. Measuring Wind Speed	12
5. Fun Games	17
6. Indigenous Incubator	22
7. Geothermal Desalinator	25
8. Eatable Spoons Eco-friends	27
9. Energy Production from Heat of Sunlight Falling on the Roof of the Building	30
10. Safety Alarm for LPG Leakage	34
11. Useful Products from Fishery Waste	37
12. Self-sufficient House	41
13. Innovative Fire Intercepting Device	45
14. Multiutility Bioproduct System	48
15. Global Warming and Climate Change	53
16. भीड़भाड़ के क्षेत्र में भगदड़ पर नियंत्रण	56
17. उत्तराखंड की दुर्लभ जड़ी-बूटियाँ	59
18. कोयला खनन क्षेत्रों की भूमिगत आग से विद्युत ऊर्जा	64

19. बहुउद्देशीय अनलोडिंग वाहन सिस्टम	68
20. स्वदेशी कीटनाशक स्प्रेयर एवं खरपतवार नियंत्रक यंत्र	71
21. जल द्वारा चालित कार	74

FLOATING HOUSES FOR FLOOD AFFECTED AREAS

STUDENTS

Mahesh Vilas Patil

Hutatma Kisan Ahir Vidyalaya
Walwa, Sangli
Maharashtra**TEACHER**Shashikant Shankar Ambi

INTRODUCTION

A review of past few years climate shows that, living beings had to suffer the intense effects of changes in the climate because of Global Warming. Natural disaster and calamities have created havoc at all levels. The most dangerous is flood situation caused by melting of icebergs or the release of dam water for the safety of dams from heavy rainfall.

Due to frequent floods many lives ruin and wealth is lost, also the government has to bear a heavy economic load. Considering all this, we are going to introduce this project for the first time before you. Floating houses for flood affected areas.

OBJECTIVES

To highlight the seriousness of the problem and suggest solutions to avoid any damage in such situations.

SCIENTIFIC PRINCIPLE INVOLVED**Archimedes Principle**

A body immersed in water or any other fluid will displace a volume of water or fluid equal in weight to the immersed body.

MATERIAL REQUIRED

Angle box, digital boards, hard boards, rigid pillar, submersible motor, P.V.C. pipe, dripping tap, rubber tube etc.

CONSTRUCTION

While constructing floating houses, firstly, four rigid cylindrical iron pillars are erected in concrete foundation onto the land.

On these four rigid pillars, four hollow pillars are fixed with the minimum gap in between and with the support of these four hollow pillars, as shown in Figs. 1.1–1.3 the base of the floating house which is separated from land is made like a flat small boat.

The house is constructed on the base with hollow and light-weight concrete blocks so that the weight of the house is less.



Fig. : 1.1

WORKING

When the flood water will surround the house due to specificity of house it will slowly float on water according to the Archimedes principle and because of the vertical transitional motion on specific double layered pillars the house will be lifted only upwards. It will not move here and there as rigid pillars will hold it in position. When the flood water will decrease the house will come to the original position.



Fig. : 1.2

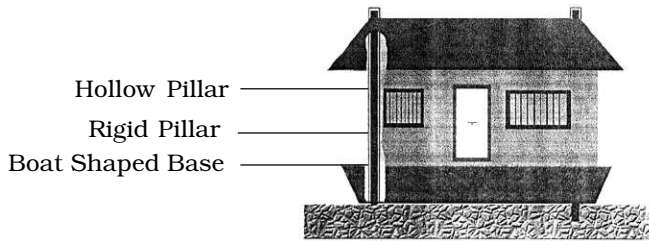

Situation before Flood

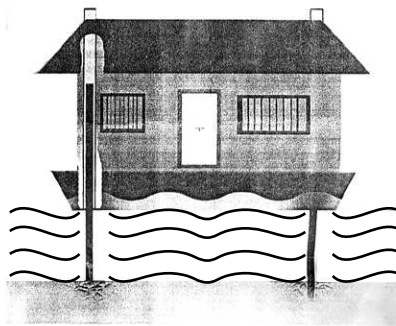

Situation during Flood

Fig. : 1.3

ADVANTAGES

- (i) Damage to life will be avoided.
- (ii) Migration of human beings and animals will be avoided.
- (iii) Damage of wealth will be avoided.
- (iv) We can install solar power system on the roofs of such types of houses for continuous electric supply.
- (v) The economic load on the Government will be less.
- (vi) Because of rigid pillars and a gap between the plinth and ground such types of houses will be protected from earthquakes also.

CONCLUSION

In this way the project 'Floating Houses for Flood Affected Areas' will be helpful for effective management of the disaster caused by flood.

SIMPLE AND LOW COST SOLAR WATER HEATER

STUDENTS

Suhail Ashraf
Girish Thapa

Kendriya Vidyalaya
Birpur Cantt, Dehradun
Uttarakhand

TEACHER

Usha Mendiratta
Charu Sharma

INTRODUCTION

Use of solar energy for heating water is environment friendly and very economical. The commonly used solar water heater is effective when it faces the sun. The present solar water heater is so designed that it keeps facing the sun and hence it is more efficient.

OBJECTIVES

Conservation and Utilisation of Natural Resources.

MODEL

Simple and low cost solar water heater and hot water container for low income group.

SCIENTIFIC PRINCIPLE INVOLVED

Black coloured copper container is a good absorber of heat. It can efficiently get heated by solar energy.

CONSTRUCTION

It consists of five units (Fig. 2.1) which are mentioned here:

Unit I: Black coloured metallic container of copper is filled with water. A transparent glass is placed on it so that the inside temperature can be increased. The whole unit is placed over a high stand in the sunlight.

Unit II: A cycle rim is fixed on an iron stand and a transparent plastic is tied on it in such a way that it can be filled with clean water, so that when it is placed in the sunlight it can act like a converging lens.

Unit III: Two metallic boxes are used. One is smaller and other is larger. Smaller one is placed inside the bigger one and in between the gaps of two boxes thermocol is filled so that their position is fixed. A hollow black coloured copper tube in the shape of coil is fixed inside the metallic boxes in such a way that its one end comes out from one side of the box and the other end comes out from the other side of the box.

Unit IV: An ordinary earthen pot is made a heat insulator by pasting a layer of the mixture of mud, wood powder, crushed paper and some dry grass on its outer surface.

Unit V: The box is made to move from east to west along with the change in the direction of sun, with the help of a mechanical structure and the wheels attached to it.

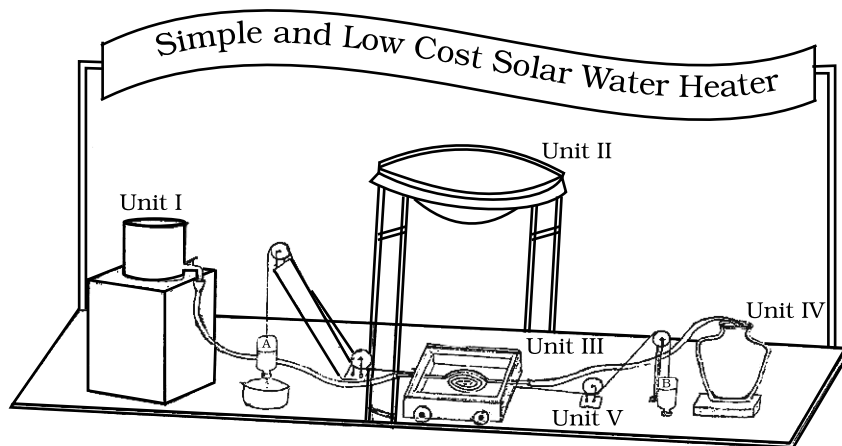

Fig. : 2.1

WORKING

In Unit I metallic container absorbs solar energy from the sun, the important role is played by its glass cover. It does not allow the infrared rays to go outside from it once they enter inside the container. It increases the inside temperature due to which the water gets heated. Unit II acts like a converging lens. It converges the sun rays on the metallic box of the Unit III.

Units I, III and IV are connected to each other by a hollow pipe. Water of the Unit I is allowed to flow slowly in the coil of metallic box through the hollow pipe. Water inside the coil gets heated up to 80–100 C. This hot water is collected inside the insulated earthen pot. We can keep this water hot up to 40–50 C till next morning.

To keep the box facing the sun a mechanical set up has been made using two identical bottles, thread and four pulleys. The bottles are filled with same amount of water. A bottle with a hole in it is placed in the east side of the sun. It loses water drop by drop. But as bottle B has no hole in it, it does not lose its water and becomes heavier than A. Bottle B is placed in the west direction so it keeps pulling the bottle A towards the west. In this way the metallic box slowly moves towards west.

APPLICATION

It can be used to heat water from the solar energy at very low cost.

ADVANTAGES

- (i) This model is environment friendly.
- (ii) It is very economic.

ECO-FRIENDLY COST EFFECTIVE THERMO ELECTRICITY AT THE BLAST FURNACE SITE OF STEEL PLANTS

STUDENTS

Ashish Bhoi
Anurag Sahoo

D.M. School
R.I.E., Bhubaneswar

TEACHER

J.P. Prahara

INTRODUCTION

In the twenty-first century thrust is mostly on electrical energy which has affected every sphere of life beginning with household applications to mega industries, from simple lighting solutions to intensive sophisticated health solutions. But when it comes to the production of electricity, except hydro-electricity, the other two major sources, viz, Coal/Naptha based thermo-electricity and Nuclear powered electricity production have environmental consequences although these are economical. Besides not being environment friendly the Coal/Naptha based and Nuclear powered electricity units also face the problem of raw material shortage and cause health-hazards. Rehabilitation, land resource crunch and waste-disposal add to the problem in many ways. Many innovative attempts have been going on and will continue to go on along with the present one to solve the problem.

RATIONAL BEHIND CONSTRUCTIONS OF THE EXHIBIT

This project is an attempt to solve the eco-hazards of coal based or nuclear energy based electricity units. Even if solely it may not suffice the required output, integrated efforts can provide or fulfil required level of output of the electricity.

SCIENTIFIC PRINCIPLE INVOLVED

Every electricity producing unit has the same basic principle of production of electricity, where blades of turbine rotate, which lead to the rotation of shaft connected to insulated turns of conducting coils in a magnetic field. This causes an induced Voltage/Current output. In addition, the present exhibit is based on the following principles.

Circulating Water Channel System

Extremely high heat conducting material pipes are set around blast furnace. Water is allowed to circulate through these pipes.

Compressed Steam Chamber

Water circulated in a channel system is converted to steam which is compressed in a steam chamber unit where it rotates the blades of turbine connected to generating unit.

Turbine and Power Generating Unit

Rotating turbine runs the generating unit and produces electrical energy.

Condensation and Re-circulating Unit

The steam utilised for running turbine is condensed in the condensation unit by circulating ice-cold water or some other appropriate technique. The condensed steam is re-used for circulation in water chamber unit, producing steam again to generate power.

MATERIALS REQUIRED

Pipes of high heat conducting material which can tolerate high temperature condition near blast furnace, dynamo, blades of turbine, shaft, turns of coil, and electric bulb.

CONSTRUCTION AND WORKING

The construction of present working model is shown in Fig. 3.1. It consists of the following major components:

- (i) Pipes for circulation of water
- (ii) Compressed steam chamber

- (iii) Turbine
- (iv) Dynamo
- (v) Condensation Chamber

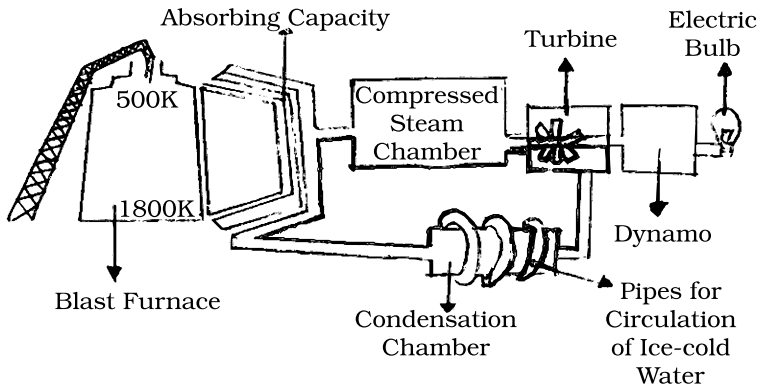

Fig. : 3.1

Water is circulated in the pipes set around furnace and capable of bearing a very high temperature. It absorbs the heat produced by the blast furnace. At the high temperature of pipes the water circulating in them gets converted to steam which moves to the steam compression chamber. Here the steam gets highly compressed and moves to the turbine chamber. The compressed steam that move through the outlet of steam chamber reaches the turbine and rotates the blades of the turbine ultimately rotating turns of coil of dynamo with a very high speed. With the rotation of the coil electricity is produced and the bulb starts glowing. The steam that is used to rotate the turbine moves to the condensation chamber where ice-cold water is circulated around it. Here the steam gets condensed and converted to water. The water again returns to the pipes where circulation and vaporisation of water takes place.

APPLICATIONS

- (i) The present model ensures the reduction in the use of coal and other sources of energy.
- (ii) By the reduction in the consumption of coal, its reserves will last for a longer time in earth and will give service to mankind for a longer time.
- (iii) This will also reduce the loss of the huge heat energy produced by the blast furnace to some extent.
- (iv) This will save a huge amount of money which the steel units spend for purchasing power.



MEASURING WIND SPEED

STUDENTS

D. Daniel Nitin

Atomic Energy Central School-2

Sadras, DAE Township

Kalpakkam

TEACHER

S. G. Lakshmi

INTRODUCTION

The energy needs of mankind have multiplied in the past years. In this scenario, with the dwindling conventional energy reserves the focus of the world is turning towards non-conventional sources of energy. Wind energy is one of the options. Blowing of wind is caused by an uneven heating of the earth's surface. It can be used to rotate the rotors of windmills and hence it can be used for generating electricity. For producing electricity a minimum wind speed of 13 km per hour is required. An anemometer is a device used for measuring wind speeds. This project involves the construction of two different types of anemometers working on simple principles of physics: a ping pong ball anemometer; and a rotating vane anemometer.

SCIENTIFIC PRINCIPLES INVOLVED

PING PONG BALL ANEMOMETER

Working Principle

This device works on the principle of conservation of energy. A schematic device is shown in Fig. 4.1. When wind blows in the direction shown in Fig. 4.1, it exerts a force on the ping pong ball and sets the ball into motion. Therefore, the ball gains kinetic energy.



Fig. : 4.1

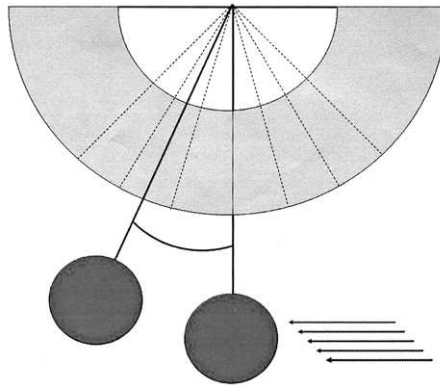

Fig. : 4.2

The ball starts swinging up to a height where all the kinetic energy is converted into potential energy. The angle θ (see Fig. 4.2) i.e., the angle between initial position of the ball and final position of the ball can be related to the speed of the wind as

$$V = \left(\frac{mg \tan \theta}{\rho A} \right)^{1/2}$$

Where V is the velocity of the wind in m/s;
 m is the mass of the ball in kg;
 g is the acceleration due to gravity;
 ρ is the density of air in kg/m^3 and
 A is the circular cross sectional area of the ball in m^2 .

Merits and Demerits

This is a very simple method to obtain approximate estimation of wind speed. This can be constructed from materials which are easily available at our homes. But this device can measure only approximate values of wind speed as it is difficult to measure the angle precisely.



Fig. : 4.3

ROTATING VANE ANEMOMETER

In order to obtain better estimates of the wind speed a different type of anemometer was constructed as shown in Fig. 4.4.



Fig. : 4.4

Working Principle

This device works on the principle of an electrical generator, where the mechanical energy is converted into electrical energy. If a coil is placed in a magnetic field, on rotation of the coil a voltage is developed which is proportional to the strength of the magnetic field, length of the coil, and the speed of the rotation. Therefore the greater the speed of rotation greater is the voltage generated. Fig. 4.5 shows the schematic device. The shaft of a 12 volts motor is attached to 3 vanes. When there is a wind flow, it rotates the vanes which in turn rotate the shaft thus generating a voltage in the terminals of the motor.

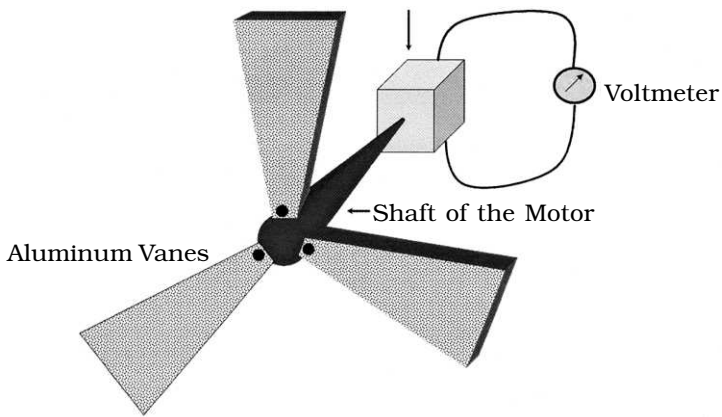

Fig. : 4.5

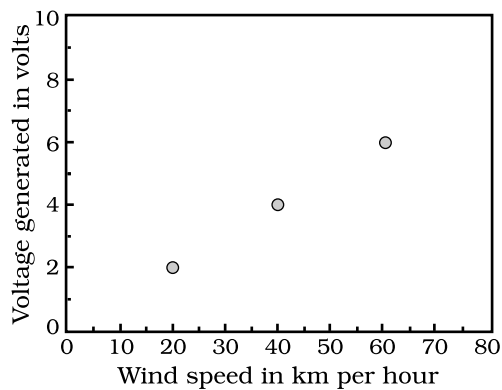

Fig. : 4.6

An Experiment for Calibration of the Device

An experiment was carried out for the calibration of this device. I traveled in a car with the device on a windless day. When the car was moving at a uniform speed of 20 km per hour, I held the device so that the wind in the opposite direction of the car could rotate the vane. I made measurements of the voltage. Similarly I measured voltages when the car was traveling at 40 km per hour and 60 km per hour. I constructed a graph between the car speed which is nearly the speed of the wind and the voltage generated at that particular speed. I have estimated the wind speed from the fan of a air conditioner to be about 1.67 volts and it corresponds to 16.7 km per hour.

5

FUN GAMES

STUDENT

Honey Singh
Rishab Jain

Government High School-19
Chandigarh

TEACHERS

Nidhi Gupta
Sweety Rani

INTRODUCTION

Good and effective teaching involves developing the art of teaching so nicely that the process of learning becomes an enjoyable experience for the teacher as well as the students. The present model is an effort to make the learning of mathematical concepts a joyous experience.

SCIENTIFIC PRINCIPLE INVOLVED

To create interest of students in maths and to correlate with every day life.

MATERIALS REQUIRED

Cardboard, thermocol sheets, chart paper, colours, matchsticks, glue, cellotapes.

WORKING

There are 5 games included in this project.

The First Game

The first game is *magic calendar* (Fig. 5.1). This magical calendar tells about the day of any particular date from 1951–2050. It shows the importance of mathematics in astrology also.

The Second Game

The second game is again a sort of *magic in any common calendar* (Fig. 5.2). It has 2 subparts. If at first we choose any 3x3 square in any month then the sum will always be 3 times the number at the centre. Second if we want to find the total of all the numbers in that square, mathematics gives a quicker and magical method. We just have to add 8 to the least numbers and multiply the total by 9.

The Third Game

The third game is *tangram* (Fig. 5.3) which is a Chinese puzzle and a type of dissection puzzle. A *tangram* consists of forming a square. The objective is to form a specific shape with seven pieces. The shape has to contain all the pieces which may not overlap. The pieces are 5 right isosceles triangles (2 small, 1 medium size, 2 large size), 1 square and 1 parallelogram.

The Fourth Game

Fourth game is a *matchstick puzzle* (Fig. 5.4). There are many puzzles using matchsticks. We have taken three very simple examples just to create interest in shapes. The first example is to make 8 triangles using 6 matchsticks. Second example is to change the direction of swimming fish by replacing match sticks from a particular shape.

The Fifth Game

The last game is a *magic square*. There are thousands of magic squares but we have taken just two examples. This game is based on simple logic involving numbers of boxes and addition. In the first example the boxes numbered 21–29 are to be arranged in such a manner that the total sum of each side comes out to be 75, second one has numbers 46–54 and the total should be 150.

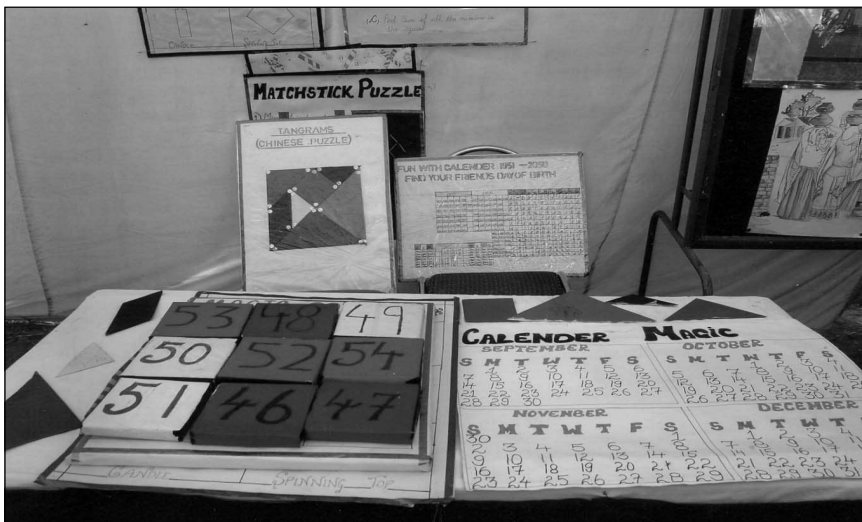

Fig. : 5.1

October						
S	M	T	W	T	F	S
			1	2	3	4
5	6	7	8	9	10	11
12	13	14	15	16	17	18
19	20	21	22	23	24	25
26	27	28	29	30	31	

Fig. : 5.2

RULES

- (i) Take any 3 3 square.
- (ii) Find sum of three umbers in a row, or a column or diagonally.
- (iii) Find sum of all the numbers in the square.

The *Tangram* Puzzle

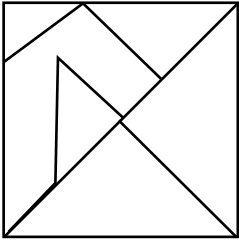

Square

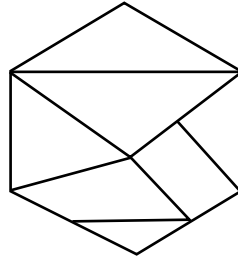

Hexagon

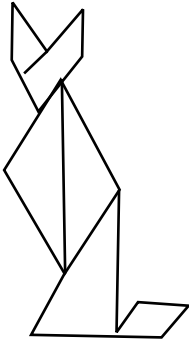

Cat

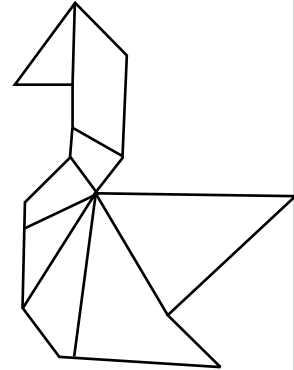

Swan

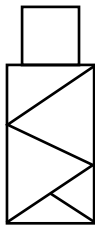

Candle

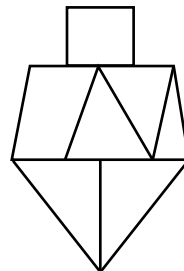

Swan

Fig. : 5.3

The Matchstick Puzzle

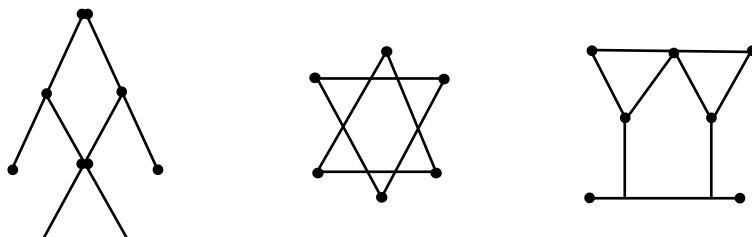

Fig. : 5.4

The Magic Square

Sum of 75 →	25	27	22
	21	25	29
	28	23	24

Sum of 150 ↴	53	48	49
	46	50	54
	51	52	47

Fig. : 5.5

REFERENCES

Math Magic Book, Classes III-V.

INDIGENOUS INCUBATOR

STUDENT

Vanlalhruaia

St. Lawrence School

Ramthar, Aizawl

Mizoram

TEACHER

Anil Kumar

INTRODUCTION

Food is important in our life and meat usually forms an essential part of diet in many cases. As population grows every year, consumption of food is also increasing. So, the means for producing food must also be increased to meet the requirements of people. In this model we have developed an easy and low cost incubator to hatch eggs in large numbers.

SCIENTIFIC PRINCIPLE INVOLVED

It takes 21 days to hatch eggs at a constant temperature of 107 F. To get the necessary constant temperature required for hatching the eggs, the combined properties of air and electricity can be used for making an indigenous thermostat. These are as follows:

- (i) Air expands due to heat and contracts at low temperature.
- (ii) Electricity produces heat and light.

MATERIALS REQUIRED

Plywood, timber splitted pieces, thermocol, electric bulb, flexible wire, small empty fruit juice tin, balloon, two carbon rods, fevicol, nails, thermometer etc.

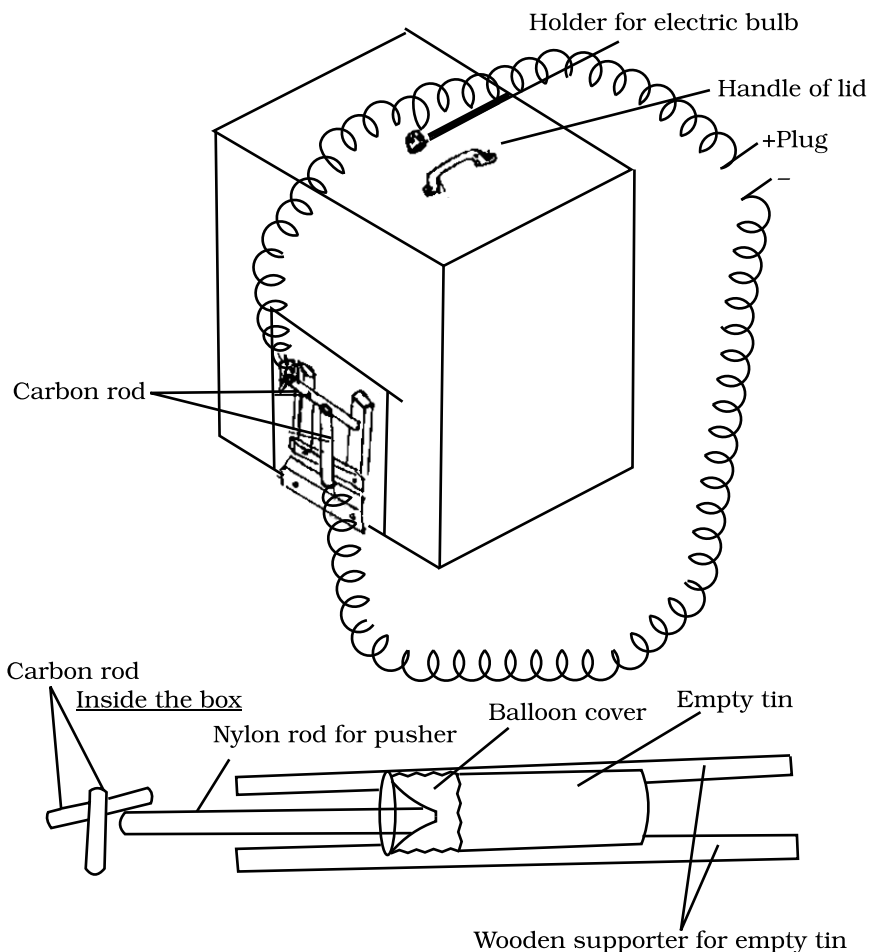

Fig. : 6.1

CONSTRUCTION AND WORKING

A cubic box of $1\frac{1}{2}$ square feet sides is made with a lid in the upper side (Fig. 6.1). Thermocol is fixed on all the inner sides of the box for insulation of heat. An electric bulb is fitted in the centre of the lid. A small empty fruit juice tin is closed at the mouth with a an air tight balloon, and placed inside the box. A small light plastic rod is put at the mouth of the tin so that it touches the balloon.

The other end of the rod protrudes outside the box through a hole, made at one side of the box. Two carbon rods are fitted outside at the place where the plastic rod is fitted. These carbon rods are fitted in such a way that they can act as thermostat when current is passed through them.

When the switch is on, the bulb glows and produces heat inside the box. Due to the heat, the air in the fruit tin expands and it pushes the balloon forward. Thus, the pusher rod is pushed *forward*. When the end of the rod touches one of the carbon rods, the temperature inside the box should be around 150 F. The glowing of bulb stops because the carbon rods are no longer in touch with each other as one of them is pushed forward by the pusher rod. Then the temperature inside the box decreases slowly. The pusher rod also comes *backward* by the action of a rubber band acting as a spring. After a few seconds, the carbon rods are in touch again and the bulb starts glowing again. This process continues to repeat again and again to maintain the temperature in the box constant at around 107 F.

The eggs put inside the box at the bottom hatch after 20-21 days.

GEOTHERMAL DESALINATOR

STUDENT

Sheik Naveedul Haq

Government High School

Zaloor

Teh. Sapore, Baramula

Jammu and Kashmir

TEACHER

Showkat Hussain Bhat

INTRODUCTION

The aim of the model is to convert saline (brackish) water into fresh drinking water on a large scale by the usage of geothermal energy.

MATERIALS REQUIRED

Two tanks, one U-shaped metallic pipe, one box, one spirit lamp, cubes of ice.

CONSTRUCTION

The construction of the model is simple as the two tanks placed at the same level are connected with the two ends of U-shaped metallic pipe. One tank acts as an input storage tank of saline or brackish water which is pumped down to a given depth through a U-shaped pipe and the other end of the pipe is connected to another tank which acts as a condensation tank where the steam collected from the given depth is condensed into fresh water.

PROCESS

This model of the geothermal desalinator shows the way we use geothermal energy for the desalination of saline or brackish water, and make it fit for drinking and irrigation.

The process of the project is simple as it works on the temperature of the earth's interior that increases with depth. A temperature of about 300 C normally occurs at the depth of about 10 kms. Therefore the cold brackish water is pumped down to a given depth in the earth's crust through a bore well (Fig. 7.1), where it is heated up by the thermal flow and the steam produced is emitted from the bore holes and is collected as it comes to the surface. The steam thus collected is passed through the cold tank where it condenses into fresh water for use.

APPLICATION

This project has great application in daily requirements of our life as most of the coastal places in the world suffer from the availability of fresh water, because the sea water is saline and not fit for drinking, washing and irrigation. So desalination is the only way to obtain pure water from salty or brackish water.

ADVANTAGES

- (i) It is an eco-friendly project as it does not require any fossil or nuclear fuel.
- (ii) By using this type of desalinator we can protect our environment from pollution caused by burning of fossil or use of nuclear fuels.
- (iii) It is a low cost project as it does not require any fuel.
- (iv) It helps in the control of global warming that is caused by the use of fossil and nuclear fuels.

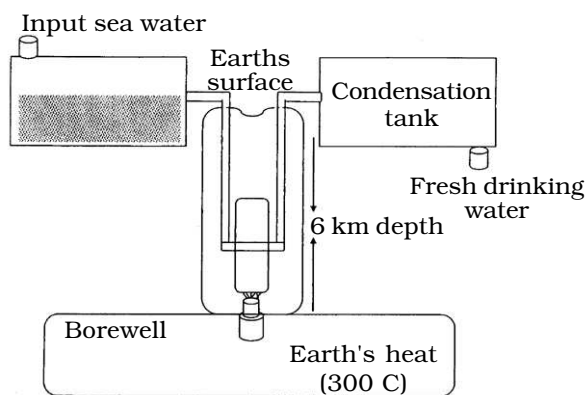

Fig. : 7.1

Structure and Working of Science Models

EATABLE SPOONS ECO-FRIENDS

STUDENT

A.Priyanka

B.Mani Tejaswi ment High School
P. Dornala
Prakasam
Andhra Pradesh

TEACHER

V. Nagamurthy

INTRODUCTION

Now a days we use plastic cups, spoons, glasses, plates etc., enormously. No doubt, the plastic plays a dominant role in the present world. We use them in parties and functions. The plastic garbage is seen everywhere in our cities, towns, and even in villages. If we go on throwing this plastic material everywhere, after some years it forms a layer on the ground. This layer does not allow the rain water to seep into the deeper level of the ground. So it leads to lowering of ground water level. Finally we are likely to face a severe drought situation. It is a great threat to life. So, it is necessary to develop the project "Eatable Spoon Eco-friends."

MOTIVATION

We are aware that usually icecream is available in plastic cups. We also have the icecream in cones. We eat those cones with the icecreams.

You know that we use spoons when we take *idli- sambar*, but we use a piece of *rotti* as a spoon when we eat *rotti* and *dall*. Similarly, can we adopt the same system in our day to day life? The answer to this is eatable spoons eco-friends.

METHODOLOGY

We took the flour of rice, wheat, millet, cholem, maize, corn in a particular ratio, then mixed them well. Prepared spoons in

various designs and got them dried. Dried spoons were soaked into some sugar water such as *kheer*. We also observed the time for its preparation and the time for softening in water and other liquids. Finally we selected the best ratio of various flours for making spoons from them.

The Best Mixture of Flour Content

Corn	6 Parts	Wheat	2 Parts
Millet	3 Parts	Rice	2 Parts
Cholem	2 Parts	Maize	1 Part

<i>Sl. No.</i>	<i>Content of Flour Used in Preparation of Eatable Spoons</i>	<i>Time Taken for Softening in Water (in minutes)</i>	<i>Time Taken for Softening in Kheer (in minutes)</i>
1.	Wheat flour	15	22
2.	Rice flour	17	22
3.	Cholem flour	19	25
4.	Millet flour	19	24
5.	Wheat + cholem flour 1:1	21	27
6.	Wheat + cholem+ Rice flour 1:2:1	25	32
7.	Wheat + millet + Rice flour 1:2:1	20	21
8.	Wheat + Rice flour 1:1	18	24
9.	Millet + cholem flour 1:1	21	28
10.	Corn + cholem + millet + Wheat + Rice flour 3:2:2:1:1	22	28
11.	Corn + cholem + millet + wheat + Rice flour 3:1:1:2:2	24	30
12.	Corn + cholem + millet + Rice flour 4:2:2:3	23	30
13.	Corn + millet + cholem + wheat + Rice + Maize flour 6:4:2:2:2:1	31	39
14.	Corn + millet + cholem + wheat + Rice + Maize flour 6:3:2:2:2:1	33	42
15.	Corn + millet + wheat + Rice + Maize flour 5:3:2:3:2	27	34

Do You Know?

- (i) Eatable spoons are eco-friendly.
- (ii) Plastic takes one lakh years for its destruction.
- (iii) If we eat the cups and spoons in place of throwing, Wow! What an idea?

OBSERVATIONS

- (i) Eatable spoons do not harm the ecology.
- (ii) We can get the desirable designs of spoons with the help of microwave oven.
- (iii) A lot of experiments could be done on it.

SOLUTIONS

- (i) Strict action should be taken to reduce plastic pollution.
- (ii) Use eatable spoons instead of plastic spoons.
- (iii) Government should encourage the process of making eatable spoons as cottage industry.
- (iv) Make the people aware of the importance of ecological protection.
- (v) This concept should be improved by further research.

CONCLUSIONS

- (i) Government should encourage to do some research in this respect.
- (ii) Children should invent new things, like eatable spoons eco-friends.
- (iii) We should prepare eatable cups, plates and other things like eatable spoons.
- (iv) Every one should take active participation in protecting the ecology.
- (v) Plastic is an invisible devil that consumes our life span.
- (vi) Reduce plastic – develop eatable spoons eco-friends.

ENERGY PRODUCTION FROM HEAT OF SUNLIGHT FALLING ON THE ROOF OF THE BUILDING

STUDENT

Arijit Deka

Maharishi Vidya Mandir
Public School-1, Silpukhur
Guwahati, Assam**TEACHER**Nayana Das

INTRODUCTION

With the growing demands of human needs the utilisation of conventional energy has increased tremendously. Consequently environmental issues like global warming etc. have risen. Keeping these facts in view this model has been prepared to present an idea on how the daily energy requirement can be fulfilled in a more practical, feasible and economical way by converting solar energy into electric energy.

MATERIALS REQUIRED (FOR THE ACTUAL CONSTRUCTION)**The Conical Hollow Dome**

A high dense and durable plastic to construct the dome shaped cone. It should be made up of some light weight material like Syntax tank material.

The Rubber Pipes

High tensile, light-width, durable rubber pipes that can carry heated air without being heated and eroded easily.

The Turbines

A turbine having less number rotations per minute as the number of pipes connected to the dome, are typically six to eight and

another turbine having more numbers of rotations per minute as it is fixed at the top level. Besides these, we need an electric pole that acts as supply line, electrical wires for wiring that is generally done in houses and an inverter to convert DC current to AC.

MATERIALS REQUIRED (FOR THIS MODEL)

Old cardboard box for the house, old cable wires for the pipes, funnel for the conical dome, chart/marble paper for designing the house, cardboard for the base, razor blade for electric pole.

SCIENTIFIC PRINCIPLE INVOLVED

This model is based on the principle of Bernoulli's theorem. There is an increase in speed of the fluid with decrease in the pressure and vice versa.

CONSTRUCTION

It is a domestic model and can be set up on the rooftop of the houses. Since, the entire project is based on utilisation of heat from the rooftops, the requirement is a strong typical roof, above which the conical dome is set up. The broader base of the dome is fitted on the roof and a cylindrical pipe is fitted to its narrower base. A powerful turbine is fixed at the top of this pipe which is then connected to a generator.

There are a number of hollow curved pipes. The one end of these pipes is fixed to the region of the house where ventilation is to be made and the other end is fixed at a region above the base of the dome. Every wall of the house is connected to the dome through a pipe.

Provision can be made to connect pipes from the rooms of every floor for a multi-storeyed building.

A less powerful turbine is fixed at the mouth of every pipe opening in the conical hollow dome.

WORKING PROCESS

The process starts from the conical dome itself. It gets heated up quickly. Therefore the process of conduction heats up the air inside it. Warm air rises up and runs the turbine-cum-generator fixed at the top of the cylinder (Fig. 9.1). So to fill this empty space, the air inside the building is sucked into the dome through

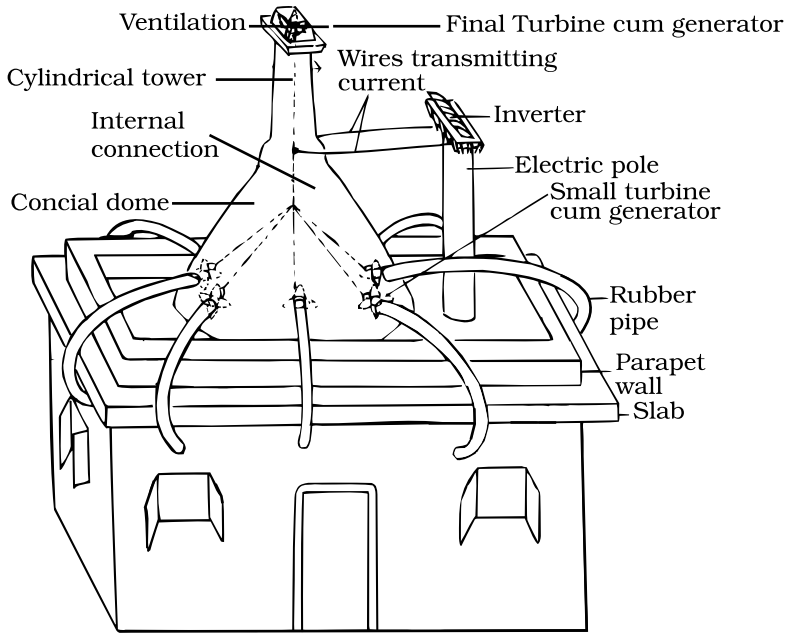

Fig. : 9.1

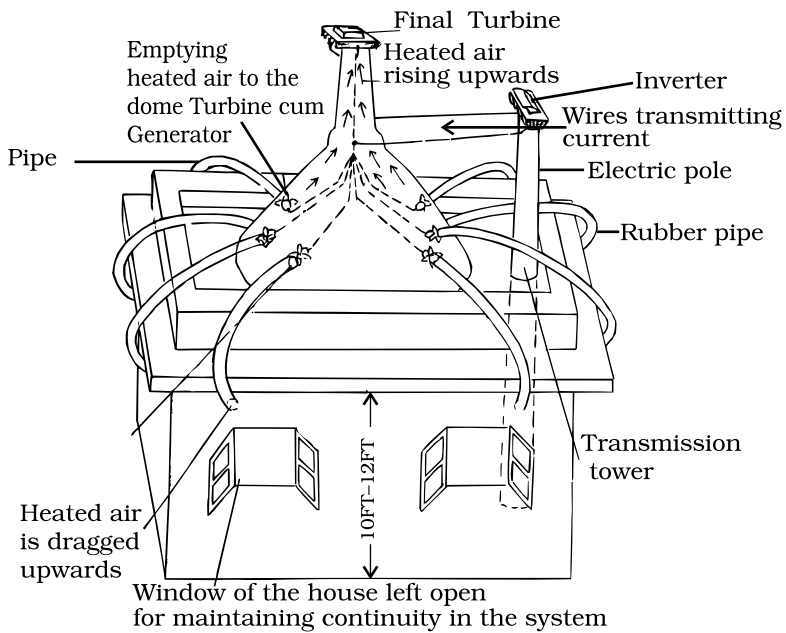

Fig. : 9.2

the pipe (Fig. 9.2). The air inside the building is preheated since the roof is black in colour.

The room of the house is kept open. During the day time, as the air outside is already heated from the solar energy, it enters to low-pressure region inside the house. The pipes that are already fitted beneath the roof, transport this heated and pressurised air to dome. When passing through the thin pipe fitted at the base of the dome, it is forced to increase its velocity, thereby reducing pressure, (Bernoulli's theorem). The turbines fixed at the mouth of every pipe are run by the warm air. The air further rises up with greater velocity and moves turbine fixed at the top which runs the generator.

The electric current that is produced is passed to the internal connection of wires, which is linked with the main wirings of the house on a pole. Here, the generated current is transformed into AC and is supplied to the different rooms of the house. Since, there is continuous flow of air and the lower level of air is left undisturbed, we feel cool inside the house without the use of air cooler or air conditioner.

APPLICATIONS

Since this model is entirely home made thus, it is very useful, practical and economical.

- (i) For a family consisting of five members, the minimum electrical energy requirement per day is 2–3 kW. If this model is built in the region where it has maximum potential, i.e., in the arid climatic region or if it is set up at the top floors of multi-storeyed buildings receiving much heat of the sun, the output would be sufficient to meet the requirement of an average house.
- (ii) It keeps the room cool, thereby cutting down energy requirement by the use of coolers or air conditioners.

SAFETY ALARM FOR LPG LEAKAGE

STUDENT

Agri K. Hasmukhbhai

Government High School

Dokmardi

At Amla, Post Silvassa

Dadra and Nagar Haveli

TEACHERShukla Paritosh Vijayakant

INTRODUCTION

It is very essential to have devices in every house to protect domestic accidents. This model aims at making people aware of use of simple techniques for safety at homes.

RATIONALE BEHIND THE CONSTRUCTION OF THE EXHIBIT

It is observed that in day-to-day usage of LPG (Liquified Petroleum Gas) in kitchens, enough care is not taken with respect to LPG devices and gas stove. Every now and then serious accidents occur. Leakage of LPG cylinder causes fire and harm to human-life. For preventing such accidents, it is essential to have safety precautions at homes. For this purpose, using the advanced technology in the field of Electricity, this 'Safety Alarm' has been innovated.

SCIENTIFIC PRINCIPLES INVOLVED

This is an electric circuit comprising different values of resistances, capacitances, diode, LED, Gas Sensor Unit (MQ-4) and lighting as well as buzzer (for alarm). When the leakage of gas occurs, the space around the detector unit of the circuit containing heater is occupied by butane-gas, which works as a good resistor. Thus, the circuit is completed and device of alarm functions automatically by lighting and buzzer.

MATERIALS REQUIRED

Acrylic-sheets, resistors, capacitors, star-sencor, LED, PC Board, copper wires, buzzer, lighting-lamp, soldering-wire and soldering gun etc.

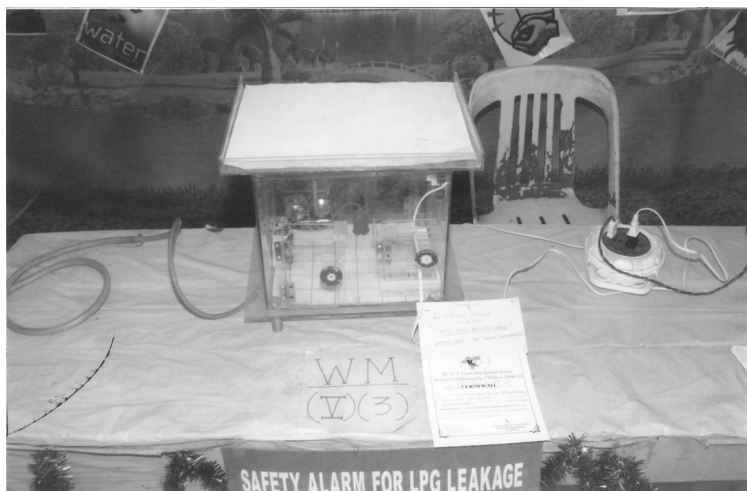

Fig. : 10.1

CONSTRUCTION AND WORKING

The model is a very useful device to prevent leakage of LPG from LPG cylinder (Fig. 10.1). Of course, the cylinder has regulators and valve for its operation. LPG is a mixture of fuel gas, butane and merkepton. Here merkepton is added as it has very bad odour. The bad odour in room-air indicates the presence of LPG in the room. But some times the odour cannot be recognised easily from the adjoining rooms. Under this circumstance, the model safety alarm will prove useful.

The electric-circuit as shown in Fig. 10.2 is completed on a PC board. The necessary wiring to connect capacitors and resistors is done systematically. Thus, the main device is prepared. The unit is to be placed in the kitchen and near to the stove and gas-cylinder. The other part, alarm device is consisting of lighting-lamp and buzzer is kept and connected in the central living area of the house.

As and when, the leakage of LPG takes place, the released gas reaches around the detector unit and the circuit is completed.

Thus, current passes in the circuit and parts sensor and LED are also joined in the circuit at proper place. The lamp is turned on and the buzzer produces sound at once. It is also possible to stop the leakage by using automatic valve-device attached to the gas-pipe and at its joint with the cylinder.

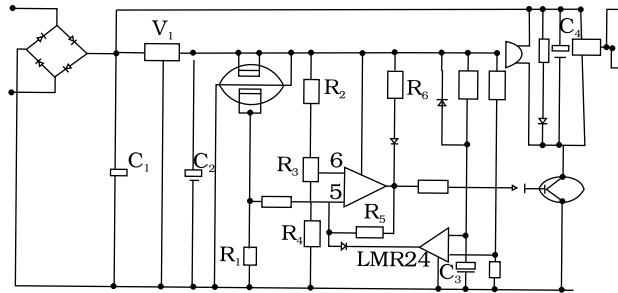

Fig. : 10.2

APPLICATIONS

- (i) Every house having gas connection either of gas cylinder or natural gas pipeline can get safety from fire accident by using the alarm unit.
- (ii) The cheaper device can be manufactured in large quantity and be provided to many families.
- (iii) LPG users like hotels, canteens, public-offices etc. also can be benefited by this alarm unit.
- (iv) The maintenance of this unit is very easy and it can also be seen that the scheme of the unit is unfailling. Thus, system works with 100 per cent guarantee.

REFERENCES

Gujrati Book, *Akasmata Nivaran*

USEFUL PRODUCTS FROM FISHERY WASTE

STUDENTS

Jameil S. Kolliyil
Sabin Raj
Sharath T S
Jerin Joe

Kendriya Vidyalaya
Port Trust, Kochi
Kerala

TEACHER

Ajith S R

INTRODUCTION

Explosion in scientific development and technologies have led to the widespread depletion of our natural resources. These technologies have helped the marine and fisheries sector to develop at a very fast rate. As a result, the production of fishery products have increased with leaps and bounds. But at the same time, the wastes from the fishery industry have also increased at the same rate. The disposal of waste is causing great environmental problems at present. India is one of the leading producers of shrimps in the world. Fish processing industry in India produces over 60,000 tonnes of crustacean waste annually, comprising mainly the head and shell of prawns. Through eco-friendly processes, useful products like protein and calcium could be produced from shells and bones of fishery waste.

SCIENTIFIC PRINCIPLES INVOLVED

Chitin a long straight chain natural polymer of N-acetyl-D-glucosamine is abundantly available in the exoskeleton of crustaceans (shrimps, crabs, lobsters and squilla). Chitosan is a deacetylated derivative of chitin. The process involves the following steps:

1. Preparation of Chitosan

- (i) Deproteinisation;
- (ii) Demineralisation;
- (iii) Deacetylation;
- (iv) Drying.

2. Extraction of Calcium

(i) Deproteinisation using an enzyme; (ii) Deactivation of enzyme; (iii) Drying and pulverisation.

MATERIALS REQUIRED

Shells of crab, shrimps, lobster, acetic acid, sodium hydroxide, net, steel vessel, water.

RAW MATERIAL

Use fresh wet shell and head as far as possible. Spoiled wet shell will give only a product of inferior quality. If only dry shells are available, those too can be used. Wash the raw materials thoroughly in water to remove adhering sand, dirt, etc. and drain out water.

SEPARATION OF PROTEIN (DEPROTEINISATION)

The objective of the process is to remove the protein present in the head and shell of crustaceans. Take the washed and drained shells in a steel vessel of sufficient capacity having arrangement for heating.

EXTRACTION OF CALCIUM FROM FISH BONES

Usually the fish contains 5-8 per cent bone. Fish bone is rich in calcium as dicalcium phosphate which has the ideal calcium - phosphorus ratio (2:1). Fish calcium is natural, micro crystalline and easily absorbable. The mineral content of fish usually has 70-80 per cent calcium and phosphorus, the two essential minerals required for human body also. Add sufficient quantity of 3 per cent sodium hydroxide solution. Boil for 30 minutes and allow cooling. When the residue is settled, decant the solution, which contains protein from head and shell. Wash thoroughly with water to remove the alkali completely.

REMOVAL OF MINERAL (DEMINERALISATION)

Transfer the residue to a vessel. Add sufficient quantity of dilute (5 per cent) hydrochloric acid. The acid added should be more than sufficient to complete the reaction but care should be taken not to add higher concentration of acid. Keep for 30 minutes and decant the excess acid containing the mineral from the

crustacean shell and head. Wash the residue with water repeatedly to free from any excess acid.

REMOVAL OF WATER

Collect the acid free residue in a canvas and press under screw press to remove the water content as far as possible. The product obtained is chitin with moisture content of 60 per cent.

CONVERSION OF CHITIN TO CHITOSAN (DEACETYLATION)

Transfer the residue into a mild steel vessel and add 40% sodium hydroxide. Heat the contents at 90-92 C for about 1½ hours. By this time chitin will be converted into chitosan, which can be tested by the solubility of the material in 1 per cent acetic acid.

REMOVAL OF WATER

Collect the residue in a canvas and press under screw press to remove the water content as far as possible. The product obtained is wet chitosan.

DRYING

Dry the product under the sun to reduce moisture content below 5 per cent. Under bright sunlight the product can be dried within 6-8 hours. Alternately, artificial drier can be used for drying the product. The product will be in the form of colourless flakes.

POWDERING

Powder the product with a good quality of pulveriser to get coarse product.

APPLICATIONS

- (i) As an additive to paper to improve the properties of newsprint and other paper and increase strength towards wet and dry conditions.
- (ii) As an additive to improve the wet strength properties of other wood products such as paper towels, grocery bags and dispersible baby diapers and non-woven fabrics and provide strength towards wet conditions.
- (iii) As an additive to baby food formulation.

- (iv) As an additive to stomach antacids.
- (v) In the treatment of wounds.
- (vi) In textile finishes and shoe polishes.
- (vii) As a water clarifier during under sea explorations and exercises, search and recovery operations, diving expeditions.
- (viii) Retaining the dye in better way.

EXTRACTION OF CALCIUM FROM BACKBONE

- (i) Backbone of fish (tuna) is collected from processing plant.
- (ii) It is washed thoroughly.
- (iii) Washed bones are deproteinised with papain enzyme (from papaya) in the ratio 1:00 at 55 C for 2 hours.
- (iv) The enzyme is deactivated by boiling the contents for 10 minutes.
- (v) Deproteinised bones are washed thoroughly and sun dried.
- (vi) Dried bones are pulverised to a fine powder which is calcium.

TEST FOR CALCIUM

Flame Test

The obtained calcium is added to conc. HCl and made a paste. When kept over the blue flame of a burner, a red flame is obtained.

APPLICATIONS

- (i) Calcium obtained from the fish bone is low cost calcium.
- (ii) Purified fish calcium can be added to food supplements.
- (iii) As commercial calcium tablets are not natural, tablet made of fish calcium can be used.

REFERENCES

www.wikipedia.com
Encyclopaedia Britannica
www.google.com
www.cift.com

SELF-SUFFICIENT HOUSE

STUDENTS

Sandhya Bhatia
Shaifali

Rajkiya Pratibha Vikas
Vidyalaya, Surajmal Vihar
Delhi

TEACHER

Girija Shankar

INTRODUCTION

In the construction of Self-sufficient House, reuse of plastic waste has been made. Recycling of waste water and use of renewable energy sources have been done.

RATIONALE BEHIND CONSTRUCTION OF EXHIBIT

- (i) Heaps of waste plastic adding to environmental pollution.
- (ii) Depletion of non-renewable sources of energy.
- (iii) Wastage of water.
- (iv) Global warming leading to increase in carbon dioxide level.

SCIENTIFIC PRINCIPLES INVOLVED

- (i) Use of renewable sources of energy.
- (ii) Re-cycling of waste water for hydraulic lifts and terrace gardening.
- (iii) Re-use of waste plastic by combining it with clay and wood shavings to conserve natural resources.

FEATURES

- (i) Re-use of plastic waste.
- (ii) Rain water harvesting and hydraulic lift.
- (iii) Floating type biogas plant.
- (iv) Use of solar energy for electric power generations and transport.

- (v) Terrace gardening – resistant to climatic changes.
- (vi) Trees – maintaining carbon dioxide level with oxygen.

MATERIALS REQUIRED

Waste plastic and wood shavings, solar cells, water pump, piston, grass, clay.

RE-USE OF WASTE PLASTIC IN CONSTRUCTION

The plastic that contributes to the heaps of wastes in our country is used here for advantageous purpose and removing waste from the country.

BRICKS

Bricks are made using plastic and clay for further construction of strong and anti-ceiling house.

FURNITURE

To make the furniture we require some wood shavings that are already waste for a carpenter and waste plastic is mixed with it to get the final product which is further given the shape of different types of furniture.

TERRACE GARDENING

In this we have grown some Mexican grass at the roof of the house that remains unaffected from any climatic change. This is also a very advantageous and interesting feature and makes the house self sufficient.

GARDENING AROUND HOME

Gardening around home is also done that utilises the biogas residue. It also maintains and balances the oxygen and carbon dioxide level. Biogas is produced from waste material. Bacteria carry out the decomposition or fermentation (Fig. 12.1). The conditions for creating biogas have to be anaerobic that is without any air and in the presence of water. The organic waste matter is generally animal or cattle dung, plant wastes, etc. These waste matter are soaked in water to give the bacteria a proper medium to grow. Absence of air or oxygen is important for decomposition of waste material. The main gases released are methane, carbon

dioxide, hydrogen and hydrogen sulphide. It is utilised for cooking purpose due to its calorific value.



Fig. : 12.1

WATER HARVESTING

For some requirements of the house we can use less purified water. For this there is need for "On Site Water Supply and Waste Water Treatment", we can harvest abundant rainwater from the roofs of our houses and channel it all via a filter to an underground storage tank and from here pump it into the house (Fig. 12.2). The natural soft rainwater is fit for use in washing machines.

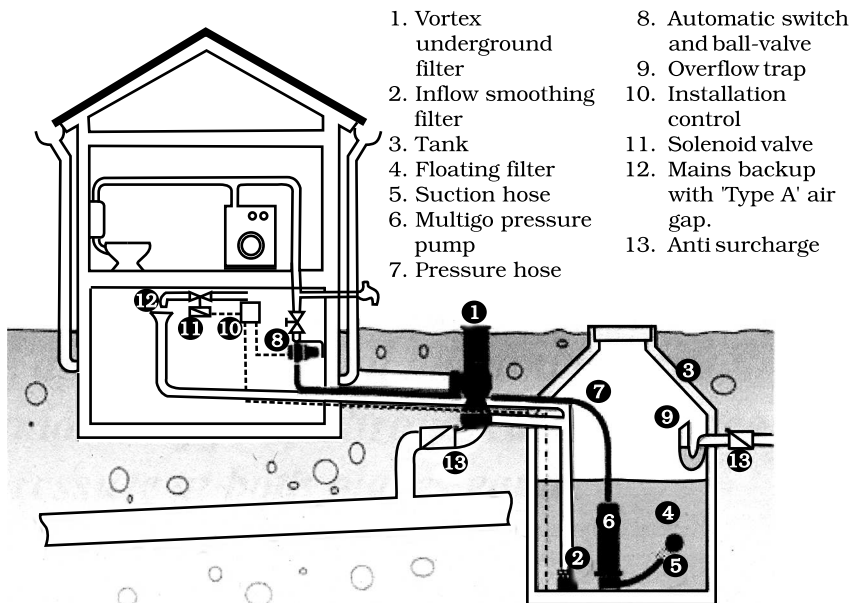

Fig. : 12.2

PRINCIPLE OF HYDRAULIC LIFT

This is based on the principle of Pascal's Law.

We use this theory in hydraulic lift which has been installed in our self sufficient house in which small force is applied at a area.

USE OF SOLAR ENERGY FOR ELECTRIC POWER GENERATION

The way for generating electricity in our self sufficient house is through solar panels [photovoltaic cells] that involve use of solar energy in different modes according to the amount of absorbed light.

In this we have fixed solar panels (Fig. 12.3) on the roof of the house. These absorbs solar energy and convert it to electrical energy.

Using fuel cell we can store that energy and whenever there is no sunlight we can use them for three purposes as follows:

- (i) Electricity generation
- (ii) Hydrogen production that can be further used for automobiles.
- (iii) Much needed water production.

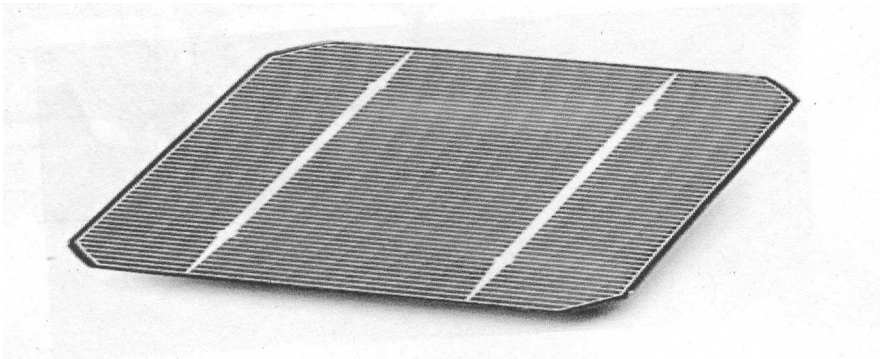

Fig. : 12.3

REFERENCES

www.wikipedia.org
Science Reporter
The Times of India

INNOVATIVE FIRE INTERCEPTING DEVICE

STUDENT

Aritra Choudhary

South Point School
Ballygunge Place, Kolkata
West Bengal**TEACHER**Sukanya Barman

INTRODUCTION

This exhibit is better than available Fire Alarm Systems. In the existing Domestic Fire Fighting System, there is either a Heat detector or a Smoke Detector, which on activation, rings fire alarm and water spray is used to fight fire.

In this model a unique system has been developed. In this device, heat detector and smoke detector have been used simultaneously. Also smoke detector has been modified to make an automatic system which will differentiate classes of fire on the basis of nature, quantity and density of smoke and deploy water in case of Class A and CO_2 foam in case of Classes B and C.

SCIENTIFIC PRINCIPLES INVOLVED

Classes B and C fire emit dense sooty black smoke due to partial thermal decomposition of hydrocarbons.

Hydrogen undergoes combustion to form water vapour while a very little part of carbon is oxidised to CO_2/CO . Most of the carbons remain in its elemental form. This carbon in its fine particulate state, mixes with the gases and water vapour to form the dense black smoke.

MATERIALS REQUIRED

Solenoid valve, control panel, smoke and heat detector, relay, hooter; 2 12 V battery, necessary pipe work.

CONSTRUCTION AND WORKING

The system has two parts which are mentioned below:

THE DETECTION AND EXTINGUISHER DEPLOYING PART

This part uses sensors to detect and judge the class of fire and deploy extinguisher accordingly.

The schematic diagram of working model is shown in Fig. 13.1, 24 V DC is connected to Heat Detector (HD) and Smoke Detector (SD).

When only HD senses heat (without SD sensing smoke), electricity activates the solenoid valve meant for spraying water and sounds alarm. But when SD senses smoke (without HD sensing heat for example, somebody is smoking), it just sounds an alarm but the CO₂/foam valve will not be opened since the relay is not activated. It also activates the circuit breaker the circuit between the water valve and HD.

The entire working of the system is explained in the table given below:

<i>Heat Detector</i>	<i>Smoke Detector</i>	<i>Alarm</i>	<i>Water Spray</i>	<i>CO₂/Foam</i>
Activated	Not activated	Yes	Yes	No
Not activated	Activated	Yes	No	No
Activated	Activated	Yes	No	Yes
Not activated	Not activated	No	No	No

SPRINKLE OR WATER SPRAYING SYSTEM

This system uses optical sensor to detect the location of fire and sprays the extinguishing material in that direction only. This system consists of a circular platform with 4-6 photodiode based optical sensors. Each sensor is connected to the electrically actuated solenoid valve. When fire breaks out, light from the fire excites the photodiode of optical sensor, facing the fire and opens the valve in that direction only as shown in Fig. 13.2.

APPLICATION

The device is an ideal for domestic fire fighting, especially when fire breaks out without the knowledge of dwellers e.g. person sleeps with burning cigarette in hand, and fire breaks out from it,

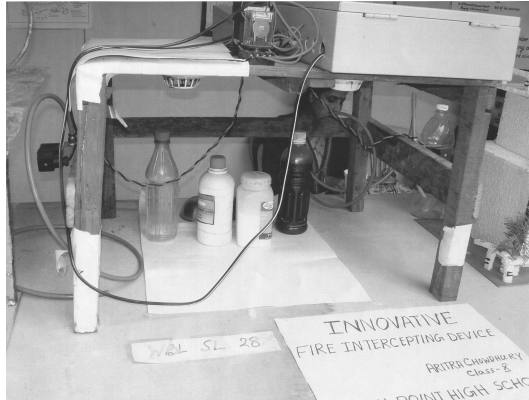

Fig. : 13.1

he will be saved by the system. The system is fully automatic without requiring any human interference. It can be operated by battery power, hence will work during power cut also.

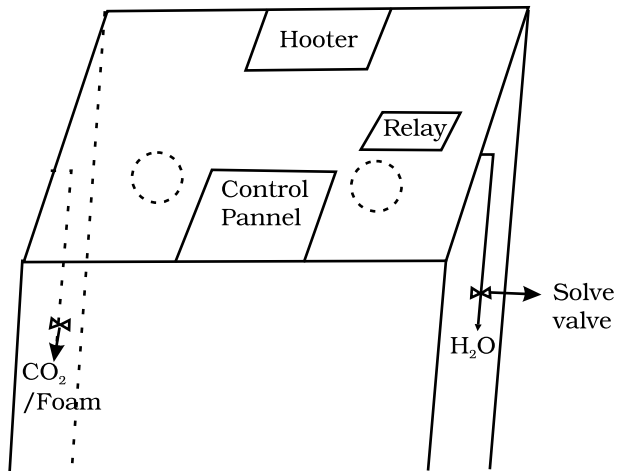

Fig. : 13.2

MULTIUTILITY BIOPRODUCT SYSTEM

STUDENTS

Sagar Padole
Shadab Tauhid Abdul Waheed
Shantanu Vivekrao Nichit

Deepshikha Gurukul
Sainik School
Chikhaldara
Amravati, Maharashtra

TEACHER

Mahesh Purushottam Chikhle

INTRODUCTION

In Vidharbha, main problem is farmer suicide due to non-fertility of soil or high cost of chemical fertilisers. Non-fertility of soil is due to more use of chemical fertilisers. Aim of our project construction is to produce liquid fertiliser by utilising human urine and *Gomutra* (cow-urine). Human urine is the fastest acting, excellent source of nitrogen, phosphorous, potassium and some other elements. In addition, we have a constant, year round supply of it and it's free! It is a wonderful organic fertiliser. The high level of nutrients in our effluent systems lead to the growth of algae, which ultimately causes the death of plant and animals living in water.

SCIENTIFIC PRINCIPLES INVOLVED

- (i) Urine contains ammonia, urea and metal ions.
- (ii) Generally urine or *Gomutra* (cow-urine) is not used in biogas production, i.e., methane gas.
- (iii) Urine contain ammonia which is responsible for decrease (supress) in the light of methane gas.
- (iv) By heating urine dissolved ammonia is collected in the form of ammonia solution.
- (v) Remaining slurry and biodegradable waste is used for production of methane gas.

- (vi) Capillary action, i.e., oil rises up in the wick due to capillary action because of force of surface tension.

MATERIALS REQUIRED

Aluminium cans as boiler, rubber pipe, waste oil – can (plastic and iron), plastic pipe (4" inch) waste, gas burner, tripod stand, hardboard, bicycle clutch and clutch-wire, spring, plywood, spray pump, human urine, biodegradable material, cotton thread, chemical for (qualitative test) – Nessler's reagent, BaCl_2 .

CONSTRUCTION

- (i) Build specific urinary chamber, containing two holes, one hole for water outlet and another hole for urine outlet.
- (ii) Urinary outlet hole opens into urine collection chamber.
- (iii) Urine collection chamber is connected to boiler with the help of a pipeline.
- (iv) Boiler has three opening i.e., one is urine inlet, second is slurry outlet and third is connected to condenser.
- (v) Hot vapour from boiler is passed into condenser where it is cooled to get ammonia solution. Condenser is made of plastic waste bottle and rubber pipeline. The running sewage water is used in condenser.
- (vi) Ammonia solution is collected into ammonia storage tank.
- (vii) The sewage water after passing through becomes hot and undergoes some purification, which is used for agriculture.
- (viii) Slurry from boiler passes through slurry pipeline and comes out of slurry and is collected into slurry storage tank outlet.
- (ix) Some slurry deposited in decomposition chamber is used for production of methane gas.
- (x) Drainage or sewage water is utilised for condensation of ammonia vapour. Before using for condensation sewage water undergoes purification in the purification tank attached to drainage system through a pipeline. After purification it is stored into storage tank.

WORKING

Human urine from the urinal is collected in the urine boiler (Figs. 14.1 and 14.2). It is heated upto 90-98 C. The hot vapour of urine are passed through a condenser in which sewage water

is circulated and boild urine is condensed. During circulation this waste water becomes hot and undergoes some percentage of purification which is utilised for agriculture. Thus we get ammonia solution.

Now, the boiler contains slurry which mainly contains sulphate, phosphate and some metal ions, which are very helpful for the growth of plant. Some slurry is directly used as a fertiliser and the remaining slurry is collected in the decomposer compartment with the help of slurry pipeline.

In the decomposer compartment, the disposable sewage waste can be added. The decomposition of sewage waste and slurry results in methane gas, which is used for heating boiler as well as other working purposes. After removal of methane gas, the decomposed material is used as decmposed fertiliser.

For the collection of pure urine we have built a special urine collection chamber. The urine chamber has two holes, when the person stands on the step, the knob below the step will be pressed and the hole for the passage of water will be automatically closed and urine outlet opens. The urine passes through the second hole and gets collected in a urine collector with the help of a pipeline. Urine from urine collector is passed to urine boiler for further processes.

By using rain water harvesting system, the roof water is collected in the underground water tank. When the person climbs the step, the knob below the step will be pressed. The underground tank water will be pumped and get collected into this overhead water tank. This water from the overhead water tank is used for clearing purpose. Same setup also solves the problem of parking around the public toilets.

For condensation we utilise drainage water which carries both degradable and non-degradable substance. The degradable waste is recycled and utilised for various processes.

Normally we use sewage waste water for vegetable production but it is harmful. Here, we purify this waste water in purification tank and get collected into the huge tank. Here, we use capillary irrigation system for vegetable production by purified waste water.

Main aim of our project is to decrease the percentage of ammonia in urine, because ammonia retards the process of decomposition. To show that this extract from the boiler is more alkaline than the remaining slurry in a boiler, we perform a litmus paper test. We all know that red litmus turns blue in alkaline solution. If we dip the red litmus paper in the sample of extract

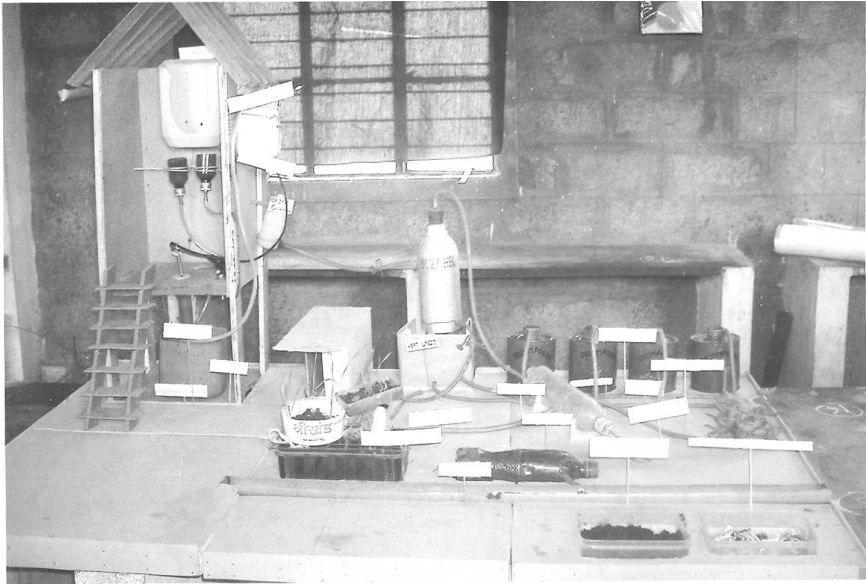

Fig. : 14.1

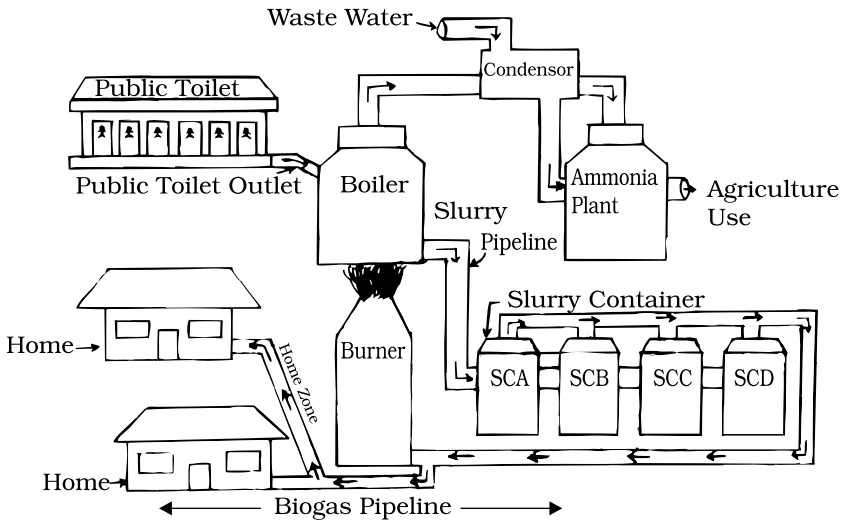

Fig. : 14.2

from the boiler, the red litmus turns dark blue. This test indicates that extract from the boiler is more basic than the remaining slurry in a boiler.

Now, if one or two drops of BaCl_2 is added to the slurry it changes its colour and forms white precipitate. This indicates the presence of phosphate and sulphate ions which are very helpful for the growth of the plant.

If a sample extract reacts with Nessler's reagent i.e., ammonia indicator. It forms brown precipitate. This indicates that the presence of ammonia can be directly used as a ammonia solution.

APPLICATIONS

- (i) The need for fertiliser is fulfilled by the farmer on their own.
- (ii) Production of bio-fertiliser and decomposed fertiliser from waste sewage.
- (iii) Biogas production for cooking, heating and lighting purposes.
- (iv) The proper management of waste reduces risk of diseases and pollution.
- (v) Sewage water purification and using it in agriculture production in limited space using capillary irrigation system.
- (vi) Pumping water without electricity.
- (vii) Removing the plastic wastes and saving the drainage from choking.
- (viii) Conservation of water through rain water harvesting system.
- (ix) Solution for parking problem around public toilet.

GLOBAL WARMING AND CLIMATE CHANGE

STUDENTS

Abhijith Thankachan
Anish C. Anushrut Khare
Shivaram L.S.

Atomic Energy Central School
Kudankulam, Tirunelveli
Tamilnadu

TEACHER

P.M. Thankachan

INTRODUCTION

Climate change is a burning issue and the whole world is discussing this topic in various platforms. UN has taken many steps to combat the climate change. Recently the G-8 summit held at L'Aquila, Italy discussed this topic in detail and made many resolutions to combat the climate change.

Keeping this in mind we have developed a working model to show the effect of global warming and the method to combat this problem. This model will give great awareness to the students and the public.

SCIENTIFIC PRINCIPLES INVOLVED

Due to rapid industrialisation, burning of fossil fuels and emission from the vehicles, the amount of carbon dioxide in the atmosphere is steadily increasing. The amount of carbon dioxide has increased from 0.03 per cent to 0.04 per cent. Carbon dioxide is one of the important green house gases. This gas is very important for maintaining the earth's temperature but due to more and more production of carbon dioxide the temperature of the earth is steadily increasing and this is known as global warming. Due to the global warming the polar ice-cap has started melting and this will cause rise in the sea level. Due to the rise in sea level the low lying land areas will be submerged which will cause loss of life and property. One of the best remedy for global warming is the

protection of our forest areas and afforestation. The plants absorb carbon dioxide gas for photosynthesis and release oxygen. By this process we get two valuable products i.e., food and oxygen.

MATERIALS REQUIRED

Earthen pot (medium size with some holes), one lid for the pot, candle or saw dust, one tray to display ocean, water (1 litre), blue ink, ice blocks, thermocol sheets-2 nos., sand or soil (3 kg), twigs of plants to represent forest, a few small houses.

CONSTRUCTION AND WORKING

Keep the earthen pots with hole on a side in a tray containing water (Fig. 15.1). Add a few drops of ink in the tray containing water. The tray is representing the ocean and the earthen pot represents the earth. Cover the mouth of the pot with a metallic lid. The ice on this lid represents polar ice-caps. The water containing tray represents the ocean. Lighted candle mainly produces carbon dioxide. The temperature rises and this represents global warming. Due to the rise in temperature the ice-blocks start melting and this raises the water level in the tray. The water in the tray overflows to the surrounding areas and the low lying areas starts submerging. It causes the loss of life and property of the people who are living in coastal areas. Another thermocol sheet with plants in it is kept separately. This represents afforestation which can prevent global warming. Thus global warming and climate change could be controlled by reduced emission of carbon dioxide and afforestation.

APPLICATIONS

This project gives awareness to the students and the public about the global warming. Gives an idea of the harmful aspects of the global warming. Gives message to the world that global warming is the root cause for climatic changes. Creates awareness about afforestation and conservation of the forest.

This project can be used as an effective educational tool to create awareness about impact of global warming.

To reduce the global warming we have to reduce the emission of green house gases by reducing the use of fossil fuels and depend on renewable energy resources.



Fig. : 15.1

REFERENCES

Down to Earth Guide to Global Warming by Laurie David and Cambria Gordon.

Global Warming the Complete Briefing by John Haughton.

The Discovery of Global Warming by Spencer R. Weart.

WEBSITES

[www.allianz.com/en/globalissue/climate change/global warming basics.](http://www.allianz.com/en/globalissue/climate%20change/globalwarmingbasics)

[www.climatechangeeducation.org.](http://www.climatechangeeducation.org)

[www.worldviewof globalwarming.org/pages/glacier.](http://www.worldviewofglobalwarming.org/pages/glacier)

भीड़भाड़ के क्षेत्र में भगदड़ पर नियंत्रण

छात्रा

कुंचना चौरे

राजकीय उत्कृष्ट विद्यालय, मुलताई
बैतूल, मध्य प्रदेश

अध्यापक

आर. के. मालवीय

गिरीश साहू

प्रस्तावना

यह मॉडल अचानक आने वाली आपदाओं पर रोक लगाने के उद्देश्य से बनाया गया है। इस मॉडल से हमारा अभिप्राय किसी बड़े क्षेत्र, मेले या किसी प्रसिद्ध एवं पौराणिक धार्मिक स्थल पर अचानक मची भगदड़ को रोकना है। इस मॉडल के अनुसार पहले ऐसे किसी भी स्थान के क्षेत्रफल की गणना करके ज्ञात करते हैं कि उस क्षेत्र में अधिकतम कितने लोग आ सकते हैं। दुर्घटना का मूल कारण सीमित स्थान में ज़रूरत से ज्यादा लोगों की संख्या का होना है। हमने देखा है कि यदि एक निश्चित स्थान में निश्चित संख्या से लोगों की संख्या कम रहे तो दुर्घटनाएँ नहीं होंगी। हमारा यह प्रदर्श सीमित क्षेत्र (परिसर) में निश्चित संख्या से अधिक लोगों को प्रवेश नहीं देगा जिससे दुर्घटना नहीं होगी।

इस प्रदर्श की मुख्य विशेषताएँ निम्नलिखित हैं-

- (i) प्रवेश द्वार में प्रकाश संवेदी तंत्र लगाकर व्यक्तियों का अवलोकन किया जा सकता है।
- (ii) हम प्रकाश संवेदी गणना तंत्र लगाकर प्रवेश करने वाले व्यक्तियों की संख्या x ज्ञात कर सकते हैं।
- (iii) उपरोक्तनुसार प्रकाश संवेदी गणना तंत्र निकास द्वार पर भी लगाकर बाहर निकलने वाले व्यक्तियों की संख्या y ज्ञात कर सकते हैं।
- (iv) हम प्रवेश द्वार की संख्या x में से निकास द्वार की संख्या y को एक सॉफ्टवेयर द्वारा घटाकर परिसर में उपस्थित व्यक्तियों की संख्या $x - y$ ज्ञात कर सकते हैं।

5. अब परिसर में उपस्थित व्यक्तियों की संख्या $x-y$ (जो पहले से अवलोकन द्वारा तय की जाएगी) से ज्यादा होने पर प्रवेश द्वार में लगा गेट स्वतः बंद हो जाएगा अथवा सिपाही होने की स्थिति में घंटी भी लगाई जा सकती है।

प्रयुक्त सामग्री

थर्मोकोल, फैवीकोल, सैलोटैप, माचिस की तीलियाँ, धागा, कैल्कुलेटर

संरचना एवं कार्यप्रणाली

प्रस्तुत मॉडल में प्रवेश द्वार पर एक कैल्कुलेटर लगा है जिसमें प्रथम कदम रखने पर (-) और दूसरा कदम रखने पर (+) का बटन दबता है जिससे कैल्कुलेटर की स्क्रीन पर गणना होती है और जितने व्यक्ति अंदर जाएंगे उतनी ही संख्या कैल्कुलेटर की स्क्रीन पर दिखाई देगी। यही प्रक्रिया निकास द्वार पर भी होगी (चित्र 16.1)।

प्रवेश द्वार पर बैठा सिपाही निकास द्वार पर बैठा सिपाही से मोबाइल सिस्टम से जुड़ा होगा जो समय-समय पर परिसर में उपस्थित व्यक्तियों की संख्या की जानकारी रखेगा। यदि संख्या से अधिक व्यक्ति परिसर में हों तो प्रवेश द्वार पर बैठा सिपाही व्यक्तियों को अंदर नहीं जाने देगा। हमने इस मॉडल की लागत कम रखने के लिए इस तरह का सिस्टम लगाया है।

इस मॉडल में एक ऐसा सॉफ्टवेयर लगाया गया है जो उस परिसर में व्यक्तियों की संख्या को नियंत्रित रखेगा। इस प्रदर्श में जो सेंसर लगा है वह प्रवेश द्वार पर व्यक्तियों को नियंत्रित करेगा। यदि इस क्षेत्र में अधिकतम 500 व्यक्ति आ सकते हों तो 500 से एक भी व्यक्ति अधिक होने पर यह सेंसर प्रवेश द्वार बंद कर देगा और जैसे ही संख्या 500 से कम होगी यह प्रवेश द्वार खोल देगा जिससे हम भीड़ को नियंत्रित कर पाएँगे। प्रवेश द्वार (x) - निकास द्वार (y) = परिसर के अंदर की संख्या

$$500 - 0 = 500$$

$$700 - 200 = 500$$



चित्र : 16.1

संक्षिप्त विवरण

मॉडल का मुख्य उद्देश्य भीड़भाड़ वाले इलाकों में भगदड़ से मरने वाले निर्दोष व्यक्तियों की जान बचाना है। इसके लिए जगह का अवलोकन कर उसे विभिन्न भागों में बाँटा जा सकता है और छोटे-छोटे क्षेत्रफल में प्रवेश द्वार (प्रवेश द्वार x और निकास द्वार y) द्वारा परिसर में उपस्थित व्यक्तियों की संख्या ज्ञात की जा सकती हैं।

उत्तराखण्ड की दुर्लभ जड़ी-बूटियाँ

छात्र

पवन कुमार काण्डपाल

राजकीय इंटर कालेज

मोतीनगर, नैनीताल

उत्तराखण्ड

अध्यापक

प्रकाश चन्द्र जोशी

प्रस्तावना

जड़ी-बूटियों के क्षेत्र में भारत दुनियाँ को बहुत कुछ दे सकता है। भारत में लगभग 45 हजार पादप प्रजातियाँ हैं जिनमें से अभी तक केवल 2500 पादपों पर ही वैज्ञानिक अनुसंधान कार्य हुए हैं। भले ही इनमें से कई पादपों पर प्रमाणिक वैज्ञानिक अनुसंधान न हुआ हो किंतु इनके औषधीय महत्व का ज्ञान परम्परागत प्रयोगकर्ताओं के पास है, किंतु वे अपने इस ज्ञान को इस कारण सार्वजनिक नहीं करना चाहते कि कहीं सबको जानकारी होने पर इनका सम्मान खत्म न हो जाए अतः उचित जानकारी के अभाव में ये जड़ी-बूटियाँ आज विलुप्त होने की स्थिति में हैं। आज आवश्यकता इस बात की है कि परम्परागत औषधीय ज्ञान को आधार बनाकर इस क्षेत्र में व्यापक अनुसंधान कार्य किए जाएँ। केवल मानव रोगों के इलाज में ही नहीं बल्कि इनके उपयोग अन्य क्षेत्रों में भी संभव हैं। जड़ी-बूटियों की गुणवत्ता बनाए रखने हेतु रासायनिक खाद के स्थान पर जैविक खाद के निर्माण की नवीन तकनीक वायवीय जीवाणु द्वारा अपघटन का मॉडल भी इसमें प्रस्तुत किया गया है।

प्रदर्श निर्माण के पीछे बौद्धिक उद्देश्य

- विलुप्त होती औषधीय पादप प्रजातियों का संरक्षण तथा इनके औषधीय महत्व को जनसामान्य व अनुसंधानकर्ताओं तक पहुँचाना।
- औषधियों के परम्परागत प्रयोगकर्ताओं के ज्ञान को उचित सम्मान दिलाना।

- (iii) औषधीय अनुसंधान को बहु-आयामी बनाने के प्रति दृष्टिकोण विकसित करना।
- (iv) विश्व में (मुख्यतः विकसित राष्ट्रों में) जड़ी-बूटी आधारित चिकित्सा पद्धति के प्रति बढ़ते आकर्षण तथा भारत की स्थिति से परिचित करना।

जैविक कीटनाशक

जड़ी-बूटियों की गुणवत्ता बनाए रखने हेतु इनमें रासायनिक-कीटनाशक के बजाय जैविक-कीटनाशकों का प्रयोग करने हेतु अखरोट के परिपक्व पत्तों / छिलकों से एक जैविक कीटनाशक घोल तैयार किया गया जिसका परीक्षण जड़ी-बूटियों के साथ-साथ कृषि फसलों पर भी किया गया तो आश्चर्यजनक परिणाम प्राप्त हुए। कीट संक्रमित बन्दगोभी की फसल में कई बार रसायनों का छिड़काव करने पर भी कोई लाभ नहीं हुआ जबकि इसी फसल में इस जैविक घोल का छिड़काव करने पर पूरे समय तक फसल कीटों के प्रकोप से मुक्त रही।

सिद्धांत

किसी भी जैविक कीटनाशक के पीछे निम्न सिद्धांत काम करता है -
 “कुछ पादप प्रजातियों में जब कीटों का प्रकोप होता है तो इन कीटों से अपनी रक्षा हेतु इन पादपों में कुछ विशेष रसायनों का निर्माण होने लगता है। इन रसायनों के प्रभाव से हानिकारक कीट व उनका लारवा समाप्त हो जाते हैं”।

विधि

अखरोट के परिपक्व पत्तों / अखरोट के छिलकों को कूटकर इन्हें किसी पात्र में उबालकर इनका सान्द्र घोल प्राप्त कर लेते हैं। प्राप्त घोल को ठण्डा करके उसे पानी में मिलाकर संक्रमित फसल में छिड़काव करने से कीट तुरन्त मर जाते हैं। दस दिन के बाद दूसरा छिड़काव करने पर उनका लारवा भी पूर्णतः नष्ट हो जाता है।

लाभ

यह अत्यन्त प्रभावशाली इको-फ्रेण्डली कीटनाशक है। इसका प्रयोग भंडारित अनाज की कीटों से रक्षा हेतु भी किया जा सकता है। इसका कोई विपरीत प्रभाव भी नहीं है।

समस्या की पृष्ठभूमि

जैविक खाद निर्माण की परम्परागत विधि में जैव अपशिष्ट को एक वायुरोधी गड्ढे में डाला जाता है जहाँ अवायवीय जीवाणु इस जैव अवशिष्ट का अपघटन करके उसे जैविक

खाद में बदल देते हैं। इस विधि से जैविक खाद निर्माण में काफी अधिक समय (लगभग 4-5 माह) लगता है तथा जैव अपशिष्ट का पूर्णतः अपघटन भी नहीं हो पाता। फलतः प्राप्त जैविक खाद की गुणवत्ता निम्न स्तर की रहती है।

परंपरागत विधि की इन दोनों कमियों को दूर करने हेतु जैविक खाद निर्माण की एक नवीन विधि का मॉडल तैयार किया गया है जिसमें अपघटन का कार्य अवायवीय जीवाणुओं के बजाए वायवीय जीवाणुओं द्वारा किया जाता है। इस विधि में बहुत कम समय (लगभग 30 दिन) में ही जैविक खाद तैयार हो जाती है तथा जैव अपशिष्ट का पूर्ण अपघटन भी हो जाता है फलस्वरूप उच्च गुणवत्तायुक्त जैविक खाद प्राप्त होती है।

सिद्धांत

“उचित ताप व नमी की उपस्थिति में कुछ जीवाणु ऑक्सीजन की उपस्थिति में जटिल कार्बनिक पदार्थों को सरल पदार्थों में अपघटित कर देते हैं।”

विधि

बाँस के डण्डों को जमीन में गाड़कर उनकी सहायता से किसी खुले स्थान पर (जहाँ दिन भर धूप रहती हो) एक घनाभ आकार प्लास्टिक के कक्ष का निर्माण करते हैं। इसमें हरी घास, गोबर, सूखे पत्ते आदि की परतें बिछाकर कमरे को प्लास्टिक शीट से बंद कर देते हैं। उक्त जैव अपशिष्ट की विभिन्न परतों के बीच मिट्टी की पतली परतें भी बिछाते जाते हैं। कमरे में ऑक्सीजन की सप्लाई बनाए रखने के लिए बाँस से उर्ध्वाधर एवं क्षैतिज पाइप कमरे के अंदर प्रवेश करा दिए जाते हैं। यद्यपि कमरे में हरा चारा नमी बनाए रखता है फिर भी यदि नमी की कमी हो तो बाहर से थोड़ा जल कमरे में पहुँचा दिया जाता है। चैम्बर में प्रयुक्त प्लास्टिक पन्नी ग्रीन हाउस का काम करती है जिससे कमरे के अंदर उचित ताप (25-30 से. ग्रे.) बना रहता है। इस ताप पर वायवीय जीवाणु अत्यधिक क्रियाशील होकर तेजी से अपघटन करते हैं और जीवाणुओं की संख्या में भी तेजी से वृद्धि होती है जिससे अल्प समय में ही जैव अपशिष्ट पूर्णतः अपघटित हो जाता है।



चित्र : 17.1



चित्र : 17.2



चित्र : 17.3



चित्र : 17.4

कोयला खनन क्षेत्रों की भूमिगत आग से विद्युत ऊर्जा

छात्र

हेमलता भारती
आराधना कुमारी

के.बी. बालिका उच्च विद्यालय
रातू पथ, राँची
झारखण्ड

अध्यापिका

सुरेश कुमार सिन्हा

प्रस्तावना

वर्षों से भारत के झारखण्ड क्षेत्र एवं विश्व के अन्य देशों के कोयला खनन क्षेत्रों में भूमिगत कोयले में आग लगी हुई है जिससे कोयले की ऊष्मीय ऊर्जा का बिना किसी उपयोग के लगातार क्षय हो रहा है। बहुत प्रयास के बाद भी इस पर काबू नहीं पाया जा सका है। इस ऊर्जा को बेकार होने देने से अच्छा है कि इसका उपयोग विद्युत ऊर्जा के उत्पादन एवं अन्य कार्यों में किया जाए।

सिद्धांत

कोयला क्षेत्र की भूमिगत आग में पाइप द्वारा जल भेजते हैं जो बॉयलर जैसा कार्य करता है। कोयले की ऊष्मा से जल भाप में बदल जाता है। इस भाप से विद्युत जनित्र के टरबाइन को घुमाकर विद्युत ऊर्जा प्राप्त हो सकती है।

शुष्क-वाष्प शक्ति संयंत्र

इस विधि में भूमिगत कोयले की ऊष्मा से पाइप में भरे पानी को गरम किया जाता है फिर इससे प्राप्त भाप से जनित्र के टरबाइन को घुमाया जाता है जिससे विद्युत ऊर्जा प्राप्त होती है। पुनः भाप को संघनित कर जल के रूप में इसे पुनः पाइप में डाला जाता है। यह विधि अधिक ताप पर बेहतर कार्य करती है।

द्विकर्मी शक्ति संयंत्र

इस विधि में भूमिगत कोयले की ऊष्मा से पानी को गर्म किया जाता है और कम व्वथनांक वाले कार्बनिक द्रव आइसोपेन्टेन को गरम जल या भाप से गरम किया जाता है। इस प्रकार कार्बनिक द्रव के वाष्प से जनित्र के टरबाइन को घुमाया जाता है जिससे विद्युत ऊर्जा प्राप्त होती है। पुनः कार्बनिक द्रव को वाष्प संघनित कर वाष्प कक्ष में भेजा जाता है।

आवश्यक उपकरण

लकड़ी का स्टैण्ड जिसपर टरबाइन घुम सके, प्लास्टिक की घिरनी, धातु का पाईप, साईकिल में लगने वाला जनित्र, तार, एल.ई.डी. या टॉर्च के बल्ब, कुकर, गैस स्टोव, कागज का गत्ता, रबर के पाईप, छोटे-छोटे डिब्बे, मोटे पाईप के टुकड़े, रंग आदि।

संरचना

गैस स्टोव पर कुकर में पानी को गर्म करते हैं। जलता गैस स्टोव भूमिगत कोयले की ऊष्मा का प्रतीक है तथा कुकर बॉयलर जैसा कार्य करता है। रबर की नली की सहायता से भाप द्वारा लकड़ी के स्टैण्ड पर रखी घिरनी को घुमाया जाता है जो शैफ्ट द्वारा जनित्र से जुड़ी रहती है। एक बल्ब (एल.ई.डी.) तार की सहायता से जनित्र से जुड़ा रहता है।

कार्य पद्धति

गैस की भाप रबर के पाईप से टरबाइन के ब्लेडों पर डाली जाती है जिससे टरबाइन घूमती है और इसमें गतिज ऊर्जा आ जाती है। टरबाइन की घूर्णन गति के कारण इसमें लगा शैफ्ट भी घुमने लगता है एवं शैफ्ट से जुड़ा हुआ आर्मेचर भी जनित्र के चुम्बकीय घुवों के बीच घुर्णन करने लगता है। विद्युत चुम्बकीय प्रेरण के कारण जनित्र में धारा प्रेरित होती है जिसके कारण जनित्र से लगा विद्युत बल्ब (एल.ई.डी.) जल उठता है। प्रेरित धारा की दिशा फ्लेमिंग के दक्षिण हस्त-नियम द्वारा निर्धारित होती है।

भाप को संघनित कर पुनः बॉयलर में भेजा जाता है।

महत्वपूर्ण बातें

- (i) इस मॉडल में बेकार हो रहे भूमिगत कोयले की ऊष्मा का उपयोग होता है।
- (ii) कम लागत पर विद्युत ऊर्जा प्राप्त होती है।
- (iii) भूमिगत कोयले की आग बढ़ने की दर को कम करता है।
- (iv) द्विकर्मी शक्ति संयंत्र का उपयोग गरम झरनों से विद्युत ऊर्जा प्राप्त करने में किया जा सकता है।

निर्देशन

प्रदर्शित मॉडल में एन.सी.ई.आर.टी. एवं खनन इंजीनियरी की पुस्तकों, इंटरनेट से सहायता एवं शिक्षक से विशेष मार्गदर्शन प्राप्त हुआ है।

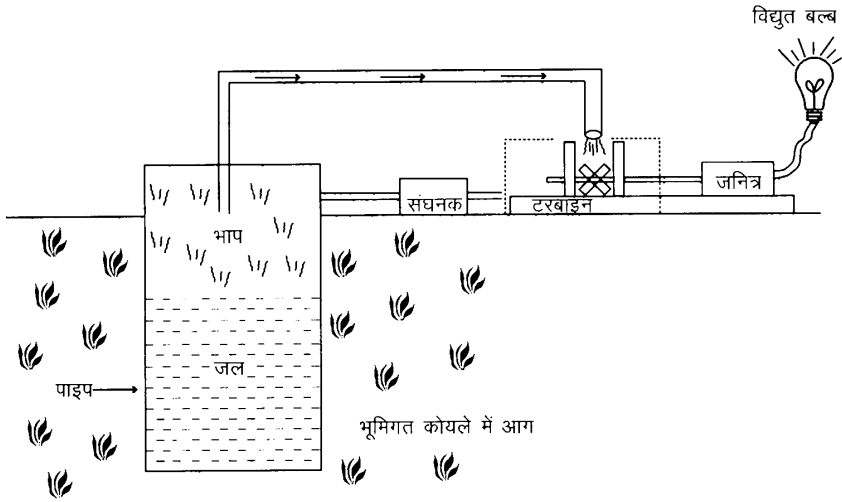

चित्र : 18.1

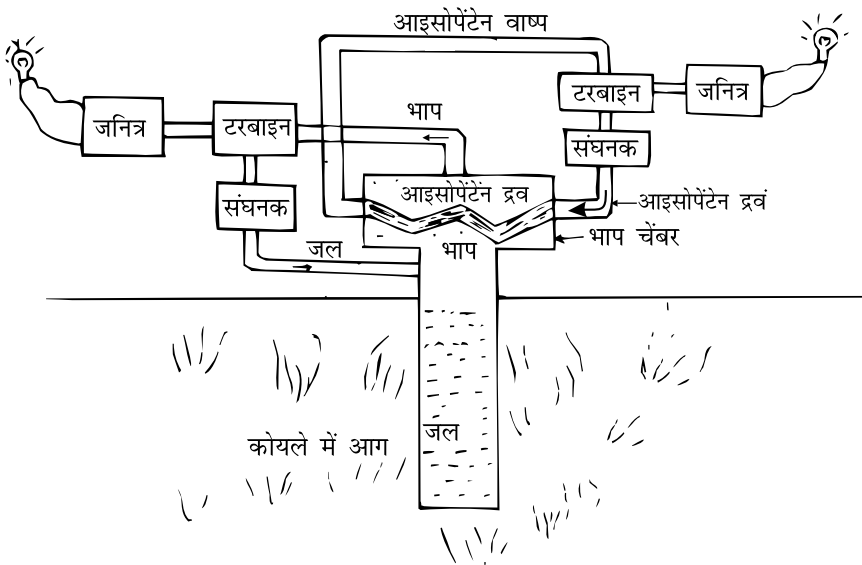

चित्र : 18.2

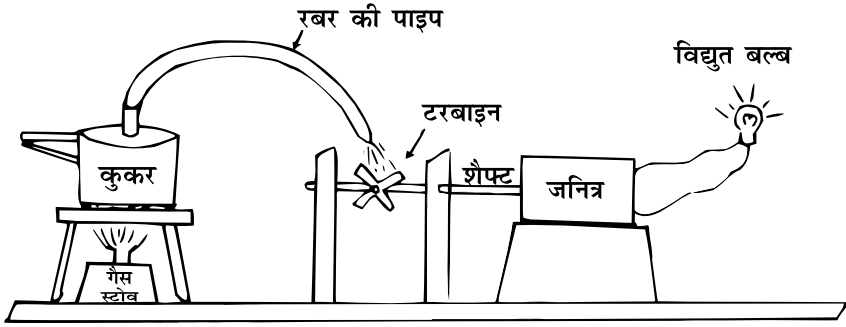

लकड़ी का स्टैंड

ऊर्जा का रूपांतरण

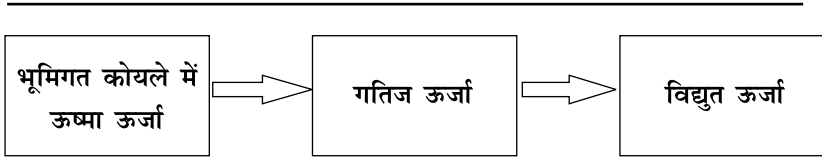

चित्र : 18.3

बहुउद्देशीय वाहन अनलॉडिंग सिस्टम

छात्र

आशीष जोशी

बुनियादी उच्चतर माध्यमिक विद्यालय
गांधी विद्या मंदिर, सरदारशहर
राजस्थान

अध्यापक

बजरंगलाल सोनी

प्रस्तावना

प्रचलित समय में सामान ढोने वाले वाहन से हाइड्रोलिक प्रणाली द्वारा सामान उतारा जाता है, परंतु उनमें एक विशेष कमी यह रहती है कि इन वाहनों में ऐसी व्यवस्था होती है कि इनमें रखा सामान केवल एक ही तरफ उतर सकता है वो भी केवल पीछे की तरफ। मान लीजिए कि एक संकरी गली में दाईं अथवा बाईं ओर सामान उतारना है तो प्रचलित वाहनों के द्वारा हम केवल पीछे की ओर ही सामान उतार सकते हैं, दाईं अथवा बाईं ओर सामान उतारने की कोई व्यवस्था नहीं होती है। संकरी गली होने के कारण वाहन को दाएँ अथवा बाएँ घुमाकर आगे अथवा पीछे की ओर भी नहीं किया जा सकता। इन वाहनों में इस प्रकार की कमी को देखते हुए एक बहुउद्देशीय उपकरण का निर्माण इस मॉडल के रूप में किया गया है।

समविष्ट सिद्धांत

इस प्रदर्श में निम्नलिखित सिद्धांतों का उपयोग किया गया है-

- (i) सरल उत्तोलक का सिद्धांत;
- (ii) विद्युतीय चुम्बक द्वारा प्रभावी घूर्णन बल उत्पन्न करने का सिद्धांत;
- (iii) द्रव के दाब के नियमों पर आधारित हाइड्रोलिक सिद्धांत।

प्रयुक्त सामग्री

लोहे की छड़ें, सिरिंज, द्रव, पिस्टन, विद्युत चुम्बक, विद्युत मोटर, गीयर बॉक्स, एल्युमिनीयम प्लाई, लकड़ी, नट-बोल्ट, रंग रोगन आदि।

संरचना व कार्यप्रणाली

प्रयुक्त प्रयोग में तीन प्रकार के ट्रकों का मॉडल बनाकर उनमें तीन विधियों का उपयोग करते हुए वाहन अनलोडिंग व्यवस्था को दर्शाया गया है:

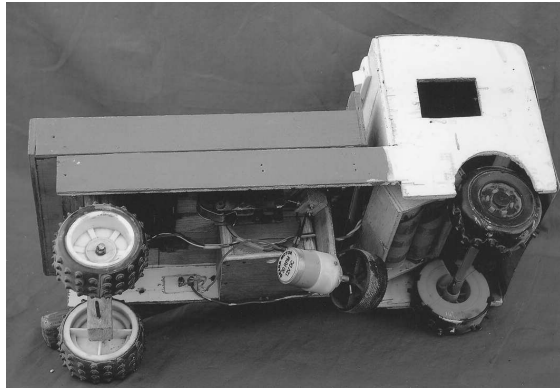

चित्र : 19.1

- (i) साधारण लीवर द्वारा उत्तोलकों के आधार पर बनी घुमावदार छड़ों से बल प्रयोग करते हुए ट्रक के पीछे के पलड़े को ऊपर, नीचे, दाएँ, बाएँ पलटने का प्रयास किया गया है।



चित्र : 19.2

- (ii) द्वितीय ट्रक के मॉडल में काम में लाई गई खराब सीरीज ट्यूब व पिस्टन का इस्तेमाल करते हुए हाइड्रोलिक सिस्टम द्वारा बल उत्पन्न कर प्रथम ट्रक की संरचना की तरह ही हाथ के सीधे बल का सीधे उपयोग न करते हुए हाइड्रोलिक बल के उपयोग से सामान को तीनों तरफ अनलोडिंग करने की व्यवस्था दिखाई गई है।

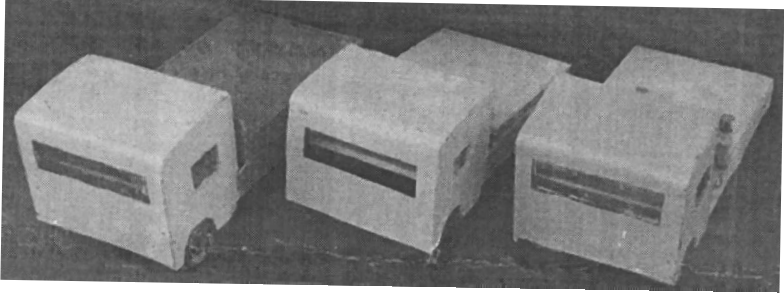

चित्र : 19.3

- (iii) तीसरे ट्रक में विद्युत ऊर्जा की सहायता से विद्युत मोटर का संचालन करते हुए गीयर बॉक्स से उसी प्रकार से बल लगाया गया है जिस प्रकार प्रथम एवं द्वितीय ट्रक में हाथ व हाइड्रोलिक बल के द्वारा किया गया है। इस प्रकार इस ट्रक में अनलोडिंग सिस्टम हाथ के बल तथा हाइड्रोलिक बल से न होकर विद्युत ऊर्जा द्वारा किया गया है।

उपयोग

- (i) ट्रक के तीनों ओर से सामान अनलोडिंग होने से किसी भी प्रकार के मार्ग में इच्छित स्थान पर तुरंत ही सामान को उतारा जा सकता है।
- (ii) इस क्रिया में परिश्रम तथा समय की बचत के साथ ईंधन की बचत होती है।
- (iii) छात्र उत्तोलक, हाइड्रोलिक एवं विद्युतीय नियमों की व्यावहारिक जानकारी प्राप्त करते हैं।

स्वदेशी कीटनाशक स्प्रेयर एवं खरपतवार नियंत्रक यंत्र

छात्र

राकेश कुमार सेन

राजकीय उच्चतर माध्यमिक विद्यालय
प्रतापगढ़, राजस्थान

अध्यापक

अनिल कुमार वप्ता

प्रस्तावना

हमारे देश में कृषि का प्रथम स्थान है। कृषि के बिना उद्योग तथा मानव जीवन संभव नहीं है। भारत की 70 प्रतिशत जनसंख्या कृषि पर निर्भर है। कृषि में उन्नत तरीके लाना आवश्यक है जिससे अधिक लाभ प्राप्त हो तथा देश के किसानों की स्थिति में सुधार हो। वर्तमान में फसलों को कीटों, इल्लियों, फफूंद द्वारा हानि होती है। इसके नियंत्रण के लिए किसान कीटनाशक रसायनों का छिड़काव करते हैं। हाथों द्वारा चालित स्प्रेयर द्वारा बनने वाली गैस से मनुष्य को नुकसान की संभावना रहती है। इस प्रादर्श में हमने स्वदेशी तकनीक पर आधारित ट्रैक्टर द्वारा चालित छिड़काव यंत्र तैयार किया है। इस यंत्र से कम खर्च तथा कम शारीरिक बल द्वारा अधिक क्षेत्र में कम समय में रसायनों का छिड़काव किया जा सकता है। इस पूरे कार्य को अकेला व्यक्ति कर सकता है।

उद्देश्य

- इस तकनीक से कम लागत तथा कम समय में समान रूप से अधिक छिड़काव किया जा सकेगा तथा शारीरिक बल भी कम लगेगा।
- रसायन छिड़कने वाले को बिना कोई हानि हुए हानिकारक कीटों से फसल को सुरक्षित रखा जा सकेगा।

समाविष्ट वैज्ञानिक सिद्धांत

यह यंत्र पॉस्कल के दाब के सिद्धांत पर कार्य करता है।

प्रदर्श निर्माण में प्रयुक्त सामग्री

एक पंजे के समान स्टैंड, प्लास्टिक का 500 L लीटर का ड्रम, तीन लोहे की नलियाँ, 15 फव्वारे, खिलौना ट्रैक्टर, तीन प्लास्टिक की नलियाँ, छलनी, पम्पा।

संरचना एवं कार्यप्रणाली

प्रथम भाग - कीटनाशक स्प्रेयर

लोहे के एक पंजे के समान स्टैंड के पीछे तीन लोहे की नलियाँ लगाई गई हैं। इन नलियों में छेद करके (प्रत्येक नली में पाँच छेद) 15 फव्वारे (5 \times 3=15) लगाए गए हैं। स्टैंड पर 500 लीटर का प्लास्टिक का ड्रम रखा जाता है जिसमें कीटनाशक रसायन भरा जाता है।

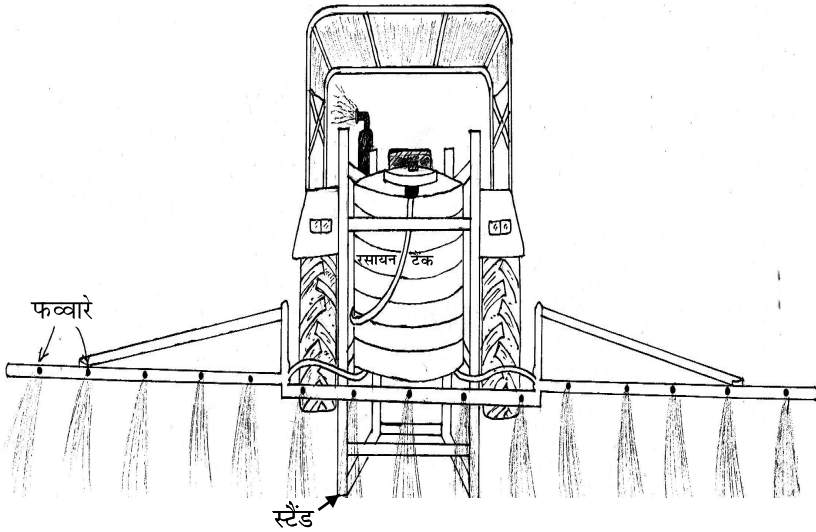

चित्र 20.1



चित्र 20.2

ड्रम को एक सहायक नली से जोड़कर पम्प से जोड़ते हैं। ट्रैक्टर के चलने से उसमें लगी शॉफ्ट घूमने लगती है जिससे फव्वारे चलने लगते हैं। स्टैंड भूमि से 3-4 फीट ऊपर उठा होता है। आगे दोनों पहियों पर त्रिभुज समान चदर लगाई गई है जो ट्रैक्टर के चलते समय फसलों को अलग करती जाती है जिससे फसल को नुकसान नहीं होता है। इस विधि से फसलों को हानिकारक कीटों से जल्दी ही बचाया जा सकता है। कम समय में न्यून शारीरिक बल द्वारा अधिक क्षेत्र में रसायन का समान मात्रा में छिड़काव किया जा सकता है।

द्वितीय भाग - खरपतवार नियंत्रण यंत्र

इस यंत्र को हमने स्वदेश तकनीक पर तैयार किया है जो इंजन द्वारा चालित है। इसमें खरपतवार नियंत्रण होता है। इसमें पीछे की तरफ 8-10 खुरपे लगे होते हैं जिससे जल्दी तथा कम समय में अधिक क्षेत्र में लगे हुए खरपतवार तथा हानिकारक कीटों के अण्डे लारवा बाहर निकल आते हैं। तेज धूप के प्रभाव से खरपतवार व हानिकारक कीटों के अण्डे नष्ट हो जाते हैं। इस यंत्र से पर्यावरण भी प्रदूषित नहीं होता है क्योंकि यह एल.पी.जी.गैस द्वारा चालित है। एक किलो गैस से यह यंत्र 5-7 बीघा क्षेत्र में चलता है। इस यंत्र द्वारा कम खर्च में अधिक क्षेत्र का खरपतवार नियंत्रण किया जा सकता है। बैलों द्वारा कम क्षेत्र (2 बीघा) में ही खरपतवार नियंत्रण किया जा सकता है। इस यंत्र का उपयोग गरीब किसान भी कर सकते हैं।

जल द्वारा चालित कार

छात्र

गोविन्द भोजक

बुनियादी उच्चतर माध्यमिक विद्यालय

गाँधी विद्या मंदिर

सरदारशहर

राजस्थान

अध्यापक

बजरंगलाल सोनी

उद्देश्य

यातायात के प्रमुख साधन पेट्रोल, डीजल, गैस द्वारा चालित वाहन हैं। प्राकृतिक ऊर्जा की खपत से पर्यावरणीय प्रदूषण होता है तथा निकट भविष्य में इनकी समाप्ति भी निश्चित है। इन परिस्थितियों में यह आवश्यक है कि पर्यावरण अनुकूल तथा वैकल्पिक ऊर्जा स्रोत से चालित वाहनों का विकास किया जाए। वाहनों को जल, वायु, समुद्री जल आदि ऊर्जा से सामान्य तकनीक से चला पाना सम्भव नहीं है, परन्तु इन सभी अपरम्परागत ऊर्जाओं का रूपान्तरण विद्युत ऊर्जा अथवा रासायनिक ऊर्जा में करके वाहनों को चलाया जा सकता है। जैसे, वायु ऊर्जा से विद्युत उत्पन्न कर, इस विद्युत को संचालक सैलों में एकत्रित कर वाहनों में इनका उपयोग किया जा सकता है। इसी प्रकार सौर ऊर्जा से विद्युत प्राप्त कर, विद्युत को अन्य ऊर्जाओं में रूपान्तरित कर वाहनों में उपयोग में लाया जा सकता है। इन्हीं तथ्यों को ध्यान में रखते हुए प्रदर्श का निर्माण किया गया है।

प्रस्तुत प्रदर्श हाइड्रोजन गैस से चालित फ्यूल सैल से उत्पन्न विद्युत ऊर्जा का उपयोग करते हुए बनाया गया है। इसमें सौर ऊर्जा से प्राप्त विद्युत ऊर्जा का अधिकतम उपयोग किस प्रकार किया जाता है यह भी दर्शाया गया है। सौर ऊर्जा से चलने वाले वाहनों में आने वाली सामान्य बाधाओं का निराकरण भी इस प्रदर्श में किया गया है। बादलों का आच्छादित होना अथवा रात का अंधेरा इस वाहन की प्रक्रिया में बाधा नहीं डाल पाता।

इस वाहन के निर्माण में सौर ऊर्जा के लिए प्रकाशीय फोटो सैल का उपयोग किया गया है परंतु इस प्रक्रिया में नवाचार का प्रयोग करते हुए फ्यूल सैल को भी समाविष्ट किया गया है।

सिद्धांत

- (i) प्रकाशीय विद्युत प्रभाव द्वारा सौर ऊर्जा का विद्युत ऊर्जा में रूपांतरण।
- (ii) विद्युत द्वारा जल अपघटन क्रिया से हाइड्रोजन एवं आक्सीजन प्राप्त करना।
- (iii) रासायनिक प्रभावों व क्रियाओं द्वारा जल के विद्युत अपघटन से प्राप्त हाइड्रोजन व आक्सीजन के उपयोग से विद्युत प्राप्त करना।
- (iv) विद्युत चुम्बकीय सिद्धांतों के द्वारा विद्युत मोटर का संचालन।
- (v) लीवर एवं उत्तोलक क्रिया द्वारा गीयर बॉक्स का संचालन कर गति प्राप्त करना।
- (vi) फ्यूल सैल की सामान्य अभिक्रियाएँ व उपयोग।
- (vii) सामान्य विद्युतीय परिपथ से संबंधित वोल्ट, एम्पीयर आदि के सिद्धांतों का विस्तार।

प्रयुक्त सामग्री

- (i) प्लास्टिक, प्लाई व अन्य साधन सामग्री से निर्मित कार का मॉडल।
- (ii) सोलर पैनल।
- (iii) जल विद्युत विश्लेषण उपकरण का निर्माण प्लास्टिक शीट द्वारा।
- (iv) कार्बन, प्लास्टिक, फार्मेल्लिडहाइड व जल तथा रबड़ नलिकाओं द्वारा 5 फ्यूल सैल ईकाईयों का निर्माण।
- (v) संबंध कारक तार, लीवर, पहिए, नट-बोल्ट, मीटर, स्विच, मोटर व गीयर बॉक्स आदि।

संरचना एवं कार्यप्रणाली

प्रस्तुत मॉडल के निर्माण में सर्वप्रथम कार का मॉडल तैयार किया गया जिसका संचालन पहियों के साथ जुड़े हुए गीयर बॉक्स से होता है। गीयर बॉक्स में गति विद्युत मोटर द्वारा प्राप्त होती है। यह विद्युत ऊर्जा फ्यूल सैल से प्राप्त होती है। कार्बन, रासायनिक पदार्थ, प्लास्टिक आदि से फ्यूल सैल का निर्माण किया गया है। फ्यूल सैल के फ्यूल के रूप में आक्सीजन व हाइड्रोजन, जल के विद्युत अपघटन द्वारा प्राप्त होते हैं, इस जल अपघटन की क्रिया के लिए आवश्यक ऊर्जा सोलर पैनल से मिलती है, जबकि सोलर पैनल को प्रकाश ऊर्जा सूर्य से मिलती है, इस प्रकार यह क्रिया निम्नानुसार पूरी होती है।

हाइड्रोजन ईंधन कोष्ठिका

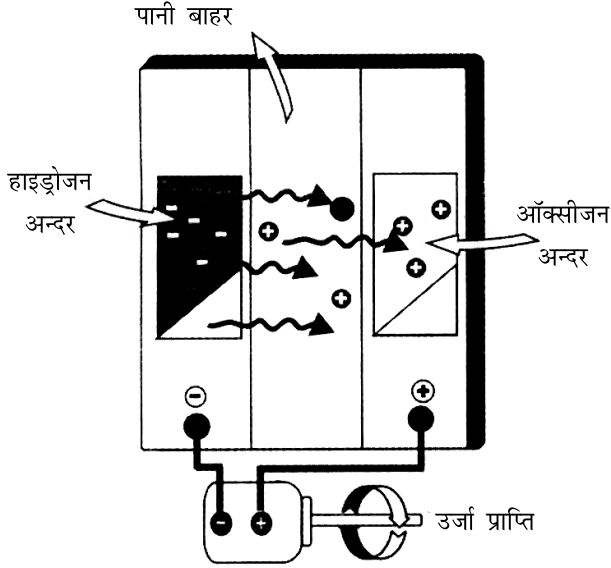

चित्र : 21.1

समीकरण

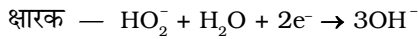
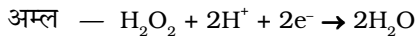
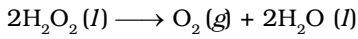
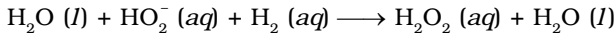
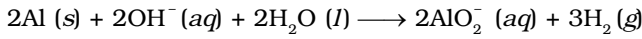
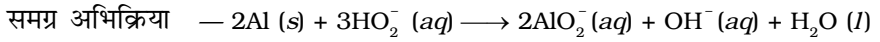
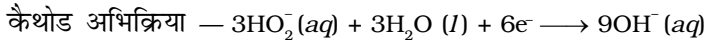
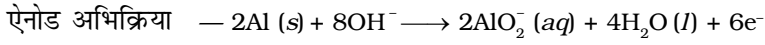

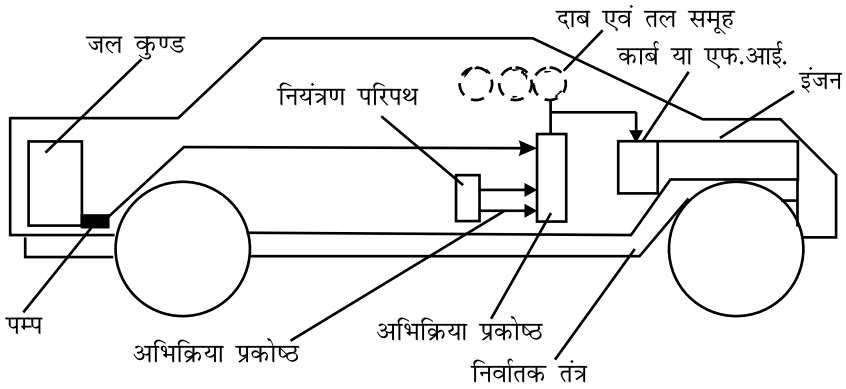

चित्र : 21.2

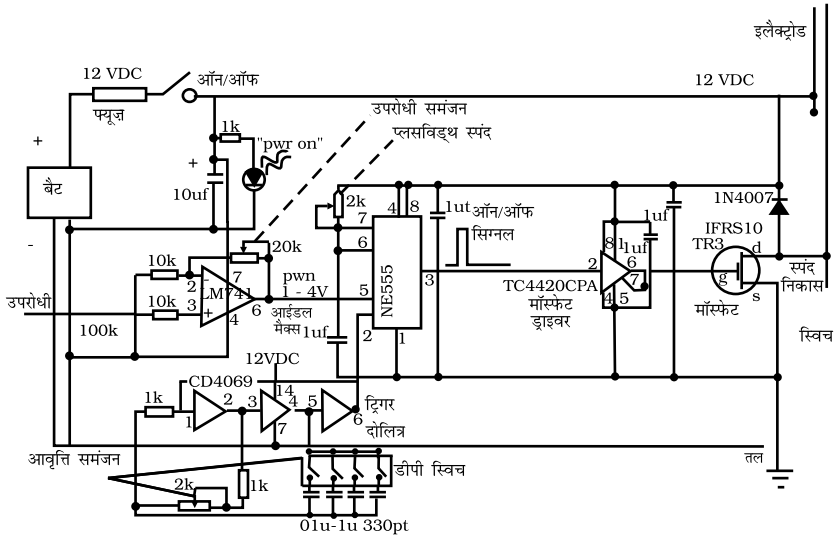

चित्र : 21.3

जब सूर्य का प्रकाश सोलर पैनल पर पड़ता है तो आइन्सटाइन के प्रकाश-विद्युतीय प्रभाव के आधार पर विद्युत प्राप्त होती है। इस विद्युत धारा को पानी के टैंक में व्यवस्थित दो इलेक्ट्रोडों पर भेजा जाता है। जिससे पानी का विद्युत अपघटन होता है तथा अलग-अलग

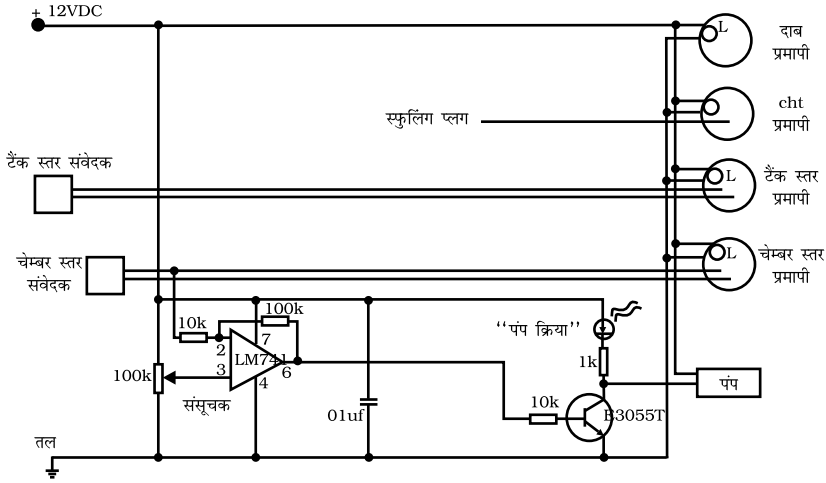

चित्र : 21.4

पाइपों में हाइड्रोजन व आक्सीजन गैसों प्राप्त होती हैं। ये दोनों गैसों दो चेम्बरों में संग्रहित होती रहती हैं जब वाहन चलती हुई अवस्था में नहीं होता है तो यह क्रिया चालू रहती है जिससे आक्सीजन तथा हाइड्रोजन, स्टॉक टैंक में जमा होती रहती हैं। ये जमा गैसों बादल आच्छादित होने पर अथवा रात में वाहन चलाने के काम आती हैं। ऑक्सीजन तथा हाइड्रोजन गैसों इस वाहन में बने फ्यूल सैल के कार्बन इलैक्ट्रोडों पर जमा होती हैं तथा फ्यूल सैल की कार्यप्रणाली के अनुसार विद्युत ऊर्जा का निर्माण करती हैं क्योंकि फ्यूल सैल से विद्युत् प्राप्ति के लिए हाइड्रोजन गैस ईंधन के रूप में काम आती है। इस प्रकार फ्यूल सैल से प्राप्त विद्युत को विद्युत मोटर में भेजा जाता है। इस मोटर का विद्युतीय परिपथ पूर्ण होने पर एक्सल में घूर्णन गति प्राप्त होती है जिसे पहियों से संबंधित गीयर बॉक्स की सहायता से कम अथवा अधिक किया जाता है। इस प्रकार हाइड्रोजन द्वारा चलित जल कार कार्य करती है।

उपयोग

- (i) पर्यावरणीय प्रदूषण से मुक्त वाहन।
- (ii) सह उत्पादन में पानी का निर्माण।
- (iii) सोलर पेनल से प्राप्त ऊर्जा का उपयोग फ्यूल सैल में होने से वाहन संचालन में सीधे सूर्य के प्रकाश की आवश्यकता नहीं रहती है। अतः इसका संचालन इसी विधि से रात के समय में क्रिया कर सकता है।
- (iv) आर्थिक दृष्टिकोण से यह कार कम व्यय पर अधिक माइलेज देती है।



विद्यया ऽ मृतमश्नुते



एन सी ई आर टी
NCERT

राष्ट्रीय शैक्षिक अनुसंधान और प्रशिक्षण परिषद्
NATIONAL COUNCIL OF EDUCATIONAL RESEARCH AND TRAINING